

DOCUMENT 00 91 13.1  
ADDENDUM NO. 1

May 22, 2026

RE: Wellington City – Administration and Emergency Services Building  
Project No. 2509-014

FROM: Jones & DeMille Engineering, Inc. & Campbell Architecture  
1675 South Highway 10  
Price, UT 84501

TO: Prospective Bidders

This addendum forms a part of the Contract Documents and modifies the original Procurement Documents, dated May 13, 2026, as noted below. Acknowledge receipt of this Addendum in the space provided on the Bid Form. Failure to do so may subject the Bidder to disqualification.

This Addendum consists of 2 pages and 27 attachments.

CHANGES TO PROCUREMENT REQUIREMENTS:

1. Document 00 11 13 – Advertisement for Bids, updated that bids can be received electronically.
2. Document 01 20 00 – Price and Payment Procedures, added section 1.6 for allowances for an electronic marquee and AV programming.
3. Document 00 41 11 – Bid Form For Construction Contract, added section 3.01.B for AV programming and Electronic Marquee Allowances.
4. Document 00 45 13 – Bidder's Qualifications, updated the number and type of required projects on the form.

CHANGES TO SPECIFICATIONS:

5. Section 05 31 23 – Steel Roof Decking, spec section added.
6. Section 06 41 16 – Plastic Laminate Cabinets, modifications to section 2.1.
7. Section 08 23 21 – Four Fold Door System, addition of Just Doors to approved Manufacturers.
8. Section 08 71 00 – Door Hardware, spec section added.
9. Section 08 88 53 – Bullet Resistant Glazing- Polycarbonate, spec section added.
10. Section 09 93 00 – Staining and Transparent Finishing, spec section added.

CHANGES TO DRAWINGS:

11. S-103 – Foundation Plan – Fire Department, updated concrete foundation wall.
12. S-501 – Structural Details, added gridline locations to some details.
13. S-502 – Structural Details, added note to see architect for truss dimensions.
14. S-601 – Structural Schedules, added wall to concrete wall schedule.
15. AD -101 – Demolition Plan, demo notes clarified.
16. A-101 – Dimension Plan – Overall Floor Plan, dimension notes updated.
17. A-102 – Dimension Plan – City Offices & Police Department, dimension added and dimension notes updated.
18. A-103 – Dimension Plan – Fire Department, dimension added and dimension notes updated, fire wall detail added.
19. A-104 – Dimension Plan – Apparatus Bay, dimension added and dimension notes updated.
20. A-105 – Floor Plan – Overall, bollard Detail location called out.
21. A-112 – Roof Plan Overall, removal of Mechanical Curb detail.
22. A-301 – Building Sections, truss heel heights added as well as callout for mechanical chase in truss.
23. A-302 – Building Sections, grid line corrected in detail 7, heel height called out in Section 2.
24. A-311 – Wall Sections/Details, truss appearance and location of grid adjusted, width of expansion joint called dimensioned.
25. A-313 – Wall Sections/Details, column Detail outside of fire department added.
26. A-407 – Enlarged Floor Plans & Elevations, update to apron detail on counter section.
27. A-501 – Storefront Window Details, update to sill detail on Storefront SF-15.

Signed: **Wyatt Hansen, Project Engineer**

END OF ADDENDUM



05/22/2026

**DOCUMENT 00 11 13**  
**ADVERTISEMENT FOR BIDS**

**WELLINGTON CITY, 150 WEST MAIN STREET, WELLINGTON, UTAH 84542**

**General Notice:**

**Wellington City** (Owner) is requesting Bids for the construction of the following Project: **Wellington City Administration and Public Safety Building**.

Bids for the construction of the Project will be received at Jones & DeMille Engineering located at 1675 South Highway 10 Price, Utah 84501, until **Wednesday, June 10, 2026 at 3:00 pm** local time. At that time, the Bids received will be publicly opened and read.

Bids for the construction of the Project may also be received electronically at [recorder@wellingtonutah.gov](mailto:recorder@wellingtonutah.gov) with a courtesy copy (cc) to [wyatt.h@jonesanddemille.com](mailto:wyatt.h@jonesanddemille.com), [mayorclark@wellingtonutah.gov](mailto:mayorclark@wellingtonutah.gov) and [trasie.m@jonesanddemille.com](mailto:trasie.m@jonesanddemille.com) until **Wednesday, June 10, 2026 at 3:00 pm** local time.

The Project includes the following Work: Wellington City is seeking sealed lump sum bids for construction of Wellington City Administration and Public Safety Building. Project consists of approximately 18,450 SF of new construction and remodel work across three interconnected structures. Project is designed per 2021 IBC under mixed occupancy classification of A-3, B, and S-1, fully sprinklered per IBC Construction Type VB.

New City Office and Police Department (approximately 7,600 SF): This new single-story wood-framed building houses City Administration offices, City Council Chambers, and a Police Department. City Council Room features tall ceilings with moveable partitions for multi-use occupancy, elevated council chambers, and custom millwork. Police Department includes secure evidence storage, interview rooms, reception, and a dedicated break room. Exterior facade incorporates natural stone sourced from local Wellington supplier.

New PEMB Fire Apparatus Bay (approximately 3,950 SF): New Pre-Engineered Metal Building (PEMB) apparatus bay is configured as a pull-through design to accommodate ladder truck and additional firefighting vehicles. The PEMB is to be procured and installed by General Contractor under this contract. JDE will provide foundation design based on reactions supplied by PEMB manufacturer following contractor procurement.

Existing Fire Station Remodel (approximately 6,900 SF): Existing fire station will receive comprehensive remodel including fire bays, Fire Chief's office, training rooms, decontamination and bunker gear areas, laundry facilities, and open office space. Existing open web steel joists remain in place and will receive new metal roof deck and membrane roofing system. Most HVAC equipment is rooftop mounted. A fire riser room with full fire sprinkler system is included. Fire station must remain fully operational throughout construction. Contractor will be required to coordinate a detailed construction schedule with Owner so fire department can manage and relocate equipment within facility during active remodel phases.

Site Work and Civil: Site work includes concrete sidewalks, curb and gutter, pedestrian ramps, HMA paving, pavement marking, landscaping, irrigation, and signage. A digital marquee sign is included in site scope. All utilities are at or near site and early coordination with utility providers is strongly encouraged. Wellington City will furnish material for temporary chain link security fence around project site for

duration of construction. Contractor is responsible for fence maintenance and providing any additional temporary fencing required for site security or safety.

Telecommunications and Low Voltage: Drawings include a low voltage and telecommunications scope to be supplied and installed by contractor. This includes structured cabling and data networks, audiovisual systems, security cameras, door access control with card readers, and associated equipment and material. Dedicated drawing sets are included for audiovisual (TA sheets), structured cabling and data (TN sheets), and security systems (TY sheets).

Site Preparation and Owner Furnished Items: Demolition of existing city building, including all asbestos abatement, has been completed by Wellington City and Carbon County prior to this contract. The Carbon County Road Department has supplied and placed structural fill to existing grade per the geotechnical engineer's recommendations, with density testing completed by JDE confirming 95% compaction or better. If additional structural fill, untreated base course, or road base is needed during construction, Carbon County Road Department will deliver material to project site. Contractor is responsible for moisture conditioning, placing, compacting, and all other handling of any owner-furnished fill or base material. Bids will be received for single lump sum contract.

Owner anticipates that the Project's total bid price will be approximately \$5,820,745. The Project is expected to be completed by September 3, 2027.

**Obtaining Bidding Documents:**

Information and Bidding Documents for Bids for the Project is posted at <https://contractors.jonesanddemille.com/>.

To receive a link to view and download the Bidding Documents, and to be added to the plan holders list, prospective Bidders must email Tracie Mead at [tracie.m@jonesanddemille.com](mailto:tracie.m@jonesanddemille.com) and include the company name, contact person, phone number, and email address. All addenda, plan holders list updates, reports, and other project updates relevant to submitting a Bid will be distributed by email to the plan holders list only.

The Issuing Office for the Bidding Documents is: Jones & DeMille Engineering, Inc., 1675 South Highway 10, Price, Utah 84501. Only electronic copies of Bidding Documents will be issued.

Neither Owner nor Engineer will be responsible for full or partial sets of Bidding Documents, including addenda, if any, obtained from sources other than the Issuing Office through the process described above.

Questions are due in writing to Wyatt Hansen, Project Manager, at [wyatt.h@jonesanddemille.com](mailto:wyatt.h@jonesanddemille.com) on or before Friday, May 29, 2026, by 5:00 pm with a courtesy copy (cc) to [tracie.m@jonesanddemille.com](mailto:tracie.m@jonesanddemille.com).

**Pre-bid Conference:**

A pre-bid conference for the Project will be held on Wednesday, May 20, 2026 at 2:00 pm local time at Jones and DeMille Engineering 1675 South Highway 10 Price, UT, 84501. Attendance at the pre-bid conference is encouraged but not required.

**Instructions to Bidders:**

For further requirements regarding bid submittal, qualifications, procedures, and contract award, refer to the Instructions to Bidders that are included in the Bidding Documents. The Owner may reject any or all bids submitted.

**Issued by:**

Owner: **WELLINGTON CITY**

By: **Jack Clark**

Title: **Mayor**

Date: **May 13, 2026**

SECTION 01 20 00  
PRICE AND PAYMENT PROCEDURES

PART 1 GENERAL

1.1 SUMMARY

- A. Section Includes:
  - 1. Schedule of Values.
  - 2. Application for Payment.
  - 3. Change procedures.
  - 4. Defect assessment.

1.2 SCHEDULE OF VALUES

- A. Submit printed or electronic PDF file of Schedule of Values on Contractor's standard form.
- B. Submit Schedule of Values as required in General Conditions.
- C. Format: Use Table of Contents of this Project Manual. Identify each line item with number and title of major Specification Section. Also identify mobilization, bonds and insurance, and other related items.
- D. Include within each line item, direct proportional amount of Contractor's overhead and profit.
- E. Revise Schedule of Values to list approved Change Orders with each Application for Payment.

1.3 APPLICATION FOR PAYMENT

- A. Submit one copy of each Application for Payment on Contractor's standard form.
- B. Submit updated Progress Schedule with each Application for Payment.
- C. Payment Period: Submit at monthly intervals as agreed upon at Preconstruction Meeting.
- D. Substantiating Data: When Architect requires substantiating information, submit data justifying dollar amounts in question.

1.4 CHANGE PROCEDURES

- A. Submit name of individual who is authorized to receive change documents and is responsible for informing others in Contractor's employ or Subcontractors of changes to Work.

- B. Carefully study and compare Contract Documents before proceeding with fabrication and installation of Work. Promptly advise Architect of any error, inconsistency, omission, or apparent discrepancy.
- C. Requests for Interpretation (RFI) and Clarifications: Allot time in construction scheduling for handling queries and clarifications.
- D. Use Contractor's standard form for requesting interpretations.
- E. Architect may respond with direct answer on Request for Interpretation form, Field Order, or Work Change Directive.
- F. Substitutions are to be requested and reviewed by Architect prior to submittal of bids as indicated in Instructions to Bidders.
- G. Execution of Change Orders: Architect will issue Change Orders for signatures of parties as provided in General Conditions.
- H. Correlation of Contractor Submittals:
  - 1. Promptly revise Application for Payment forms to record each authorized Change Order as separate line item and adjust Contract Price.
  - 2. Promptly revise Progress Schedule to reflect change in Contract Time, revise sub-schedules to adjust times for other items of Work affected by change, and resubmit.
  - 3. Promptly enter changes in Record Documents.

## 1.5 DEFECT ASSESSMENT

- A. Replace Work, or portions of Work, not conforming to specified requirements.
- B. If, in opinion of Architect, it is not practical to remove and replace Work, Architect will direct appropriate remedy or adjust payment.
  - 1. Defective Work may remain, but unit sum/price will be reduced up to 50 percent at discretion of Architect.
  - 2. Defective Work will be partially repaired according to instructions of Architect, and unit sum/price will be adjusted to new sum/price at discretion of Architect.
  - 3. Individual Specification Sections may modify these options or may identify specific formula or percentage sum/price reduction.
- C. Authority of Architect to assess defects and identify payment adjustments is final.
- D. Nonpayment for Rejected Products: Payment will not be made for rejected products for any of the following reasons:
  - 1. Products wasted or disposed of in manner that is not acceptable.

2. Products determined as unacceptable before or after placement.
3. Products not completely unloaded from transporting vehicle.
4. Products placed beyond lines and levels of the required Work.
5. Products remaining on hand after completion of Work.
6. Loading, hauling, and disposing of rejected products.

## 1.6 ALLOWANCES

### A. Audiovisual Systems Programming Allowance:

1. Cost Included in Audiovisual Systems Programming Allowance:
  - a. Cost of contracting Resolut Group for performance AV systems programming services as specified in Section 27 4100.
  - b. Programming of control processing and digital signal processing for AV subsystems as defined in Section 27 4100, Part 2.4.
  - c. 15 percent Contractor markup.
2. Cost Not Included in Audiovisual Systems Programming Allowance but Included in Contract Sum/Price:
  - a. Furnishing and installing all AV equipment, cabling, conduit, and ancillary components specified in Section 27 4100.
  - b. Configuration of general AV subsystem components, including providing IP addresses, MAC addresses, and serial numbers to Resolut Group.
  - c. Cost of re-programming or additional programming fees resulting from contractor-initiated deviations from approved shop drawings.
  - d. Costs associated with change orders affecting programming scope after final reviewed shop drawings are issued.
  - e. Any review fees associated with the Contractor electing to provide their own programming services in lieu of Resolut Group.

### B. Digital Marquee Sign Allowance:

1. Cost Included in Digital Marquee Sign Allowance:
  - a. Furnishing and installing a double-sided LED electronic marquee sign as shown on the Civil drawings.
  - b. Concrete footing design and construction supporting the sign structure.
  - c. Natural stone veneer wrapping the base and sides of the sign structure, matching the exterior building stone specified elsewhere.
  - d. Precast concrete cap at the top of the stone base.
  - e. Coordination with and procurement from an approved sign vendor. The Owner has identified Creative Signs and Graphics of Spanish Fork, Utah as a preferred vendor; the

- Contractor may propose an alternate vendor subject to Owner and Architect approval prior to procurement.
- f. Submittal of complete shop drawings for the full sign assembly — including footing, stone base, precast cap, and LED cabinet — to the Engineer and Architect for review and approval prior to fabrication or construction. No work on the sign structure shall commence prior to approved shop drawings.
  - g. 15 percent Contractor markup.
2. Cost Not Included in Digital Marquee Sign Allowance but Included in Contract Sum/Price:
- a. Electrical service, conduit, trenching, and connection to the sign — covered under the electrical scope shown on the drawings.
  - b. Costs associated with re-work, re-fabrication, or redesign resulting from the Contractor proceeding without approved shop drawings.
  - c. Costs of landscape restoration beyond the immediate sign base footprint disturbed during installation.
  - d. Sign permit fees, if required separately from the building permit.

PART 2 EXECUTION - Not Used

END OF SECTION

**DOCUMENT 00 41 11  
BID FORM FOR CONSTRUCTION CONTRACT**

**PROJECT: WELLINGTON CITY ADMINISTRATION AND EMERGENCY SERVICES BUILDING**

The terms used in this Bid with initial capital letters have the meanings stated in the Instructions to Bidders, the General Conditions, and the Supplementary Conditions.

**ARTICLE 1—OWNER AND BIDDER**

- 1.01 This Bid is submitted to: Wellington City, c/o Jones & DeMille Engineering, 1675 South Highway 10, Price, UT 84501.
- 1.02 The undersigned Bidder proposes and agrees, if this Bid is accepted, to enter into an Agreement with Owner in the form included in the Bidding Documents to perform all Work as specified or indicated in the Bidding Documents for the prices and within the times indicated in this Bid and in accordance with the other terms and conditions of the Bidding Documents.

**ARTICLE 2—ATTACHMENTS TO THIS BID**

- 2.01 The following documents are submitted with and made a condition of this Bid:
- A. Required Bid security.
  - B. Evidence of authority to do business in the state of the Project; or a written covenant to obtain such authority within the time for acceptance of Bids.
  - C. Contractor’s license number as evidence of Bidder’s State Contractor’s License or a covenant by Bidder to obtain said license within the time for acceptance of Bids.
  - D. Required Bidder qualification information as indicated in Article 3 of the Instructions to Bidders.

**ARTICLE 3—BASIS OF BID—LUMP SUM BID AND UNIT PRICES**

3.01 *Lump Sum Bids*

- A. Bidder will complete the Work in accordance with the Contract Documents for the following lump sum (stipulated) price:
- 1. Lump Sum Price (Single Lump Sum)

Lump Sum Bid Price	\$
--------------------	----

- B. All specified cash allowance(s) are included in the price(s) set forth below and have been computed in accordance with Section 3.8 of AIA Document A201 – 2017 General Conditions.

Lump Sum for Cash Allowance 1 – AV Programming	\$9,400.00
Lump Sum for Cash Allowance 2 – Electronic Marquee	\$55,000.00
Total for all Lump Sum for Cash Allowances	\$64,400.00

3.02 *Total Bid Price (Lump Sum and Cash Allowances)*

Total Bid Price (Total of all Lump Sum and Cash Allowances)	\$
---	----

**ARTICLE 4—BASIS OF BID—COST-PLUS FEE - DELETED**

**ARTICLE 5—PRICE-PLUS-TIME BID - DELETED**

**ARTICLE 6—TIME OF COMPLETION**

- 6.01 Bidder agrees that the Work will be substantially complete and will be completed and ready for final payment on or before the dates or within the number of calendar days indicated in the Agreement.
- 6.02 Deleted.
- 6.03 Deleted.
- 6.04 Bidder accepts the provisions of the Agreement as to liquidated damages.

**ARTICLE 7—BIDDER’S ACKNOWLEDGEMENTS: ACCEPTANCE PERIOD, INSTRUCTIONS, AND RECEIPT OF ADDENDA**

7.01 *Bid Acceptance Period*

- A. This Bid will remain subject to acceptance for 60 days after the Bid opening, or for such longer period of time that Bidder may agree to in writing upon request of Owner.

7.02 *Instructions to Bidders*

- A. Bidder accepts all of the terms and conditions of the Instructions to Bidders, including without limitation those dealing with the disposition of Bid security.

7.03 *Receipt of Addenda*

- A. Bidder hereby acknowledges receipt of the following Addenda:

Addendum Number	Addendum Date

**ARTICLE 8—BIDDER’S REPRESENTATIONS AND CERTIFICATIONS**

8.01 *Bidder’s Representations*

- A. In submitting this Bid, Bidder represents the following:
  - 1. Bidder has examined and carefully studied the Bidding Documents, including Addenda.
  - 2. Bidder has visited the Site, conducted a thorough visual examination of the Site and adjacent areas, and become familiar with the general, local, and Site conditions that may affect cost, progress, and performance of the Work.
  - 3. Bidder is familiar with all Laws and Regulations that may affect cost, progress, and performance of the Work.
  - 4. Bidder has carefully studied the reports of explorations and tests of subsurface conditions at or adjacent to the Site and the drawings of physical conditions relating to existing surface or subsurface structures at the Site that have been identified in the

Supplementary Conditions, with respect to the Technical Data in such reports and drawings.

5. Bidder has carefully studied the reports and drawings relating to Hazardous Environmental Conditions, if any, at or adjacent to the Site that have been identified in the Supplementary Conditions, with respect to Technical Data in such reports and drawings.
6. Bidder has considered the information known to Bidder itself; information commonly known to contractors doing business in the locality of the Site; information and observations obtained from visits to the Site; the Bidding Documents; and the Technical Data identified in the Supplementary Conditions or by definition, with respect to the effect of such information, observations, and Technical Data on (a) the cost, progress, and performance of the Work; (b) the means, methods, techniques, sequences, and procedures of construction to be employed by Bidder, if selected as Contractor; and (c) Bidder's (Contractor's) safety precautions and programs.
7. Based on the information and observations referred to in the preceding paragraph, Bidder agrees that no further examinations, investigations, explorations, tests, studies, or data are necessary for the performance of the Work at the Contract Price, within the Contract Times, and in accordance with the other terms and conditions of the Contract.
8. Bidder is aware of the general nature of work to be performed by Owner and others at the Site that relates to the Work as indicated in the Bidding Documents.
9. Bidder has given Engineer written notice of all conflicts, errors, ambiguities, or discrepancies that Bidder has discovered in the Bidding Documents, and of discrepancies between Site conditions and the Contract Documents, and the written resolution thereof by Engineer is acceptable to Contractor.
10. The Bidding Documents are generally sufficient to indicate and convey understanding of all terms and conditions for performance and furnishing of the Work.
11. The submission of this Bid constitutes an incontrovertible representation by Bidder that without exception the Bid and all prices in the Bid are premised upon performing and furnishing the Work required by the Bidding Documents.

#### 8.02 *Bidder's Certifications*

- A. The Bidder certifies the following:
  1. This Bid is genuine and not made in the interest of or on behalf of any undisclosed individual or entity and is not submitted in conformity with any collusive agreement or rules of any group, association, organization, or corporation.
  2. Bidder has not directly or indirectly induced or solicited any other Bidder to submit a false or sham Bid.
  3. Bidder has not solicited or induced any individual or entity to refrain from bidding.
  4. Bidder has not engaged in corrupt, fraudulent, collusive, or coercive practices in competing for the Contract. For the purposes of this Paragraph 8.02.A:
    - a. Corrupt practice means the offering, giving, receiving, or soliciting of anything of value likely to influence the action of a public official in the bidding process.

- b. Fraudulent practice means an intentional misrepresentation of facts made (a) to influence the bidding process to the detriment of Owner, (b) to establish bid prices at artificial non-competitive levels, or (c) to deprive Owner of the benefits of free and open competition.
- c. Collusive practice means a scheme or arrangement between two or more Bidders, with or without the knowledge of Owner, a purpose of which is to establish bid prices at artificial, non-competitive levels.
- d. Coercive practice means harming or threatening to harm, directly or indirectly, persons or their property to influence their participation in the bidding process or affect the execution of the Contract.

**(Remainder of page intentionally left blank.)**

BIDDER hereby submits this Bid as set forth above:

Bidder:

\_\_\_\_\_  
*(typed or printed name of organization)*

By: \_\_\_\_\_  
*(individual's signature)*

Name: \_\_\_\_\_  
*(typed or printed)*

Title: \_\_\_\_\_  
*(typed or printed)*

Date: \_\_\_\_\_  
*(typed or printed)*

*If Bidder is a corporation, a partnership, or a joint venture, attach evidence of authority to sign.*

Attest: \_\_\_\_\_  
*(individual's signature)*

Name: \_\_\_\_\_  
*(typed or printed)*

Title: \_\_\_\_\_  
*(typed or printed)*

Date: \_\_\_\_\_  
*(typed or printed)*

Address for giving notices:

\_\_\_\_\_  
\_\_\_\_\_

Bidder's Contact:

Name: \_\_\_\_\_  
*(typed or printed)*

Title: \_\_\_\_\_  
*(typed or printed)*

Phone: \_\_\_\_\_

Email: \_\_\_\_\_

Address: \_\_\_\_\_  
\_\_\_\_\_  
\_\_\_\_\_

Bidder's Contractor License No.: \_\_\_\_\_



5. If other than a Corporation or Partnership, describe the organization and name principals:

---

---

6. What percent of work do you normally perform with your own forces: \_\_\_\_\_

List trades:

---

---

---

---

---

---

7. Have you ever failed to complete any work awarded to you? If so, indicated when, where and why.

---

---

---

---

8. Has any officer or partner of your organization ever been an officer or partner of another organization that failed to complete a construction contract? \_\_\_\_\_

If so, what were the circumstances?

---

---

---

---

9. List major construction projects your organization has under contract on this date:

Project Name	Owner	A/E	Contract Amount	Contract Date	Percent Complete	Scheduled Completion
_____						
_____						
_____						
_____						

10. List major construction projects your organization has completed in the past 5 years:

Project Name	Owner	A/E	Contract Amount	Date Awarded	Date Completed	% of Own Forces
_____						
_____						
_____						
_____						

11. List the construction experience of the principal individuals in your organization:

Individual's Name	Construction Experience (years)	Present Position & Years of Experience	Dollar Volume Responsibility	Previous Position & Years of Experience
_____				
_____				
_____				
_____				

12. List states and categories in which your organization is legally qualified to do business:

\_\_\_\_\_

\_\_\_\_\_

\_\_\_\_\_

\_\_\_\_\_

13. Project references and performance information:

List and provide company Project References and performance information for at least ~~{2 similar mountain spring development and at least two (2) cast-in-place concrete tank construction}~~ 2 similar building projects for a Pre-Engineered Metal Building and at least 2 similar building projects for a single story wood framed building of similar size and use. List the project references below and provide additional information by completing a Project Reference Form at the end of this Exhibit for each listed reference project.

Project Name and Location	Owner	Engineer	Contract Value	Year Completed

14. Name of bonding and insurance companies, and name and address of agents:

Name of Company	Name of Agent	Address of Agent	Maximum Bonding Capacity

15. The undersigned agrees to furnish, upon request by the Owner, within 48 hours after bid proposal opening, a current Statement of Financial Conditions, including the Contractor's latest regular dated financial statement of balance sheet which must contain the following items:

Current assets: Cash, joint venture accounts, accounts receivable, notes receivable, accrued interest on notes, deposits, and materials, and prepaid expenses, next fixed assets and other assets.

Current liabilities: Accounts payable, notes payable, accrued interest on notes, provision for income taxes, advances received from owners, accrued salaries, accrued payroll taxes, other liabilities, and capital (capital stock, authorized and outstanding shares par values, earned surplus).

Date of statement of balance sheet: \_\_\_\_\_

Name of firm preparing statement: \_\_\_\_\_

By (Agent and Capacity): \_\_\_\_\_

16. Dated at \_\_\_\_\_, this

\_\_\_\_\_ day of \_\_\_\_\_ 20\_\_\_\_.  
(Day) (Month) (Year)

Name of Organization: \_\_\_\_\_

By: \_\_\_\_\_

Title: \_\_\_\_\_

17. NOTARIZATION:

State of: \_\_\_\_\_

County of: \_\_\_\_\_

I, \_\_\_\_\_ being duly sworn deposes and say that (he/she) is the  
\_\_\_\_\_ of \_\_\_\_\_ Contractor(s)  
and that the answers to the foregoing questions and all statements and information contained on  
attachments herein contained are true and correct.

Subscribed and sworn before me this

\_\_\_\_\_ day of \_\_\_\_\_ 20\_\_\_\_.  
(Day) (Month) (Year)

Notary Public: \_\_\_\_\_

My commission expires: \_\_\_\_\_

**SIMILAR PROJECT REFERENCE FORM**  
(Complete for at least 2 projects)

**Project No:** \_\_\_\_\_

Project Name and Location: \_\_\_\_\_

Bid Amount: \_\_\_\_\_

Final Contract Amount: \_\_\_\_\_ Year Completed: \_\_\_\_\_

Contract Completion Time: \_\_\_\_\_ Days

Dollar Amount and Number of Change Orders: \_\_\_\_\_

Actual Completion Time: \_\_\_\_\_ Days

Description of Work:

General Overview: \_\_\_\_\_

New Facility or Retrofit/ Expansion? \_\_\_\_\_

**[Spring Flow Rates:]** Square Footage: \_\_\_\_\_

**[Concrete Tank Size:]** Construction Type:- \_\_\_\_\_

Other Information? (Attach as needed) \_\_\_\_\_

\_\_\_\_\_

Names Key Contractor Personnel:

Project Manager \_\_\_\_\_

Project Engineer \_\_\_\_\_

Superintendent \_\_\_\_\_

Are all of these persons still employed by your organization \_\_\_\_\_

If no, name those employee(s) not currently employed \_\_\_\_\_

Name and phone number of currently employed individual at your organization who is familiar with this Project. \_\_\_\_\_

Name, Address, and Telephone Number of Owner (including name and telephone number of contact person):

\_\_\_\_\_

\_\_\_\_\_

\_\_\_\_\_

Name, Address, and Telephone Number of Engineer if applicable (including name and telephone number of contact person):

---

---

---

Name, Address, and Telephone Number of Construction Manager employed by Owner

---

---

Amount and number of claims resulting in arbitration or litigation:

---

---

Amount of Settlement: \_\_\_\_\_

Further Information of Claims: \_\_\_\_\_

---

---

---

---

---

(Repeat for other projects)

END OF DOCUMENT

SECTION 05 31 23  
STEEL ROOF DECKING

PART 1 GENERAL

1.1 SUMMARY

- A. Section Includes:
  - 1. Steel roof deck and accessories.
  - 2. Framing for openings up to and including 18 inches.
  - 3. Bearing plates and angles.

1.2 PERFORMANCE REQUIREMENTS

- A. Design deck to accommodate section modulus as indicated in Drawings and maximum vertical deck deflection of 1/240.
- B. Design deck with maximum lateral diaphragm deflection of 1/500 wall height.

1.3 SUBMITTALS

- A. Shop Drawings: Indicate deck plan, support locations, projections, openings and reinforcement and pertinent details, and accessories.
- B. Product Data: Deck profile characteristics and dimensions, structural properties, and finishes.
- C. Manufacturer's installation instructions.
- D. Manufacturer's Certificates: Certify Products meet or exceed specified requirements.
- E. Welders Certificates: Certify welders employed on Work, verifying AWS qualification within previous 12 months.

1.4 QUALITY ASSURANCE

- A. Perform Work according to ANSI/SDI RD-2017 Standard for Steel Roof Deck.
- B. Installer: Company specializing in performing Work of this Section with minimum three years' experience.
- C. Design deck layout, spans, fastening, and joints under direct supervision of professional engineer experienced in design of this Work and licensed in State of Utah.

## 1.5 DELIVERY, STORAGE, AND HANDLING

- A. Cut plastic wrap to encourage ventilation.
- B. Separate sheets and store deck on dry wood sleepers; slope for positive drainage.

## PART 2 PRODUCTS

### 2.1 MATERIALS

- A. Manufacturers:
  - 1. Nucor, Vulcraft
  - 2. Substitutions: Permitted.
- B. Steel Deck: profile, grade, gauge, section properties as indicated on Drawings.
- C. Bearing Angles: ASTM A36/A36M steel, unfinished, .
- D. Welding Materials: AWS D1.1.

### 2.2 FABRICATION

- A. Metal Deck: Sheet steel, configured as follows:
  - 1. Span Design: As indicated on Drawings.
  - 2. Minimum Metal Thickness Excluding Finish: As indicated on Drawings.
  - 3. Minimum Section Properties (per foot width): As indicated on Drawings.
  - 4. Minimum Allowable Diaphragm Shear: 920 plf for wind loads, 800 plf for seismic loads.
  - 5. Nominal Height: As indicated on Drawings.
  - 6. Formed Sheet Width: As indicated on Drawings.
  - 7. Side Joints: lapped.
  - 8. Flute Sides: plain vertical face.
- B. Related Deck Accessories: Metal closure strips, 20 gage thick sheet steel; of profile and size matching steel deck.
- C. Fasteners: Galvanized hardened steel, self tapping.

## PART 3 EXECUTION

### 3.1 INSTALLATION

- A. Erect metal deck according to SDI Manual.

- B. Bear deck on steel support surfaces at masonry walls with 4 inch minimum bearing. Align and level.
- C. Bear deck on interior steel supports with 1-1/2 inch minimum bearing. Align and level.
- D. Fasten deck to steel support members at ends and intermediate supports as indicated on Drawings.
- E. Weld according to AWS D1.1.
- F. Mechanically fasten male/female side laps as indicated on Drawings.
- G. Reinforce steel deck openings from 6 to 18 inches in size with 2 x 2 x 1/4 inch steel angles. Place framing angles perpendicular to flutes; extend minimum two flutes beyond each side of opening and mechanically attach to deck at each flute.
- H. Install 6 inch minimum wide sheet steel cover plates, of same thickness as deck, where deck changes direction. Fusion weld 12 inches o.c. maximum.
- I. Install sheet steel closures and angle flashings to close openings between deck and walls, columns, and openings.
- J. Install single row of foam flute closures above walls and partitions perpendicular to deck flutes.
- K. Position roof sump pans with flange bearing on top surface of deck. Fusion weld at each deck flute.
- L. Immediately after welding deck and other metal components in position, coat welds, burned areas, and damaged surface coating, with touch-up prime paint.

### 3.2 FIELD QUALITY CONTROL

- A. Welding: Inspect welds according to AWS D1.1 and as indicated on Drawings.

END OF SECTION

SECTION 06 41 16  
PLASTIC-LAMINATE-CLAD ARCHITECTURAL CABINETS

PART 1 GENERAL

1.1 SUMMARY

- A. Section Includes:
  - 1. Plastic-laminate-clad architectural cabinets.
  - 2. Cabinet hardware and accessories.
  - 3. Miscellaneous materials.
- B. Related Requirements:
  - 1. Section 06 10 00 – Rough Carpentry.
  - 2. Section 08 80 00 – Glazing.

1.2 REFERENCE STANDARDS

- A. American National Standards Institute (ANSI):
  - 1. ANSI A208.1 – American National Standard: Particleboard.
  - 2. ANSI A208.2 – American National Standard: Medium Density Fiberboard (MDF) for Interior Applications.
  - 3. ANSI/BHMA A156.9 – Cabinet Hardware.
  - 4. ANSI/BHMA A156.11 – Cabinet Locks.
- B. Architectural Woodwork Institute (AWI):
  - 1. Architectural Woodwork Standards.
  - 2. AWI Quality Certification Program.
- C. ASTM International (ASTM):
  - 1. ASTM C1048 – Standard Specification for Heat-Strengthened and Fully Tempered Flat Glass.
- D. Glazing Association of North America (GANA):
  - 1. GANA Glazing Manual.
- E. International Organization for Standardization (ISO):
  - 1. ISO 4583 – Plastics – Epoxy Resins and Related Materials – Determination of Easily Saponifiable Chlorine.
  - 2. ISO 4586-3 – High-Pressure Decorative Laminates (HPL, HPDL) – Sheets Based on Thermosetting Resins (Usually Called Laminates) – Part3: Classification and Specifications for Laminates Less Than 2 mm Thick and Intended for Bonding to Supporting Substances.
- F. Product Standard (PS):
  - 1. DOC PS 1 – Voluntary Product Standard: Structural Plywood.

### 1.3 COORDINATION

- A. Coordinate sizes and locations of framing, blocking, furring, reinforcements, and other related units of Work specified in other Sections to support loads imposed by installed and fully loaded cabinets.

### 1.4 ACTION SUBMITTALS

- A. Product Data
  - 1. Plastic-laminate-clad architectural cabinets.
  - 2. Cabinet hardware and accessories.
  - 3. Miscellaneous materials.
- B. Product Data Submittals: Provide for each product.
- C. Shop Drawings:
  - 1. Include plans, elevations, sections, and attachment details.
  - 2. Show large-scale details.
  - 3. Show locations and sizes of furring, blocking, and hanging strips, including concealed blocking and reinforcement specified in other Sections.
  - 4. Show locations and sizes of cutouts and holes for items installed in plastic-laminate architectural cabinets.
  - 5. Apply AWI Quality Certification Program label to Shop Drawings.
- D. Samples: Submit for each exposed product and for each color and texture specified, in manufacturer's or manufacturer's standard size.
- E. Samples for Initial Selection: Provide for each type of exposed finish.
- F. Samples for Verification:
  - 1. Plastic Laminates:
    - a. 12-by-12 inches, for each type, color, pattern, and surface finish required.
    - b. Provide one sample applied to core material with specified edge material applied to one edge.
  - 2. Exposed Cabinet Hardware and Accessories: One full-size unit for each type and finish.

### 1.5 QUALITY ASSURANCE

- A. Manufacturer's Qualifications: Employs skilled workers who custom fabricate products similar to those required for this Project and whose products have record of successful in-service performance.

(Remainder of page intentionally left blank.)

## 1.6 DELIVERY, STORAGE, AND HANDLING

- A. Do not deliver cabinets until painting and similar finish operations that might damage architectural cabinets have been completed in installation areas. Store cabinets in installation areas or in areas where environmental conditions comply with Field Condition requirements specified in this Section.

## 1.7 FIELD CONDITIONS

- A. Field Measurements:
  - 1. Locate concealed framing, blocking, and reinforcements that support cabinets by field measurements before being enclosed/concealed by construction and indicate measurements on Shop Drawings.
  - 2. Where cabinets are indicated to fit to other construction, verify dimensions of other construction by field measurements before fabrication, and indicate measurements on Shop Drawings.
  - 3. Coordinate fabrication schedule with construction progress to avoid delaying the Work.
- B. Established Dimensions: Where cabinets are indicated to fit to other construction, establish dimensions for areas where cabinets are to fit. Provide allowance for trimming at site, and coordinate construction to ensure that actual dimensions correspond to established dimensions.

## PART 2 PRODUCTS

### 2.1 PLASTIC-LAMINATE-CLAD ARCHITECTURAL CABINETS

- A. Quality Standard: Unless otherwise indicated, comply with Architectural Woodwork Standards for grades of cabinets indicated for construction, finishes, installation, and other requirements.
- B. Architectural Woodwork Standards Grade: Premium.
- C. Type of Construction: Frameless.
- D. Door and Drawer-Front Style: Full overlay.
  - 1. Reveal Dimension: 1/8-inch.
- E. Exposed Surfaces
  - 1. Plastic-Laminate Grade: HGS.
  - 2. Edges: Grade HGS.
  - 3. Pattern Direction: Vertically for drawer fronts, doors, and fixed panels.

(Remainder of page intentionally left blank.)

- F. Semi-exposed Surfaces:
  - 1. Surfaces Other Than Drawer Bodies: High-pressure decorative laminate, ISO 4586-3.
    - a. Edges of Plastic-Laminate Shelves: HGS.
    - b. For semi-exposed backs of panels with exposed plastic-laminate surfaces, provide surface of high-pressure decorative laminate, ISO 4586-3, grade to match exposed surface.
  - 2. Drawer Sides and Back: Ply-score.
  - 3. Drawer Bottoms: Ply-score.
- G. **Concealed Backs of Panels: White Melamine. Use 3/4 inch plastic laminate back panel where back of cabinet is exposed.**
- H. Drawer Construction: Fabricate with exposed fronts fastened to sub-front with mounting screws from interior of body.
  - 1. Join sub-fronts, backs and sides with **dowels or screws**.
- I. Colors, Patterns, and Finishes: Provide materials and products that result in colors and textures of exposed laminate surfaces complying with following requirements:
  - 1. As selected by Architect from laminate manufacturer's full range in following categories:
    - a. Wood grain matte finish.

## 2.2 WOOD MATERIALS

- A. Wood Products: Provide materials that comply with requirements of referenced quality standard for each type of architectural cabinet and quality grade specified unless otherwise indicated.
  - 1. Wood Moisture Content: 4 to 9 percent.
- B. Composite Wood Products: Provide materials that comply with requirements of referenced quality standard for each type of architectural cabinet and quality grade specified unless otherwise indicated.
  - 1. Medium-Density Fiberboard (MDF): ANSI A208.2, Grade 130.
  - 2. Particleboard (Medium Density): ANSI A208.1, Grade M-2.
  - 3. Softwood Plywood: DOC PS 1, medium-density overlay.

(Remainder of page intentionally left blank.)

## 2.3 CABINET HARDWARE AND ACCESSORIES

- A. Frameless Concealed Hinges (European Type): ANSI/BHMA A156.9, B01602, 100 degrees of opening, self-closing. Blum 110-degree overlay.
- B. Catches: Magnetic catches, ANSI/BHMA A156.9, B03141.

- C. Shelf Rests: ANSI/BHMA A156.9, B04013; metal.
- D. Drawer Slides: ANSI/BHMA A156.9.
  - 1. Heavy Duty (Grade 1 and Grade 2): Undermount and extending under bottom edge of drawer with soft close Blum Tandem.
  - 2. General-purpose drawers more than 3 inches high, but not more than 6 inches high and not more than 24 inches wide, provide 75-pound load capacity.
- E. Door Locks: ANSI/BHMA A156.11, E07121.
- F. Drawer Locks: ANSI/BHMA A156.11, E07041.
- G. Door and Drawer Silencers: Clear rubber.
- H. Tempered Float Glass for Cabinet Doors: ASTM C1048, Kind FT, Condition A, Type I, Class 1 (clear), Quality-Q3, 6 millimeters thick unless otherwise indicated.
- I. Grommets for Cable Passage: 2-inch OD, molded-plastic grommets and matching plastic caps with slot for wire passage.
  - 1. Color: Black.
- J. Exposed Hardware Finishes: Top knobs model 2631 black for doors and drawers.
- K. For concealed hardware, provide manufacturer's standard finish that complies with product class requirements in ANSI/BHMA A156.9.

## 2.4 MISCELLANEOUS MATERIALS

- A. Furring, Blocking, Shims and Hanging Strips: Softwood or hardwood lumber, kiln-dried to less than 15 percent moisture content.
- B. Anchors: Select material, type, size, and finish required for each substrate for secure anchorage. Provide metal expansion sleeves or expansion bolts for post-installed anchors. Use nonferrous metal or hot-dip galvanized anchors and inserts at inside face of exterior walls and at floors.
- C. Adhesive for Bonding Plastic Laminate: As selected by fabricator to comply with requirements.
  - 1. Adhesive for Bonding Edges: Hot-melt adhesive.

## 2.5 FABRICATION

- A. Fabricate architectural cabinets to dimensions, profiles, and details indicated.

- B. Complete fabrication, including assembly and hardware application, to maximum extent possible before shipment to Project site. Disassemble components only as necessary for shipment and installation. Where necessary for fitting at Site, provide ample allowance for scribing, trimming, and fitting.
- C. Shop-cut openings to maximum extent possible to receive hardware, appliances, electrical work, and similar items. Locate openings accurately and use templates or roughing-in diagrams to produce accurately sized and shaped openings. Sand edges of cutouts to remove splinters and burrs.
- D. Install glass to comply with applicable requirements in Section 08 80 00 and in GANA Glazing Manual.
  - 1. For glass in frames, secure glass with removable stops.

## PART 3 EXECUTION

### 3.1 PREPARATION

- A. Before installation, condition cabinets to humidity conditions in installation areas for minimum 72 hours.

### 3.2 INSTALLATION

- A. Architectural Woodwork Standards Grade: Install cabinets to comply with quality standard grade of item to be installed.
- B. Assemble cabinets and complete fabrication at Project site to extent that fabrication was not completed in shop.
- C. Anchor cabinets to anchors or blocking built in or directly attached to substrates. Secure with wafter-head cabinet installation screws.
- D. Install cabinets level, plumb, and true in line to tolerance of 1/8-inch in 96 inches using concealed shims.
  - 1. Scribe and cut cabinets to fit adjoining work, refinish cut surfaces, and repair damaged finish at cuts.
  - 2. Install cabinets without distortion so doors and drawers fit openings and are accurately aligned. Adjust hardware to center doors and drawers in openings and to provide unencumbered operation. Complete installation of hardware and accessory items as indicated.
  - 3. Fasten wall cabinets through back, near top and bottom, and at ends not more than 16 inches on-center.

### 3.3 ADJUSTING AND CLEANING

- A. Repair damaged and defective cabinets, where possible, to eliminate functional and visual defects. Where not possible to repair, replace architectural cabinets. Adjust joinery for uniform appearance.
- B. Clean, lubricate, and adjust hardware.
- C. Clean cabinets on exposed and semi-exposed surfaces.

END OF SECTION

SECTION 08 23 21  
FOUR FOLD DOOR SYSTEM

PART 1 GENERAL

1.1 SUMMARY

- A. Section Includes: Four-fold metal doors with surface mounted angle frames.
  - 1. Operation of Four-Fold metal doors includes overhead mounted electromechanical operator.

1.2 REFERENCE STANDARDS

- A. American Institute of Steel Construction (AISC):
  - 1. AISC Steel Construction Manual.
- B. (ASCE):
  - 1. ASCE 7 – Minimum Design Loads and Associated Criteria for Buildings and Other Structures.
- C. ASTM International (ASTM):
  - 1. ASTM A500 – Standard Specification for Cold-Formed Welded and Seamless Carbon Steel Structural Tubing in Rounds and Shapes.
  - 2. ASTM A513 – Standard Specification for Electric-Resistance-Welded Carbon and Alloy Steel Mechanical Tubing
  - 3. ASTM A653 – Standard Specification for Steel Sheet, Zinc-Coated (Galvanized) or Zinc-Iron Alloy-Coated (Galvannealed) by the Hot-Dip Process.
- D. National Electrical Manufacturers Association (NEMA):
  - 1. NEMA 250 - Enclosures for Electrical Equipment (1000 Volts Maximum).
- E. National Fire Protection Association (NFPA):
  - 1. NFPA 70 – National Electrical Code (NEC).
- F. Underwriters Laboratories (UL):
  - 1. UL325 – Standard for Door, Drapery, Gate, Louver, and Window Operators and Systems.

1.3 SUBMITTALS

- A. Product Data for each type of product specified consisting of manufacturer's technical Product Data and installation instructions for each type of door required, including data substantiating that products comply with requirements.

- B. Shop Drawings: Show fabrication and installation of Four-Fold metal doors including plans, elevations, sections, details of components, hardware, operating mechanism, and attachments to other units of Work. Include wiring diagrams for coordination with electrical trade.
- C. Reference list including five successful installations of this type of door within the past two years.

#### 1.4 QUALITY ASSURANCE

- A. Tolerances: Designed to withstand external or internal horizontal wind loads of up to 120 miles per hour (3 second gust) per ASCE 7-16 or up to 25 pound square force (Allowable Stress Design) and 40 pounds per square foot (Load and Resistance Factor Design).
- B. Maximum Allowable Deflection: 1/80 of the span.
- C. Limit fiber stresses in main members to 27,000 pounds per square inch.
- D. Steel Frames: Designed in accordance with AISC Steel Construction Manual.
- E. Door manufacturers: Minimum 10 years' experience in manufacturing four-fold door systems.

#### 1.5 DELIVERY, STORAGE AND HANDLING

- A. Store delivered materials and equipment in dry locations with adequate ventilation, free from dust and water.
- B. Permit access for inspection and handling.
- C. Handle materials carefully to prevent damage.

#### 1.6 WARRANTY

- A. Provide door manufacturer's written standard limited warranty for material and workmanship.

### PART 2 Products

#### 2.1 MANUFACTURERS

- A. Basis of Design: Four-Fold industrial metal doors: FF30-Performance Series manufactured by Door Engineering and Manufacturing, 101 Power Dr, Mankato, MN 56001, (800)-959-1352 or equal products by other manufacturers approved in advance.

- B. **Four Fold Door: Model 93 manufactured by Jus Doors, 3714 Alliance Drive, Greensboro, NC, United States, North Carolina**

## 2.2 MATERIALS

- A. Steel Tube: ASTM A513 and ASTM A500.
- B. Steel Sheets: Galvannealed sheets of commercial quality, complying with ASTM A653.
- C. Hardware Manufacturer's standard components
- D. Fasteners: Zinc-Coated Steel.

## 2.3 FOUR-FOLD DOORS

- A. Construction:
  - 1. Door Framing: 11-gauge structural steel tube with 18-gauge galvannealed steel sheet on the exterior and interior faces.
  - 2. Sheeting: Form on vertical edges with no visible welds on the interior or exterior panel faces.
  - 3. Frames and Framing Members: True to dimension and square in all directions.
  - 4. Ensure no door is bowed, warped, or out of line in vertical or horizontal plane of the door opening by more than 1/8 inch in 20 feet. Grind smooth and flush any exposed welds and welds interfering with installation of various parts.
- B. Surface Mounted Frame: Supply angle frame system constructed of minimum L6x4x5/16", designed to anchor to masonry wall construction or fasten/weld to steel structure.
- C. Door Finishes:
  - 1. Interior and Exterior sheeting: PPG Spectracron epoxy primer and polyurethane finish. Architect to select from standard RAL colors (excluding metallic colors).
  - 2. Operator and operating hardware: Powder-coated manufacturer's standard gray.
  - 3. Tracks: galvanized.
  - 4. Surface mounted angle frames: Grey PPG Spectracron epoxy primer.
  - 5. Fasteners: Zinc.
- D. Hardware: Include guide tracks and brackets, trolleys, center guides, and all bolts, nuts, fasteners, etc. necessary for complete installation and operation.
  - 1. Bolt all hardware, including hinges and trolleys, to panel for easy removal for service or panel replacement.

2. Top tracks: Adjustable on end track hangers to allow for adjustment of the door panels in the open position and easily replaceable without removal of the door framing or operators.
- E. Hinges:
1. Jamb Hinges: Dual shear, two thrust bearings, and two needle bearings.
  2. Fold Hinges: Stainless steel, dual shear, and two thrust bearings.
  3. Bearings: Conceal completely within hinge barrel and include grease zerks.
  4. Hinge Pins: Minimum 3/4-inch diameter hardened steel.
- F. Weatherstripping:
1. Material: Adjustable and readily replaceable.
  2. Provide a substantially weather-tight installation.
  3. Weatherstripping at Center: 1/16-inch cloth inserted neoprene, include no exposed fasteners on the exterior face of the panel.
  4. Weatherstripping at Sill: Include two 1/16-inch cloth inserted neoprene sweeps with an aluminum retainer.
  5. Jambs, Head, and Fold Seals: EPDM rubber.
- G. Pinch Points: Provide minimum 3/4-inch gaps at jambs and fold to conform with UL325 pinch point requirements.
- H. Vision Panels: 1-inch insulated, tempered.
1. Glass:
    - a. Pilkington Energy Advantage low-e. Window layout K selected from manufacturer's standard configurations.
    - b. Factory installed and caulked with clear silicone.

## 2.4 OPERATOR

- A. Operator: Overhead mounted electro-mechanical drive unit designed for high cycle operation.
- B. Components: Electric motor, gear reducer, and rotating drive arm, connecting rods attached to rotating drive arm on operator and to control arms attached to jamb door section and to door lintel.
- C. Ensure operator is equipped with following functions:
1. Instantly reversible, open and close rapidly, and start and stop gradually.
  2. Adjustable to allow door to fully clear opening.
  3. Automatically lock door in closed position.
  4. Disengaging mechanism to convert to manual operation.
  5. Adjustable torque sensing to reverse door upon resistance from obstructions.

- D. Connecting Rods: Positive drive, keeping door under firm control at all times. Fitted with spherical bearings and control arms equipped with oil impregnated bronze bearings on polished shafts.
- E. Electric Motor: Sufficiently sized to operate doors under normal operating conditions at maximum 75 percent of rated capacity. Wound for three phase 208/230/480 VAC, 60 Hertz operation.
- F. Electric Controls: Furnished by door manufacturer and complete for each door and built in accordance with latest NEMA standards. Incoming electrical: 208VAC single phase.
  - 1. Control panel assemblies: UL listed as per NFPA70.
  - 2. Controls:
    - a. Include programmable logic controller with digital message display mounted on panel door.
    - b. Include programmable close timers and programmable inputs/outputs.
    - c. Include variable frequency drive with independent adjustment of the opening and closing speeds.
  - 3. Enclosures: NEMA 250, Type 4X with disconnect switch.
  - 4. Pushbuttons (interior) for each door: One momentary pressure three-button push-button station marked "OPEN", "CLOSE" and "STOP".
    - a. NEMA 250, Type 4 enclosures.
  - 5. Provide limit switches to stop travel of door in its fully open or fully closed position.
  - 6. Safety edges: Provide monitored electric safety edges on leading edge of all doors to reverse door upon contact with obstruction.
  - 7. Photo eyes: Provide one exterior, jamb mounted, light curtain type photo eyes, NEMA 250, Type 4 rated. Photo eye shall cover from floor level to 72 inches above floor.
  - 8. Presence Sensor: Provide one interior, overhead mounted, presence sensor BEA IS40P, or equal.
  - 9. Radio controls: Provide one radio receiver and one single button remotes per door. Remotes to open and close doors with single button.
  - 10. Wiring: Door manufacturer to supply controls and components only. Electrical contractor to install controls and furnish and install conduits and wiring for jobsite power and control wiring.

## PART 3 — EXECUTION

### 2.1 INSTALLATION

- A. Install Four-Fold metal doors in strict accordance with approved shop drawings by qualified door erection crews. Completely prepare all door openings prior to installation of doors. Install permanent or temporary

electric wiring to door opening before installation is started and complete promptly so inspection test is not delayed.

- B. Set doors to be plumb, level, and square and with all parts properly fastened and mounted. Test and adjust all moving parts and leave in good operating condition.

## 2.2 ADJUSTING AND CLEANING

- A. Schedule inspection of doors and a complete operating test with Superintendent, Installer, and Architect as soon as erection is complete. Correct any defects noted. After door approval in above test, assume responsibility for any damage or rough handling of doors during construction until the building is turned over to Owner and final inspection is made.
- B. Clean surfaces and repaint abraded or damaged finished surfaces to match factory-applied finish.









END OF SECTION

SECTION 08 71 00  
DOOR HARDWARE

Hardware Group No. 01

For use on Door #(s):  
125

Provide each SGL door(s) with the following:





QT		DESCRIPTION	CATALOG NUMBER		FINISH	MFR
Y						
3	EA	HINGE	5BB1HW 4.5 X 4.5 NRP		630	IVE
1	EA	STOREROOM LOCK	MA581P6 DG		626	FAL
1	EA	LOCK GUARD	LG10		630	IVE
1	EA	SURFACE CLOSER	SC71A SS		689	FAL
1	EA	RAIN DRIP	142AA (AS REQ'D)		AA	ZER
1	SET	GASKETING	429 @ HEAD & JAMBS		AA	ZER
1	EA	DOOR SWEEP	39A		A	ZER
1	EA	SADDLE THRESHOLD	1/2" HIGH X FULL JAMB DEPTH (OR PER SILL DETAILS)		A	ZER
1	EA	DOOR POSITION SWITCH	BY SECURITY. (AS REQ'D)			

OPERATION:  
DOOR IS MONITORED THROUGH ACCESS CONTROL OR SECURITY SYSTEM

Hardware Group No. 02

For use on Door #(s):  
140G

Provide each SGL door(s) with the following:









QT		DESCRIPTION	CATALOG NUMBER		FINISH	MFR
Y						
3	EA	HINGE	5BB1 4.5 X 4.5 NRP		630	IVE
1	EA	STOREROOM LOCK	MA581P6 DG		626	FAL
1	EA	WALL STOP	WS406/407CVX		630	IVE
1	EA	GASKETING	488SBK PSA @ HEAD & JAMBS		BK	ZER
1	EA	DOOR SWEEP	39A		A	ZER

Hardware Group No. 03

For use on Door #(s):

124A                      137                      140E                      140F                      143B

Provide each SGL door(s) with the following:

QT		DESCRIPTION	CATALOG NUMBER		FINISH	MFR
Y						
2	EA	HINGE	5BB1HW 4.5 X 4.5 NRP		630	IVE
1	EA	ELECTRIC HINGE	5BB1HW 4.5 X 4.5 CON TW8		✓ 630	IVE
1	EA	EU STOREROOM LOCK	MA881-24RXP DG CON 24VDC		✓ 626	FAL
1	EA	LOCK GUARD	LG10		630	IVE
1	EA	SURFACE CLOSER	SC71A SS		689	FAL
1	SET	GASKETING	429 @ HEAD & JAMBS		AA	ZER
1	EA	DOOR SWEEP	39A		A	ZER
1	EA	SADDLE THRESHOLD	1/2" HIGH X FULL JAMB DEPTH (OR PER SILL DETAILS)		A	ZER
1	EA	WIRE HARNESS (FROM DEVICE TO HINGE)	CON-XX(LENGTH TO SUIT)		✓	SCH
1	EA	POWER SUPPLY WIRE HARNESS	CON-6W		✓	SCH
1	EA	CREDENTIAL READER	BY SECURITY.		✓	
1	EA	DOOR POSITION SWITCH	BY SECURITY. (AS REQ'D)		✓	
1	EA	LOW VOLTAGE POWER	BY LOW VOLTAGE.		✓	

FALCON MA LOCK IS UNAVAILABLE WITH LX SWITCH VERIFY  
VERIFY CR AT DOOR 140F. SECURITY DIDN'T INCLUDE THIS DOOR









OPERATION:

DOOR IS NORMALLY LATCHED AND SECURED  
PRESENTING VALID CREDENTIAL TEMPORALLY RELEASES LEVER FOR ENTRY  
DOOR IS MONITORED THROUGH ACCESS CONTROL OR SECURITY SYSTEM  
DOOR IS SECURED UPON LOSS OF POWER TO THE LOCK  
FREE EGRESS AT ALL TIMES

Hardware Group No. 04

For use on Door #(s):  
118C

Provide each SGL door(s) with the following:

QT		DESCRIPTION	CATALOG NUMBER		FINISH	MFR
Y						
2	EA	HINGE	5BB1HW 4.5 X 4.5 NRP		630	IVE
1	EA	ELECTRIC HINGE	5BB1HW 4.5 X 4.5 CON TW8		✂ 630	IVE
1	EA	EU STOREROOM LOCK	MA881-24RXP DG CON 24VDC		✂ 626	FAL
1	EA	LOCK GUARD	LG10		630	IVE
1	EA	SURFACE CLOSER	SC71A SS		689	FAL
1	EA	GASKETING/WEATHERS TRIPPING	8150SBK PSA (HEAD & JAMB)		BK	ZER
1	EA	DOOR SWEEP	39A		A	ZER
1	EA	SADDLE THRESHOLD	1/2" HIGH X FULL JAMB DEPTH (OR PER SILL DETAILS)		A	ZER
1	EA	WIRE HARNESS (FROM DEVICE TO HINGE)	CON-XX(LENGTH TO SUIT)		✂	SCH
1	EA	POWER SUPPLY WIRE HARNESS	CON-6W		✂	SCH
1	EA	CREDENTIAL READER	BY SECURITY.		✂	
1	EA	DOOR POSITION SWITCH	BY SECURITY. (AS REQ'D)		✂	
1	EA	LOW VOLTAGE POWER	BY LOW VOLTAGE.		✂	

OPERATION:







DOOR IS NORMALLY LATCHED AND SECURED  
PRESENTING VALID CREDENTIAL TEMPORALLY RELEASES LEVER FOR ENTRY  
DOOR IS MONITORED THROUGH ACCESS CONTROL OR SECURITY SYSTEM  
DOOR IS SECURED UPON LOSS OF POWER TO THE LOCK  
FREE EGRESS AT ALL TIMES

Hardware Group No. 05

For use on Door #(s):

110                      123                      129B                      134                      136                      138

Provide each SGL door(s) with the following:

QT		DESCRIPTION	CATALOG NUMBER		FINISH	MFR
Y						
2	EA	HINGE	5BB1 4.5 X 4.5		652	IVE
1	EA	ELECTRIC HINGE	5BB1 4.5 X 4.5 CON TW8		↗ 652	IVE
1	EA	EU STOREROOM LOCK	MA881-24RXP DG CON 24VDC		↗ 626	FAL
1	EA	SURFACE CLOSER	SC71A RW/PA		689	FAL
1	EA	WALL STOP	WS406/407CVX		630	IVE
1	EA	GASKETING	488SBK PSA @ HEAD & JAMBS		BK	ZER
1	EA	WIRE HARNESS (FROM DEVICE TO HINGE)	CON-XX(LENGTH TO SUIT)		↗	SCH
1	EA	POWER SUPPLY WIRE HARNESS	CON-6W		↗	SCH
1	EA	CREDENTIAL READER	BY SECURITY.		↗	
1	EA	LOW VOLTAGE POWER	BY LOW VOLTAGE.		↗	

ELEC. LOCKSET IS SPECIFIED. VERIFY  
 PROVIDE PANIC DEVICE AND CHANGE DOOR SWINGING DIRECTION TO OUTWARD OF ELEC.  
 ROOM DOOR #123 IF REQUIRED PER CODE

OPERATION:







DOOR IS NORMALLY LATCHED AND SECURED  
 PRESENTING VALID CREDENTIAL TEMPORALLY RELEASES LEVER FOR ENTRY  
 DOOR IS MONITORED THROUGH ACCESS CONTROL OR SECURITY SYSTEM  
 DOOR IS SECURED UPON LOSS OF POWER TO THE LOCK  
 FREE EGRESS AT ALL TIMES

Hardware Group No.05.1

For use on Door #(s):

130                      131

Provide each SGL door(s) with the following:

QT		DESCRIPTION	CATALOG NUMBER		FINISH	MFR
Y						
2	EA	HINGE	5BB1 4.5 X 4.5		652	IVE
1	EA	ELECTRIC HINGE	5BB1 4.5 X 4.5 CON TW8		↗ 652	IVE
1	EA	EU STOREROOM LOCK	MA881-24RXP DG CON 24VDC		↗ 626	FAL
1	EA	OH STOP	450S		630	GLY
1	EA	SURFACE CLOSER	SC71A RW/PA		689	FAL
1	EA	GASKETING	488SBK PSA @ HEAD & JAMBS		BK	ZER
1	EA	WIRE HARNESS (FROM DEVICE TO HINGE)	CON-XX(LENGTH TO SUIT)		↗	SCH
1	EA	POWER SUPPLY WIRE HARNESS	CON-6W		↗	SCH
1	EA	CREDENTIAL READER	BY SECURITY.		↗	
1	EA	LOW VOLTAGE POWER	BY LOW VOLTAGE.		↗	

ELEC. LOCKSET IS SPECIFIED. VERIFY  
 PROVIDE PANIC DEVICE AND CHANGE DOOR SWINGING DIRECTION TO OUTWARD OF ELEC.  
 ROOM DOOR #123 IF REQUIRED PER CODE









OPERATION:

DOOR IS NORMALLY LATCHED AND SECURED  
 PRESENTING VALID CREDENTIAL TEMPORALLY RELEASES LEVER FOR ENTRY  
 DOOR IS MONITORED THROUGH ACCESS CONTROL OR SECURITY SYSTEM  
 DOOR IS SECURED UPON LOSS OF POWER TO THE LOCK  
 FREE EGRESS AT ALL TIMES

Hardware Group No. 06

For use on Door #(s):  
135B

Provide each SGL door(s) with the following:

QT		DESCRIPTION	CATALOG NUMBER		FINISH	MFR
Y						
2	EA	HINGE	5BB1HW 4.5 X 4.5 NRP		652	IVE
1	EA	ELECTRIC HINGE	5BB1HW 4.5 X 4.5 CON TW8		✓ 652	IVE
1	EA	STOREROOM LOCK	MA581P6 DG		626	FAL
1	EA	ELECTRIC STRIKE	6211 FSE 12/16/24/28 VAC/VDC (FINISH TO MATCH FRAME)		✓ 630	VON
1	EA	SURF. AUTO OPERATOR	4642 WMS 120 VAC		✓ 689	LCN
2	EA	VESTIBULE ACTUATOR, TOUCH	8310-855		✓	LCN
1	EA	KICK PLATE	8400 10" X 2" LDW B-CS		630	IVE
1	EA	GASKETING	488SBK PSA @ HEAD & JAMBS		BK	ZER
1	EA	AUTO DOOR BOTTOM	355AA		AA	ZER
1	EA	WIRE HARNESS (FROM DEVICE TO HINGE)	CON-XX(LENGTH TO SUIT)		✓	SCH
1	EA	POWER SUPPLY WIRE HARNESS	CON-6W		✓	SCH
1	EA	CREDENTIAL READER	BY SECURITY.		✓	
1	EA	DOOR POSITION SWITCH	BY SECURITY. (AS REQ'D)		✓	
1	EA	REMOTE RELEASE BUTTON	BY SECURITY. (AS REQ'D)		✓	
1	EA	LOW VOLTAGE POWER	BY LOW VOLTAGE.		✓	

FALCON MA LOCK IS UNAVAILABLE WITH LX SWITCH VERIFY

OPERATION:

DOOR IS NORMALLY LATCHED AND SECURED

PRESENTING VALID CREDENTIAL TEMPORARILY RELEASES STRIKE FOR ENTRY

EXTERIOR ACTUATOR IS CONTROLLED THROUGH ACCESS CONTROL SYSTEM; INTERIOR IS ALWAYS ACTIVE

DOOR IS SECURED UPON LOSS OF POWER TO THE STRIKE





FREE EGRESS AT ALL TIMES

Hardware Group No. 07

For use on Door #(s):

105	106	107	108	109A	116
132			145A	145B	

Provide each SGL door(s) with the following:

QT		DESCRIPTION	CATALOG NUMBER		FINISH	MFR
Y						
3	EA	HINGE	5BB1 4.5 X 4.5		652	IVE
1	EA	OFFICE LOCK	MA521P6 DG		626	FAL
1	EA	WALL STOP	WS406/407CVX		630	IVE
1	EA	GASKETING	488SBK PSA @ HEAD & JAMBS		BK	ZER







INSTALL CYLINDER AT BREAKROOM SIDE FOR DOOR 109A

Hardware Group No. 08

For use on Door #(s):

151

Provide each SGL door(s) with the following:





QT		DESCRIPTION	CATALOG NUMBER		FINISH	MFR
Y						
3	EA	HINGE	5BB1 4.5 X 4.5		652	IVE
1	EA	PASSAGE SET	MA101 DG		626	FAL
1	EA	SURFACE CLOSER- HOLD OPEN	SC71A SSHO		689	FAL
1	EA	KICK PLATE	8400 10" X 2" LDW B-CS		630	IVE
1	EA	GASKETING	488SBK PSA @ HEAD & JAMBS		BK	ZER
1	EA	AUTO DOOR BOTTOM	355AA		AA	ZER

VERIFY CLOSE WITH HOLD OPEN ARM

Hardware Group No. 09

For use on Door #(s):  
146







Provide each SGL door(s) with the following:

QT		DESCRIPTION	CATALOG NUMBER		FINISH	MFR
Y						
3	EA	HINGE	5BB1 4.5 X 4.5		652	IVE
1	EA	OFFICE LOCK	MA521P6 DG		626	FAL
1	EA	SURFACE CLOSER	SC71A RW/PA		689	FAL
1	EA	WALL STOP	WS406/407CVX		630	IVE
1	EA	GASKETING	488SBK PSA @ HEAD & JAMBS		BK	ZER

Hardware Group No. 10

For use on Door #(s):  
111                      114                      127                      128                      152

Provide each SGL door(s) with the following:







QT		DESCRIPTION	CATALOG NUMBER		FINISH	MFR
Y						
3	EA	HINGE	5BB1 4.5 X 4.5		630	IVE
1	EA	PRIVACY LOCK	MA301 OCCUPIED/VACANT DG		626	FAL
1	EA	SURFACE CLOSER	SC71A RW/PA		689	FAL
1	EA	KICK PLATE	8400 10" X 2" LDW B-CS		630	IVE
1	EA	WALL STOP	WS406/407CVX		630	IVE
1	EA	GASKETING	488SBK PSA @ HEAD & JAMBS		BK	ZER
1	EA	COAT AND HAT HOOK	507		626	IVE

Hardware Group No. 11

For use on Door #(s):

120                      121                      153

Provide each SGL door(s) with the following:





QT		DESCRIPTION	CATALOG NUMBER		FINISH	MFR
Y						
3	EA	HINGE	5BB1 4.5 X 4.5		630	IVE
1	EA	PASSAGE SET	MA101 DG		626	FAL
1	EA	SURFACE CLOSER- HOLD OPEN	SC71A HW/PA		689	FAL
1	EA	KICK PLATE	8400 10" X 2" LDW B-CS		630	IVE
1	EA	WALL STOP	WS406/407CVX		630	IVE
1	EA	GASKETING	488SBK PSA @ HEAD & JAMBS		BK	ZER

Hardware Group No. 12

For use on Door #(s):

149

Provide each SGL door(s) with the following:





QT		DESCRIPTION	CATALOG NUMBER		FINISH	MFR
Y						
3	EA	HINGE	5BB1 4.5 X 4.5		630	IVE
1	EA	PRIVACY LOCK	MA301 OCCUPIED/VACANT DG		626	FAL
1	EA	WALL STOP	WS406/407CVX		630	IVE
1	EA	GASKETING	488SBK PSA @ HEAD & JAMBS		BK	ZER
1	EA	COAT AND HAT HOOK	507		626	IVE

Hardware Group No. 13

For use on Door #(s):

155                      156                      157

Provide each SGL door(s) with the following:

QT		DESCRIPTION	CATALOG NUMBER		FINISH	MFR
Y						
3	EA	HINGE	5BB1 4.5 X 4.5		630	IVE
1	EA	PRIVACY LOCK	MA301 OCCUPIED/VACANT DG		626	FAL
1	EA	WALL STOP	WS406/407CVX		630	IVE
1	EA	COAT AND HAT HOOK	507		626	IVE
3	EA	SILENCER	SR64		GRY	IVE

PROVIDE OVERHEAD STOP IN LIEU OF WALL STOP WHERE WALL STOP CAN'T BE INSTALLED

Hardware Group No.14 **Not Used**





For use on Door #(s):

Hardware Group No. 15

For use on Door #(s):

139A                      139B

Provide each SGL door(s) with the following:







QT		DESCRIPTION	CATALOG NUMBER		FINISH	MFR
Y						
3	EA	HINGE	5BB1 4.5 X 4.5		652	IVE
1	EA	PASSAGE SET	MA101 DG		626	FAL
1	EA	WALL STOP	WS406/407CVX		630	IVE
1	EA	GASKETING	488SBK PSA @ HEAD & JAMBS		BK	ZER

Hardware Group No. 16

For use on Door #(s):

148A                      148B

Provide each SGL door(s) with the following:





QT		DESCRIPTION	CATALOG NUMBER		FINISH	MFR
Y						
3	EA	HINGE	5BB1HW 4.5 X 4.5		630	IVE
1	EA	PASSAGE SET	MA101 DG		626	FAL
1	EA	SURFACE CLOSER	SC71A RW/PA		689	FAL
1	EA	KICK PLATE	8400 10" X 2" LDW B-CS		630	IVE
1	EA	WALL STOP	WS406/407CVX		630	IVE
1	EA	GASKETING	488SBK PSA @ HEAD & JAMBS		BK	ZER
1	EA	AUTO DOOR BOTTOM	355AA		AA	ZER
1	EA	THRESHOLD	PER DETAILS		TBD	TBD

Hardware Group No. 17

For use on Door #(s):

109B                      115                      122                      154                      159

Provide each SGL door(s) with the following:





QT		DESCRIPTION	CATALOG NUMBER		FINISH	MFR
Y						
3	EA	HINGE	5BB1 4.5 X 4.5		652	IVE
1	EA	STOREROOM LOCK	MA581P6 DG		626	FAL
1	EA	WALL STOP	WS406/407CVX		630	IVE
3	EA	SILENCER	SR64		GRY	IVE

Hardware Group No. 18

For use on Door #(s):

112

Provide each SGL door(s) with the following:

QT		DESCRIPTION	CATALOG NUMBER		FINISH	MFR
Y						
3	EA	HINGE	5BB1 4.5 X 4.5		652	IVE
1	EA	STOREROOM LOCK	MA581P6 DG		626	FAL
1	EA	OH STOP	450S		630	GLY
3	EA	SILENCER	SR64		GRY	IVE





PROVIDE WALL STOP IN LIEU OF OVERHEAD STOP WHERE WALL STOP CAN BE INSTALLED

Hardware Group No. 19

For use on Door #(s):

118D 119

Provide each PR door(s) with the following:

QT		DESCRIPTION	CATALOG NUMBER		FINISH	MFR
Y						
6	EA	HINGE	5BB1 4.5 X 4.5		652	IVE
1	EA	MANUAL FLUSH BOLT	FB358		626	IVE
1	EA	STOREROOM LOCK	MA581P6 DG		626	FAL
2	EA	WALL STOP	WS406/407CVX		630	IVE
2	EA	SILENCER	SR64		GRY	IVE

OMIT WALL STOP WHERE IT CAN'T BE INSTALLED

Hardware Group No.20- Not Used







For use on Door #(s):

Hardware Group No. 21

For use on Door #(s):

147

Provide each SGL door(s) with the following:

QT		DESCRIPTION	CATALOG NUMBER		FINISH	MFR
Y						
3	EA	HINGE	5BB1 4.5 X 4.5		652	IVE
1	EA	CLASSROOM LOCK	MA561P6 DG		626	FAL
1	EA	SURFACE CLOSER	SC71A RW/PA		689	FAL
1	EA	KICK PLATE	8400 10" X 2" LDW B-CS		630	IVE
1	EA	WALL STOP	WS406/407CVX		630	IVE
1	EA	GASKETING	488SBK PSA @ HEAD & JAMBS		BK	ZER





VERIFY LOCK FUNCTION

Hardware Group No. 22

For use on Door #(s):

103

Provide each SGL door(s) with the following:







QT		DESCRIPTION	CATALOG NUMBER		FINISH	MFR
Y						
3	EA	HINGE	5BB1 4.5 X 4.5		652	IVE
1	EA	PASSAGE SET	MA101 DG		626	FAL
1	EA	WALL STOP	WS406/407CVX		630	IVE
3	EA	SILENCER	SR64		GRY	IVE

Hardware Group No. 23

For use on Door #(s):

118A 118B

Provide each PR door(s) with the following:







QT		DESCRIPTION	CATALOG NUMBER		FINISH	MFR
Y						
6	EA	HINGE	5BB1HW 4.5 X 4.5 NRP		652	IVE
1	EA	SVR-LBR PANIC HARDWARE-EXIT ONLY	25-V-EO-LBR		626	FAL
1	EA	SVR-LBR PANIC HARDWARE- CLASSROOM TRIM	25-V-L-LBR-DANE		626	FAL
2	EA	SURFACE CLOSER- HOLD OPEN	SC71A DSHO		689	FAL
1	EA	GASKETING	488SBK PSA @ HEAD & JAMBS		BK	ZER
1	EA	MEETING STILE	8217SBK PSA		BK	ZER
2	EA	AUTO DOOR BOTTOM	355AA		AA	ZER

PROVIDE FIRE EXIT HARDWARE AT FIRE RATED OPENING

Hardware Group No. 24

For use on Door #(s):  
143C

Provide each PR door(s) with the following:





QT		DESCRIPTION	CATALOG NUMBER		FINISH	MFR
Y						
6	EA	HINGE	5BB1HW 4.5 X 4.5		630	IVE
2	EA	PUSH PLATE	8200 4" X 16"		630	IVE
2	EA	PULL PLATE	8305 10" 4" X 16"		630	IVE
2	EA	SURFACE CLOSER	SC71A RW/PA		689	FAL
2	EA	KICK PLATE	8400 10" X 1" LDW B-CS		630	IVE
2	EA	WALL STOP	WS406/407CVX		630	IVE
2	EA	SILENCER	SR64		GRY	IVE

HARDWARE IS FOR NON-RATED OPENING. VERIFY HARDWARE FUNCTION

Hardware Group No. 25

For use on Door #(s):  
144





Provide each SGL door(s) with the following:

QT		DESCRIPTION	CATALOG NUMBER		FINISH	MFR
Y						
3	EA	HINGE	5BB1HW 4.5 X 4.5 NRP		652	IVE
1	EA	PANIC HARDWARE	25-R-L-DANE		626	FAL
1	EA	MORTISE CYLINDER/CORE	MATCH EXISTING. CONFIRM W/OWNER		626	
1	EA	SURFACE CLOSER	SC71A RW/PA		689	FAL
1	EA	WALL STOP	WS406/407CVX		630	IVE
1	EA	GASKETING	488SBK PSA @ HEAD & JAMBS		BK	ZER

Hardware Group No. 26

For use on Door #(s):  
104

Provide each SGL door(s) with the following:

QTY		DESCRIPTION	CATALOG NUMBER		FINISH	MFR
<u>3</u>	<u>EA</u>	<u>HINGE</u>	<u>5BB1 4.5 X 4.5</u>		<u>652</u>	<u>IVE</u>
<u>1</u>	<u>EA</u>	<u>STOREROOM LOCK</u>	<u>MA581P6 DG</u>		<u>626</u>	<u>FAL</u>
<u>1</u>	<u>EA</u>	<u>OH STOP</u>	<u>450S</u>		<u>630</u>	<u>GLY</u>
<u>3</u>	<u>EA</u>	<u>SILENCER</u>	<u>SR64</u>		<u>GRY</u>	<u>IVE</u>

Hardware Group No.27- Not Used

Hardware Group No. 28

For use on Door #(s):

124B            140B            140C            140D            141A            142A  
143A

Provide each RU door(s) with the following:

QT	DESCRIPTION	CATALOG NUMBER	FINISH	MFR
Y				
	EA    NOTE	HARDWARE BY		
		ROLLUP/SECTION DOOR MFG		

Hardware Group No.29- Not Used

Hardware Group No. A01

For use on Door #(s):

126A                      135A                      150A

Provide each SGL door(s) with the following:

QT		DESCRIPTION	CATALOG NUMBER		FINISH	MFR
Y						
1	EA	CONT. HINGE	112XY TWP CON		✓ 628	IVE
1	EA	PANIC HARDWARE-NIGHT LATCH	RX-MEL-24-R-NL-OP-CON 24 VDC		✓ 626	FAL
1	EA	RIM CYLINDER/CORE	MATCH EXISTING. VERIFY W/OWNER		626	
1	EA	90 DEG OFFSET PULL	8190HD 10" O (VERIFY TO MATCH EXISTING)		630	IVE
1	EA	OH STOP	100S ADJ		630	GLY
1	EA	SURF. AUTO OPERATOR	4642 WMS 120 VAC		✓ 689	LCN
1	EA	WEATHER RING	8310-801 (AS REQ'D)			LCN
1	EA	ACTUATOR, TOUCH	8310-853T		✓	LCN
1	EA	VESTIBULE ACTUATOR, TOUCH	8310-855		✓	LCN
1	EA	WEATHERSTRIPPING	BY AL/GL DOOR/FRAME MFG.			
1	SET	DOOR SWEEP	BY AL/GL DOOR/FRAME MFG.			
1	EA	THRESHOLD	BY AL/GL DOOR/FRAME MFG. (AS REQ'D)			
1	EA	WIRE HARNESS (FROM DEVICE TO HINGE)	CON-XX(LENGTH TO SUIT)		✓	SCH
1	EA	POWER SUPPLY WIRE HARNESS	CON-6W		✓	SCH
1	EA	CREDENTIAL READER	BY SECURITY.		✓	
1	EA	DOOR POSITION SWITCH	BY SECURITY. (AS REQ'D)		✓	
1	EA	LOW VOLTAGE POWER	BY LOW VOLTAGE.		✓	

HARDWARE IS FOR STOREFRONT SYSTEM WITH 1-3/4" THICK DOOR, PROVIDE IVES 027XY AT 2" THICK DOOR

FALCON EXIT DEVICE IS AVAILABLE WITH EITHER RX OR LX. VERIFY IF BOTH SWITCHES REQUIRED

VERIFY ACCESS CONTROL AT DOOR 135A. SECURITY DIDN'T CALL IT OUT

OPERATION:

DOOR IS NORMALLY LATCHED AND SECURED

DOOR MAY BE PROGRAMMED TO REMAIN UNLOCKED ON A SCHEDULE THROUGH ACCESS CONTROL SYSTEM

PRESENTING VALID CREDENTIAL TEMPORARILY RETRACTS LATCHBOLT FOR ENTRY WHEN DOOR IS LOCKED

DOOR IS MONITORED THROUGH ACCESS CONTROL OR SECURITY SYSTEM

DOOR IS SECURED UPON LOSS OF POWER TO THE DEVICE

FREE EGRESS AT ALL TIMES

Hardware Group No. A02

For use on Door #(s):  
101A

Provide each PR door(s) with the following:

QT		DESCRIPTION	CATALOG NUMBER		FINISH	MFR
Y						
2	EA	CONT. HINGE	112XY TWP CON		✓ 628	IVE
1	EA	ELEC PANIC HARDWARE	RX-MEL-24-C-C-LBR-LC-CON		✓ 626	FAL
			24 VDC			
1	EA	ELEC PANIC HARDWARE	RX-MEL-24-C-EO-LBR-CON 24		✓ 626	FAL
			VDC			
1	EA	MORTISE CYLINDER/CORE	MATCH EXISTING. CONFIRM W/OWNER		626	
2	EA	90 DEG OFFSET PULL	8190HD 10" O		630	IVE
			(VERIFY TO MATCH EXISTING)			
2	EA	OH STOP	100S ADJ		630	GLY
1	EA	DROP PLATE AND ACCESSORIES	PROVIDE AS NECESSARY		689	
1	EA	SURFACE CLOSER	SC71A HDPA		689	FAL
1	EA	SURF. AUTO OPERATOR	4642 WMS 120 VAC		✓ 689	LCN
1	EA	WEATHER RING	8310-801			LCN
			(AS REQ'D)			
1	EA	ACTUATOR, TOUCH	8310-853T		✓	LCN
1	EA	VESTIBULE ACTUATOR, TOUCH	8310-855		✓	LCN
1	EA	WEATHERSTRIPPING	BY AL/GL DOOR/FRAME MFG.			
1	EA	MEETING STILE	BY AL/GL DOOR/FRAME MFG.			
2	SET	DOOR SWEEP	BY AL/GL DOOR/FRAME MFG.			
1	EA	THRESHOLD	BY AL/GL DOOR/FRAME MFG. (AS REQ'D)			
2	EA	WIRE HARNESS (FROM DEVICE TO HINGE)	CON-XX(LENGTH TO SUIT)		✓	SCH
2	EA	POWER SUPPLY WIRE HARNESS	CON-6W		✓	SCH
2	EA	DOOR POSITION SWITCH	BY SECURITY. (AS REQ'D)		✓	
1	EA	CREDENTIAL READER	BY SECURITY.		✓	
1	EA	LOW VOLTAGE POWER	BY LOW VOLTAGE.		✓	

HARDWARE IS FOR STOREFRONT SYSTEM WITH 1-3/4" THICK DOOR, PROVIDE IVES 027XY AT 2" THICK DOOR

FALCON EXIT DEVICE IS AVAILABLE WITH EITHER RX OR LX. VERIFY IF BOTH SWITCHES REQUIRED







OPERATION:

DOOR IS NORMALLY LATCHED AND SECURED  
DOOR MAY BE PROGRAMMED TO REMAIN UNLOCKED ON A SCHEDULE THROUGH ACCESS CONTROL SYSTEM  
PRESENTING VALID CREDENTIAL TEMPORARILY RETRACTS LATCH BOLT FOR ENTRY WHEN DOOR IS LOCKED  
EXTERIOR ACTUATOR IS CONTROLLED THROUGH ACCESS CONTROL SYSTEM; INTERIOR IS ALWAYS ACTIVE  
DOOR IS MONITORED THROUGH ACCESS CONTROL OR SECURITY SYSTEM  
DOOR IS SECURED UPON LOSS OF POWER TO THE DEVICE  
FREE EGRESS AT ALL TIMES

Hardware Group No. A03

For use on Door #(s):  
101B

Provide each PR door(s) with the following:

QT		DESCRIPTION	CATALOG NUMBER		FINISH	MFR
Y						
2	EA	CONT. HINGE	112XY		628	IVE
2	EA	DUMMY PUSH BAR	250DT		626	FAL
2	EA	90 DEG OFFSET PULL	8190HD 10" O (VERIFY TO MATCH EXISTING)		630	IVE
2	EA	OH STOP	100S ADJ		630	GLY
1	EA	DROP PLATE AND ACCESSORIES	PROVIDE AS NECESSARY		689	
1	EA	SURFACE CLOSER	SC71A HDPA		689	FAL
1	EA	SURF. AUTO OPERATOR	4642 WMS 120 VAC		⚡ 689	LCN
1	EA	ACTUATOR, TOUCH	8310-853T		⚡	LCN
1	EA	WEATHERSTRIPPING	BY AL/GL DOOR/FRAME MFG.			
1	EA	MEETING STILE	BY AL/GL DOOR/FRAME MFG.			
1	EA	THRESHOLD	BY AL/GL DOOR/FRAME MFG. (AS REQ'D)			

REFERENCE EXTERIOR DOOR FOR VESTIBULE ACTUATOR  
HARDWARE IS FOR STOREFRONT SYSTEM WITH 1-3/4" THICK DOOR, PROVIDE IVES 027XY AT 2" THICK DOOR

OPERATION:





DOOR IS NORMALLY LATCHED AND SECURED  
DOOR MAY BE PROGRAMMED TO REMAIN UNLOCKED ON A SCHEDULE THROUGH ACCESS CONTROL SYSTEM  
PRESENTING VALID CREDENTIAL TEMPORARILY RETRACTS LATCH BOLT FOR ENTRY WHEN DOOR IS LOCKED  
EXTERIOR ACTUATOR IS CONTROLLED THROUGH ACCESS CONTROL SYSTEM; INTERIOR IS ALWAYS ACTIVE  
DOOR IS MONITORED THROUGH ACCESS CONTROL OR SECURITY SYSTEM  
DOOR IS SECURED UPON LOSS OF POWER TO THE DEVICE  
FREE EGRESS AT ALL TIMES

Hardware Group No. A04

For use on Door #(s):

126B                      150B

Provide each SGL door(s) with the following:

QT		DESCRIPTION	CATALOG NUMBER		FINISH	MFR
Y						
1	EA	CONT. HINGE	112XY		628	IVE
1	EA	DUMMY PUSH BAR	250DT		626	FAL
1	EA	90 DEG OFFSET PULL	8190HD 10" O		630	IVE
			(VERIFY TO MATCH EXISTING)			
1	EA	OH STOP	100S ADJ		630	GLY
1	EA	SURF. AUTO OPERATOR	4642 WMS 120 VAC		⚡ 689	LCN
1	EA	ACTUATOR, TOUCH	8310-853T		⚡	LCN
1	EA	WEATHERSTRIPPING	BY AL/GL DOOR/FRAME MFG.			
1	EA	THRESHOLD	BY AL/GL DOOR/FRAME MFG. (AS REQ'D)			

REFERENCE EXTERIOR DOOR FOR VESTIBULE ACTUATOR

HARDWARE IS FOR STOREFRONT SYSTEM WITH 1-3/4" THICK DOOR, PROVIDE IVES 027XY AT 2" THICK DOOR

OPERATION:

ACTUATORS ACTIVATE OPERATOR

FREE EGRESS AT ALL TIMES

SECTION 08 88 53  
BULLET RESISTANT GLAZING – LAMINATED POLYCARBONATE

PART 1 GENERAL

1.1 SUMMARY

- A. Section Includes:
  - 1. Bullet resistant laminated polycarbonate all poly security glass.
- B. Related Requirements:
  - 1. Section 01 33 00 – Submittal Procedures.

1.2 REFERENCE STANDARDS

- A. Underwriters Laboratory (UL):
  - 1. UL 752 – Standard for Bullet Resisting Equipment.
- B. ASTM International (ASTM):
  - 1. ASTM C1172 - Standard Specification for Laminated Architectural Flat Glass.

1.3 ACTION SUBMITTALS

- A. Product Data: Including manufacturer recommended installation instructions.
- B. Shop Drawings: Elevations, sections, details, attachment to other work.
- C. Samples: For each exposed glazing type.

1.4 INFORMATION SUBMITTALS

- A. Product Test Reports: Indicating compliance with requirement.
- B. Warranty: Sample of warranty.

1.5 CLOSEOUT SUBMITTALS

- A. Maintenance data.

1.6 DELIVERY, STORAGE, AND HANDLING

- A. Deliver materials to project site with manufacturer's UL Listed Labels intact and legible. Handle materials with care to prevent damage. Store materials inside and under cover, stack flat and off floor. Project conditions (temperature, humidity, and ventilation) within maximum limit recommendations provided by manufacturer. Do not install products stored in conditions outside manufacturer's recommended limits.

## 1.7 WARRANTY

- A. Workmanship Warranty: Warrant all materials against defects for 1 year for date of receipt at project site. Provide certificates of manufacturer's standard limited warranty with closeout documents.
- B. Finish Warranty: Manufacturer's warranty against deterioration of factory finishes for 1 year from date of Substantial Completion.

## PART 2 PRODUCTS

### 2.1 Manufactured Units:

- A. Basis of Design:
  - 1. Subject to compliance with requirements, provide products by following:
    - a. Total Security Solutions, Inc., 935 Garden Lane, Fowlerville, MI 48836, 8866 734-6277. Attn: Sales Department, sales@tssbulletproof.com. Web: www.tssbulletproof.com.
  - 2. Subject to compliance with requirements, manufacturers of products of equivalent design may be acceptable if approved by Architect.

### 2.2 BULLET RESISTANT ALL GLASS GLAZING

- A. Through design, manufacturing techniques, and material application, construct TSS Bullet Resistant Polycarbonate Laminated All Poly glazing of polycarbonate core with additional 1/8-inch polycarbonate layers on each side of glazing.
- B. UL Standard 752 rating: Level 3.
- C. Glass Thickness: Ranging from 3/4-inch to 1-1/4-inch thick.
- D. Install glass in 4-1/2-inch aluminum storefront framing.

### 2.3 FABRICATION

- A. Tolerances: All joints and connections to be tight, providing hairline joints and true alignment of adjacent members.

### 2.4 GLAZING

- A. As shown on Drawings.
- B. Product: Meet UL Standard 752 rating level 3.
  - 1. TSS Polycarbonate LP: All Poly 1250 – Level 3, light transmission of 77 percent with 1-1/4-inch thickness.

- C. Glazing Gaskets:
  - 1. Interior: Closed cell neoprene.

## PART 3 EXECUTION

### 3.1 PREPARATION

- A. Prior to beginning installation:
  - 1. Verify areas are prepared as required by Contract Documents and Drawings.
  - 2. Verify Shop Drawings are approved.
- B. Notify Architect of any unsatisfactory preparation that is responsibility of others.
- C. Clean and prepare all surfaces per manufacturer's recommendations as required for achieving best results of substrate under project conditions.
- D. Do not begin installation of material until all unsatisfactory conditions have been resolved and approved by Architect.

### 3.2 INSTALLATION

- A. Do not begin installation until areas are verified and surfaces properly prepared in accordance with Drawings.
- B. Install in accordance with manufacturer's instructions and UL 752. Set all equipment plumb.
- C. Apply sealant in accordance with manufacturer's recommendations as indicated in installation instructions.
- D. Remove excess sealant and leave exposed surfaces clean and smooth.

### 3.3 PROTECTION

- A. Clean and protect material from damage during ongoing construction operations. If damage occurs, remove and replace as required to provide voice ports in their original, undamaged condition.
- B. Inspection and Cleaning: Verify installation is complete and complies with manufacturer's requirements.
- C. Provide final cleaning of product and accessories, removing excess sealant, labels, and protective covers.
- D. Touch-up, repair, or replace damaged products prior to Substantial Completion.

END OF SECTION

SECTION 09 93 00  
STAINING AND TRANSPARENT FINISHING

PART 1 GENERAL

1.1 SUMMARY

- A. Section Includes:
  - 1. Surface preparation and application of transparent and semi-transparent stain and finish systems on interior and exterior wood substrates.
- B. Related Requirements:
  - 1. Section 06 10 00 – Rough Carpentry.

1.2 DEFINITIONS

- A. Transparent Finish: A penetrating oil-based wood finish that allows full visibility of wood grain and texture. Contains transparent iron oxide pigments for UV protection without obscuring natural wood appearance.
- B. Semi-Transparent Stain: A lightly pigmented finish that modifies wood color while allowing grain pattern to remain visible.
- C. Penetrating Finish: Finish that saturates wood rather than forming a surface film; not subject to peeling, flaking, or cracking.

1.3 SUBMITTALS

- A. Product Data: For each product specified. Include manufacturer's technical data sheets, product descriptions, VOC content, application instructions, and surface preparation requirements.
- B. Samples: Minimum 2 samples, 6-inch-by-8-inch minimum, of each specified color on actual wood species to be used. Allow 7 days for initial curing before reviewing.

1.4 QUALITY ASSURANCE

- A. Manufacturer Qualifications: Company with minimum 10 years of experience manufacturing penetrating wood stain and finish products.
- B. Applicator Qualifications: Firm with minimum 3 years documented experience applying penetrating wood stain systems of similar scope and conditions.
- C. Single-Source Responsibility: Provide stain, cleaner, brightener, and related products from same manufacturer.

## 1.5 DELIVERY, STORAGE, AND HANDLING

- A. Deliver materials in manufacturer's original, unopened containers with labels intact.
- B. Store products in tightly closed containers protected from freezing. Maintain storage temperatures between 40 degrees Fahrenheit and 90 degrees Fahrenheit.
- C. Keep away from heat, sparks, and open flames. Provide ventilation in storage areas.
- D. Dispose of cleaning materials and empty containers in accordance with applicable local, state, and federal regulations.

## 1.6 PROJECT CONDITIONS

- A. Environmental Conditions: Do not apply finish when ambient or substrate surface temperature is below 50 degrees Fahrenheit or above 90 degrees Fahrenheit.
- B. Do not apply to wet wood, or if rain, snow, or dew is expected within 24–48 hours of application.
- C. Do not apply in direct sunlight on hot days. If wood surface is hot to the touch, delay application.
- D. Humidity: Relative humidity not to exceed 85 percent during application and initial cure.

## 1.7 WARRANTY

- A. Manufacturer's Warranty: Submit manufacturer's standard warranty against defects in materials.
- B. Applicator Warranty: 1-year warranty against defects in workmanship, including improper preparation and application.

## PART 2 PRODUCTS

### 2.1 MANUFACTURERS

- A. Basis of Design: Messmer's Natural Wood Finishes; PO Box 8, West Jordan, UT 84084; (800) 731-3669; [www.messmers.com](http://www.messmers.com).
- B. Substitutions: Permitted with prior written approval of Architect.

## 2.2 MATERIALS – SURFACE PREPARATION

- A. Wood & Deck Cleaner (Part A): Messmer's WD Wood & Deck Cleaner (Part A), or approved equal. For cleaning gray, dirty, or mildewed wood prior to stain application.

## 2.3 MATERIALS – FINISH SYSTEMS

- A. Exterior and Interior Wood Transparent Finish – Standard Woods (cedar, pine, redwood, pressure-treated):
  1. Product: Messmer's UV Plus Exterior Wood Stain and Oil Finish. Natural.
  2. Type: Oil-based, penetrating, non-film-forming.
  3. Coverage: 250–400 square feet per gallon, depending on wood texture and porosity.

## 2.4 PERFORMANCE REQUIREMENTS

- A. UV Resistance: Product shall provide demonstrated resistance to UV degradation when applied per manufacturer's instructions.
- B. Film Formation: Product shall not form a surface film; shall not be subject to peeling or flaking when properly applied.
- C. Mildew Resistance: Product shall contain fungicide additives to inhibit mildew and algae staining.
- D. Recoat-ability: Recoat-able product without stripping or sanding following cleaning and brightening per manufacturer's instructions.

## PART 3 EXECUTION

### 3.1 EXAMINATION

- A. Inspect substrates for conditions that would adversely affect performance of finish system.
- B. Verify wood is free from moisture, grease, oil, wax, sealers, and other contaminants that would impede penetration.
- C. Do not begin application until unsatisfactory conditions have been corrected.

### 3.2 PREPARATION

- A. General: Clean all wood surfaces prior to application in accordance with manufacturer's written instructions.

- B. New Wood:
  - 1. Apply Messmer's WD Cleaner (Part A) to remove dirt, grease, and surface contaminants per manufacturer's dilution and dwell-time instructions.
  - 2. Rinse thoroughly and allow wood to dry completely: minimum 24–48 hours before applying finish.
  - 3. Pre-finish ceiling cedar tongue and groove outside prior to installation, if possible.
- C. Protect adjacent surfaces, glass, metal, masonry, and landscaping from finish products before application.

### 3.3 APPLICATION

- A. Mix: Stir product thoroughly before use. Ensure all settled pigment is evenly incorporated. Intermix all containers (box) before use.
- B. Number of Coats: Apply one coat. UV Plus is a one-coat application system when applied per manufacturer's instructions.
- C. Method: Apply by brush, roller, or airless sprayer. Work with the wood grain. On smooth surfaces, back-brush sprayed material to ensure penetration.
- D. Excess Material: Remove excess product from surface within 30 minutes of application. Failure to remove excess will result in tacky, shiny surface areas. Do not allow product to pond or puddle.
- E. Surface Temperature: Apply only when substrate surface temperature is between 50 degrees Fahrenheit and 90 degrees Fahrenheit and wood surface is not hot to touch.

### 3.4 FIELD QUALITY CONTROL

- A. Check finished surfaces for uniform color, complete coverage, and absence of tacky or shiny areas before Owner acceptance.

### 3.5 CLEANING

- A. Remove finish products from surfaces not intended to receive finish.
- B. Clean tools and equipment with mineral spirits or paint thinner.
- C. Dispose of all cleaning materials, oily rags, and empty containers in accordance with local, state, and federal regulations. Oily rags are a spontaneous combustion hazard; spread flat to dry or store submerged in water before disposal.

### 3.6 PROTECTION

- A. Protect finished work from damage and staining until Owner acceptance.
- B. Do not allow foot or vehicle traffic on finished deck surfaces for a minimum of 48 hours after application.

END OF SECTION

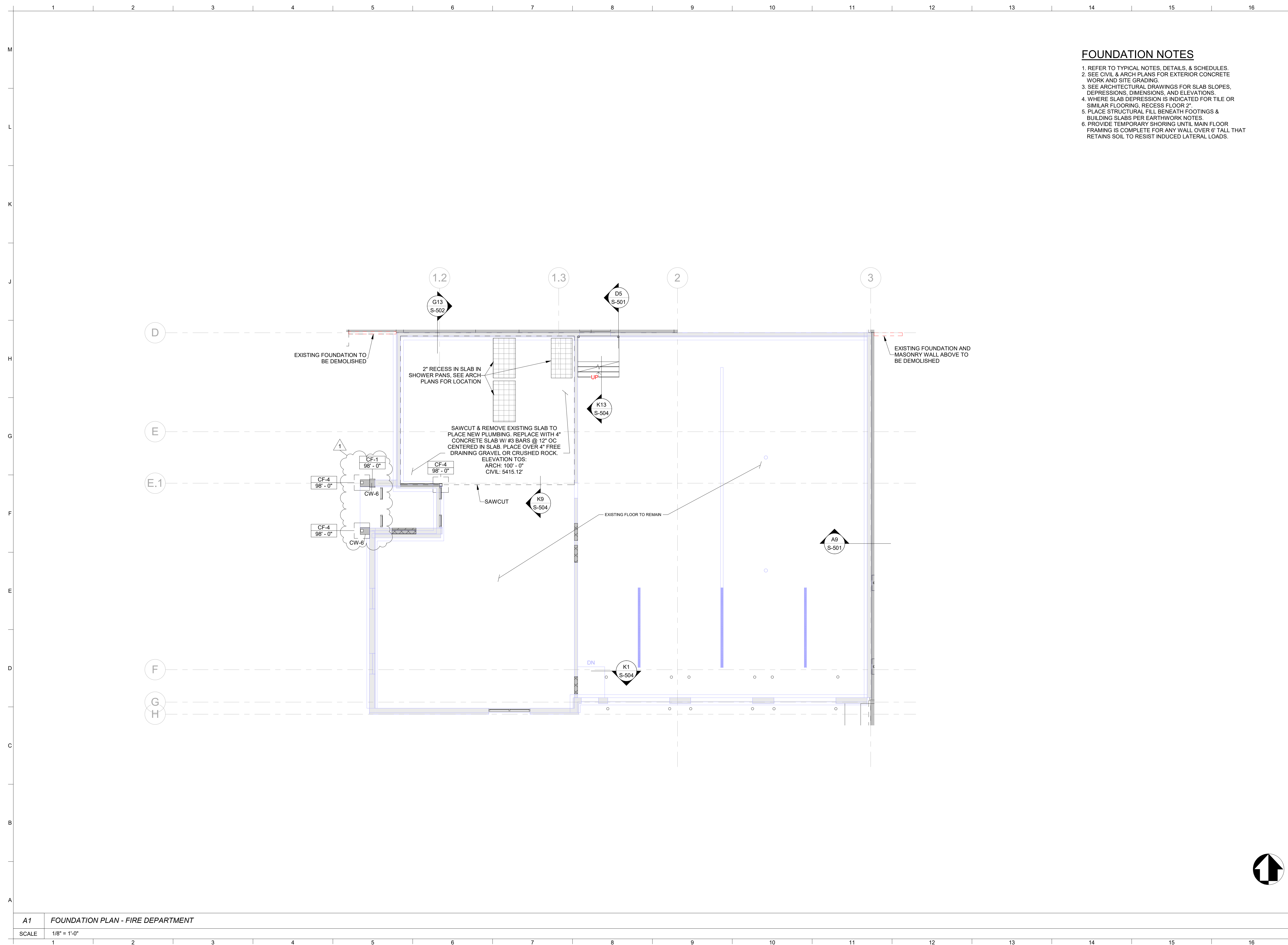

**FOUNDATION NOTES**

1. REFER TO TYPICAL NOTES, DETAILS, & SCHEDULES.
2. SEE CIVIL & ARCH PLANS FOR EXTERIOR CONCRETE WORK AND SITE GRADING.
3. SEE ARCHITECTURAL DRAWINGS FOR SLAB SLOPES, DEPRESSIONS, DIMENSIONS, AND ELEVATIONS.
4. WHERE SLAB DEPRESSION IS INDICATED FOR TILE OR SIMILAR FLOORING, RECESS FLOOR 2".
5. PLACE STRUCTURAL FILL BENEATH FOOTINGS & BUILDING SLABS PER EARTHWORK NOTES.
6. PROVIDE TEMPORARY SHORING UNTIL MAIN FLOOR FRAMING IS COMPLETE FOR ANY WALL OVER 6' TALL THAT RETAINS SOIL TO RESIST INDUCED LATERAL LOADS.

WELLINGTON CITY

ADMINISTRATION AND PUBLIC SAFETY BLDG

JDE No.2509-014

SUBMITTAL

FOR BIDDING ONLY

NO.	DATE	DESCRIPTION
1	05/22/26	ADDENDUM NO.1

STAMP



5/12/2026

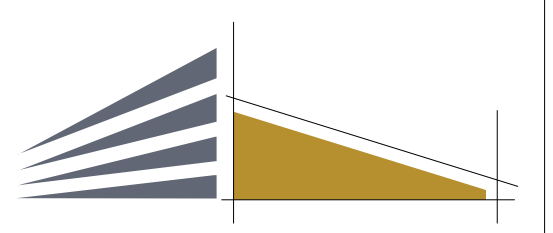

campbell architecture  
A J&D COMPANY  
campbelldesign.us | 435.628.5969

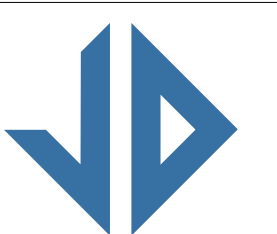

Jones & DeMille  
Engineering  
jonesanddemille.com | 800.748.5275

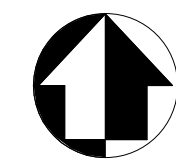

FOUNDATION PLAN - FIRE DEPARTMENT

S-103

A1	FOUNDATION PLAN - FIRE DEPARTMENT
SCALE	1/8" = 1'-0"

File Path: \\adsesd\docs\2509-014 Wellington City Office\2509-014 Wellington City Office.rvt

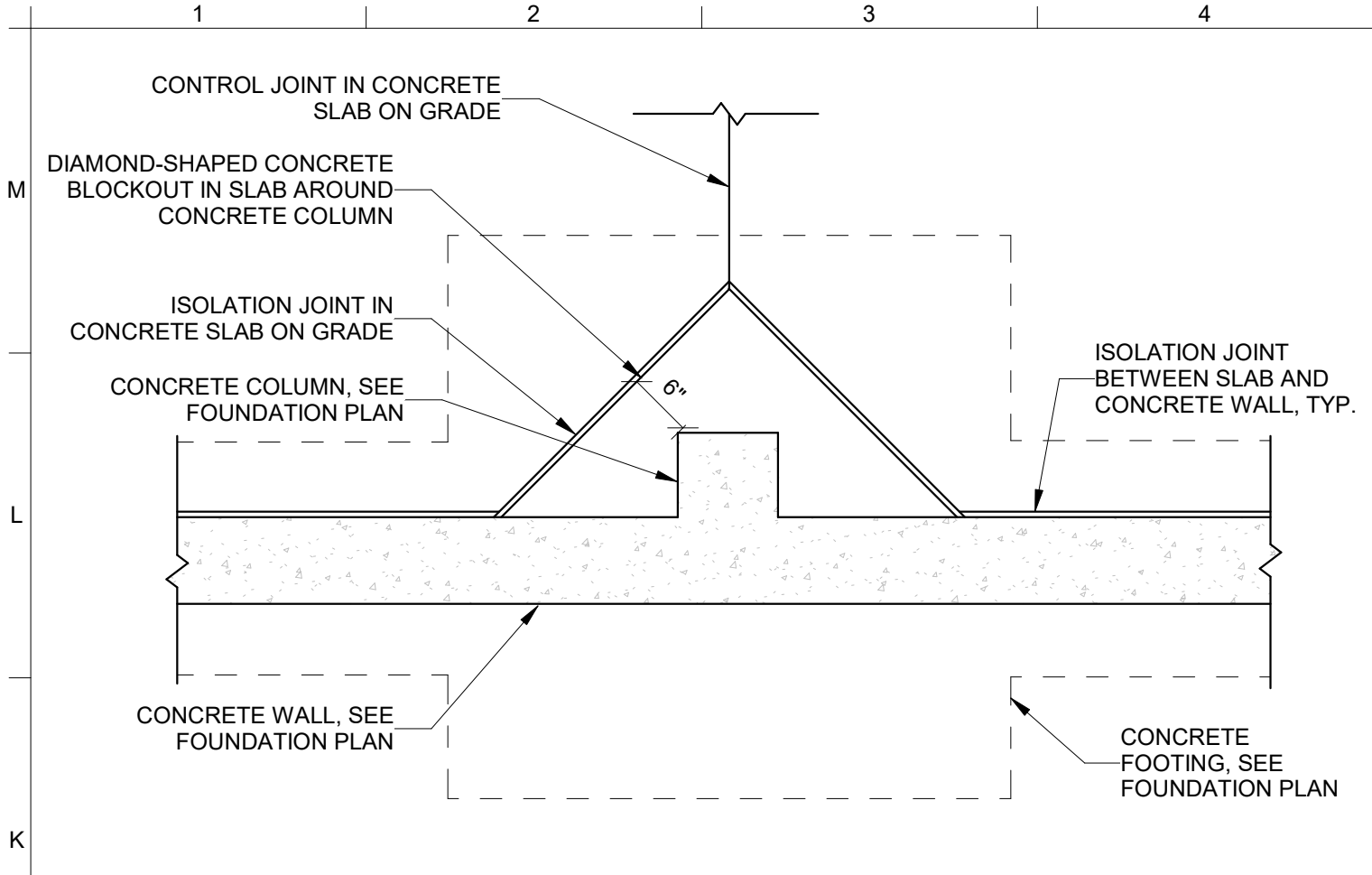

**K1** BLOCKOUT IN CONCRETE SLAB AROUND CONCRETE COLUMN  
SCALE NTS

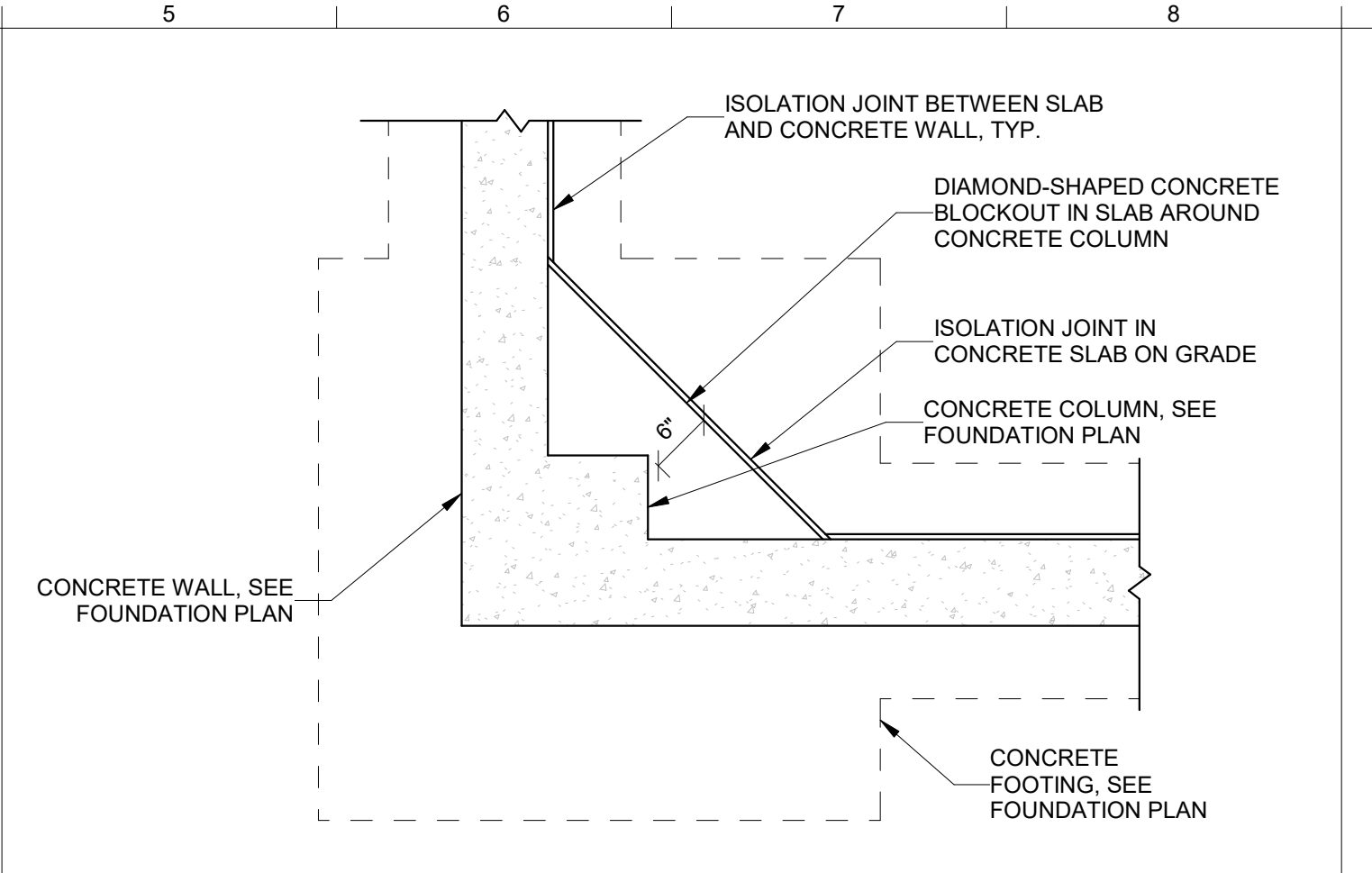

**K5** BLOCKOUT IN CONCRETE SLAB AROUND CONCRETE COLUMN  
SCALE NTS

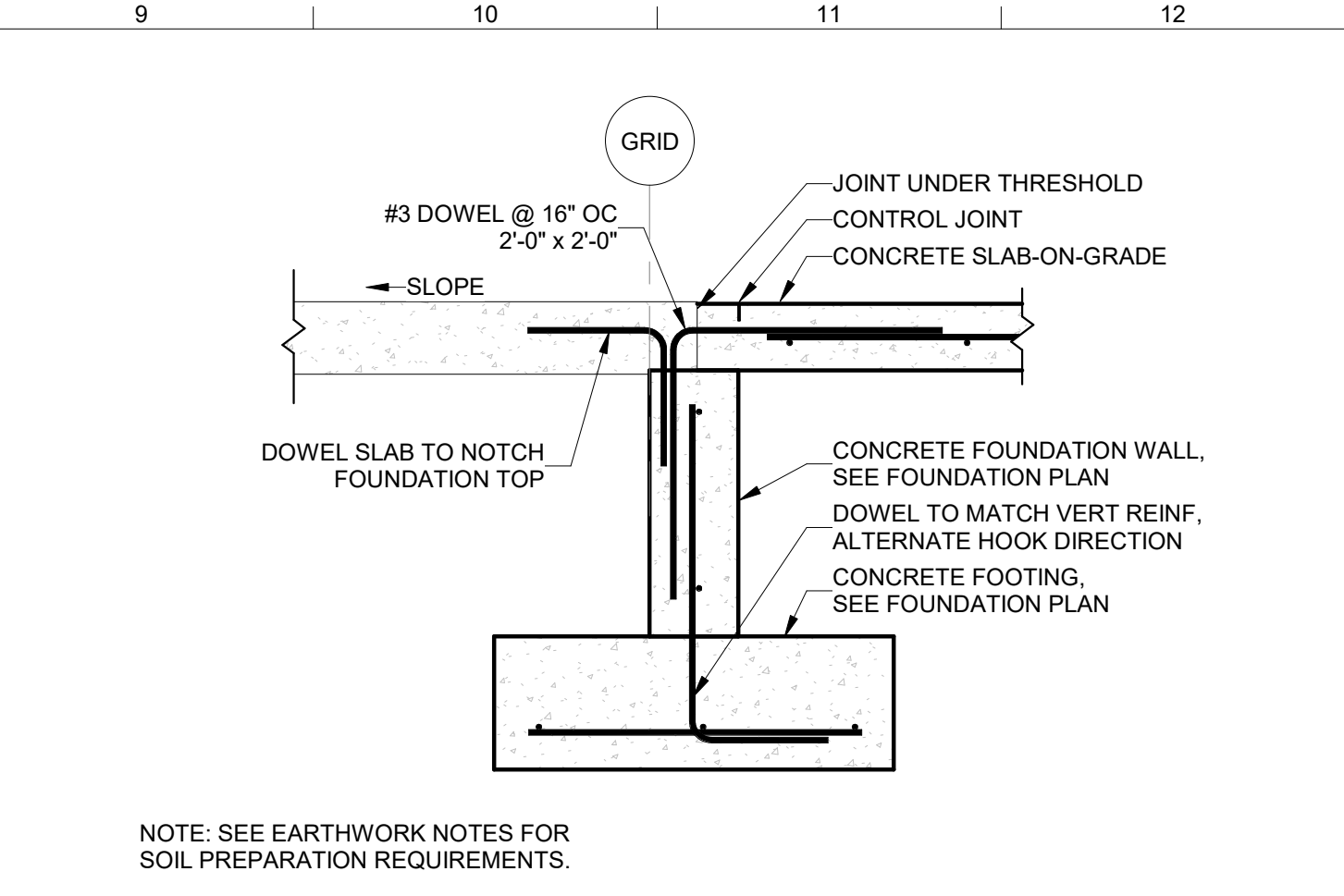

**K9** CONCRETE SLAB OVER FOUNDATION WALL @ DOOR OPENINGS  
SCALE NTS

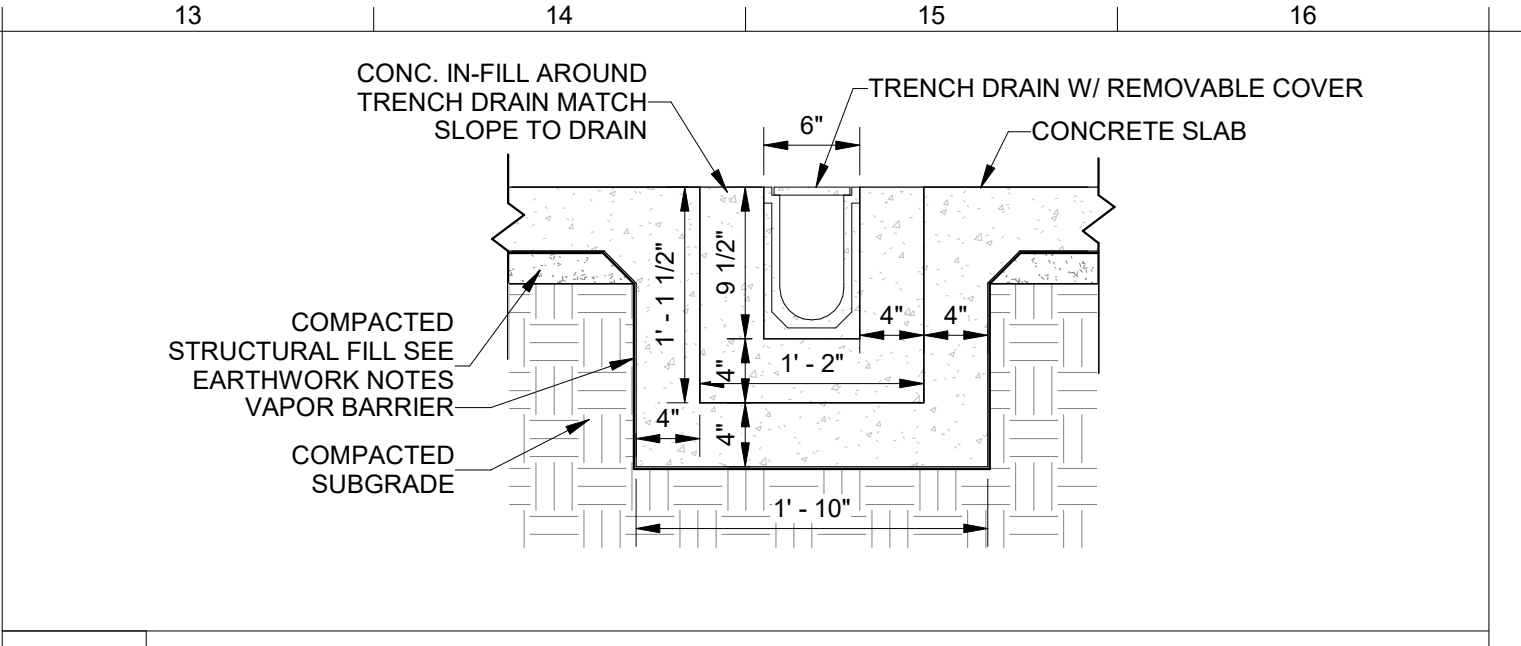

**K13** TRENCH DRAIN  
SCALE NTS

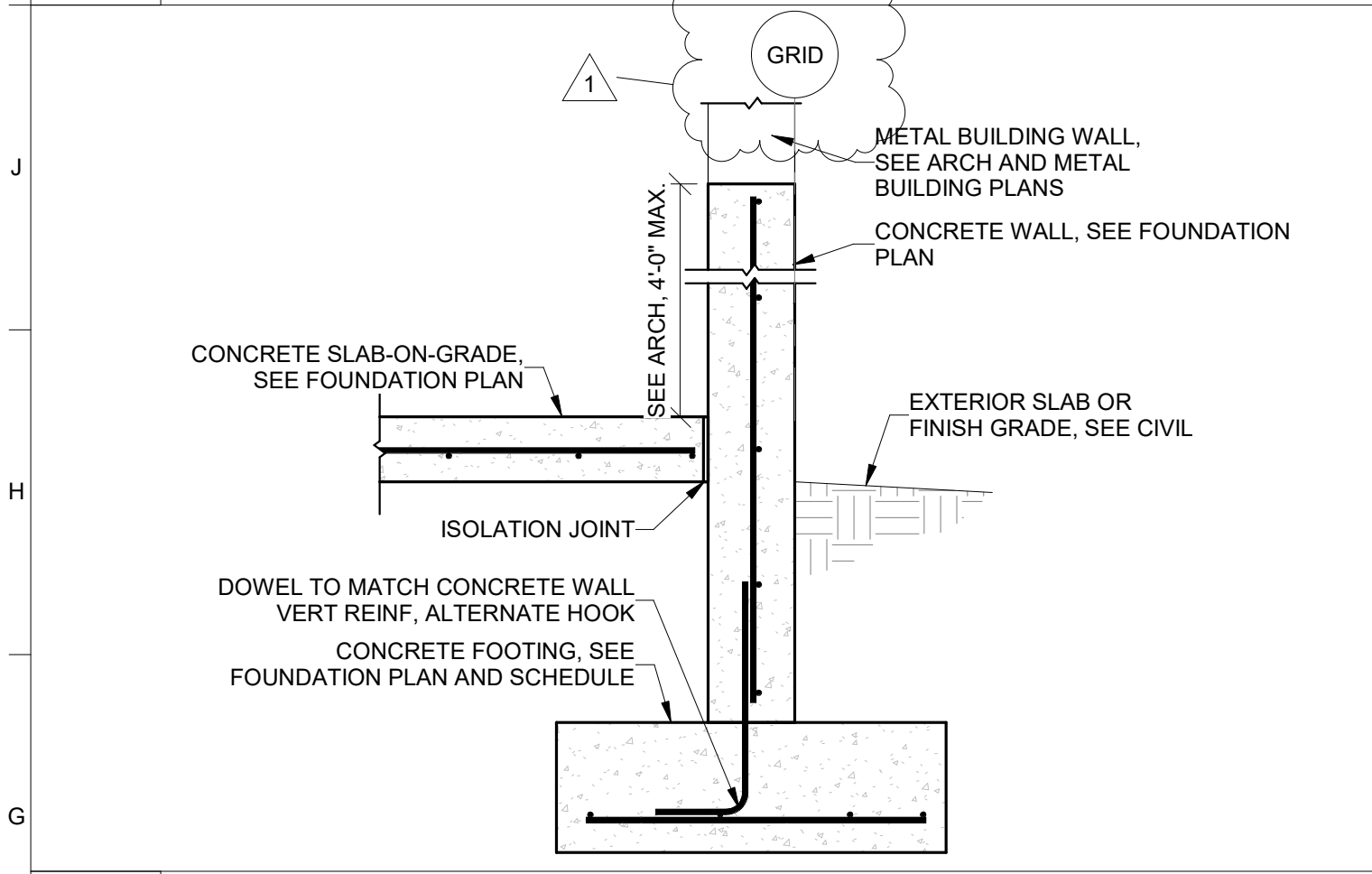

**G1** CONCRETE WALL ON CONCRETE FOUNDATION WALL  
SCALE NTS

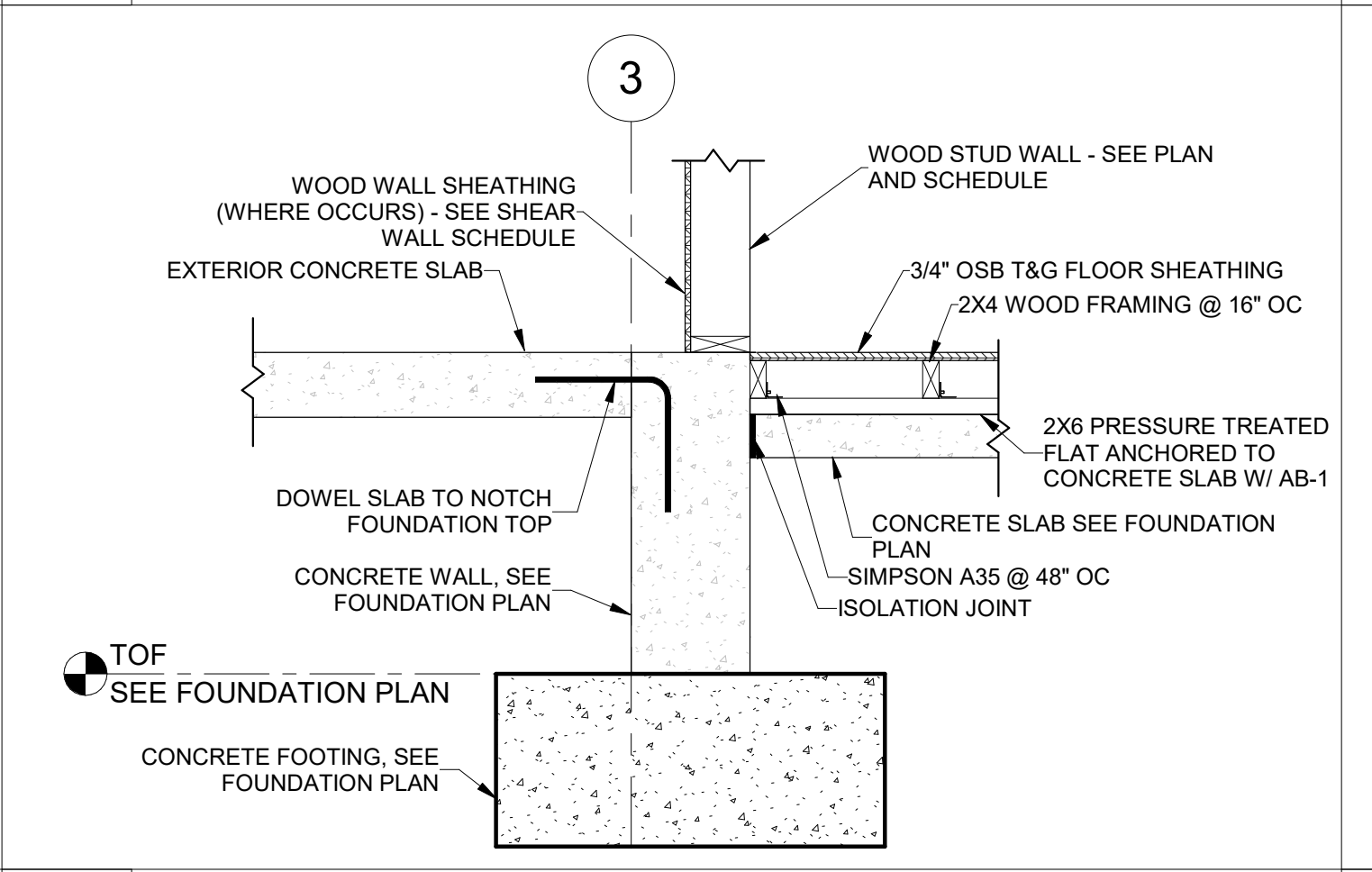

**G5** STRUCTURAL DETAIL  
SCALE NTS

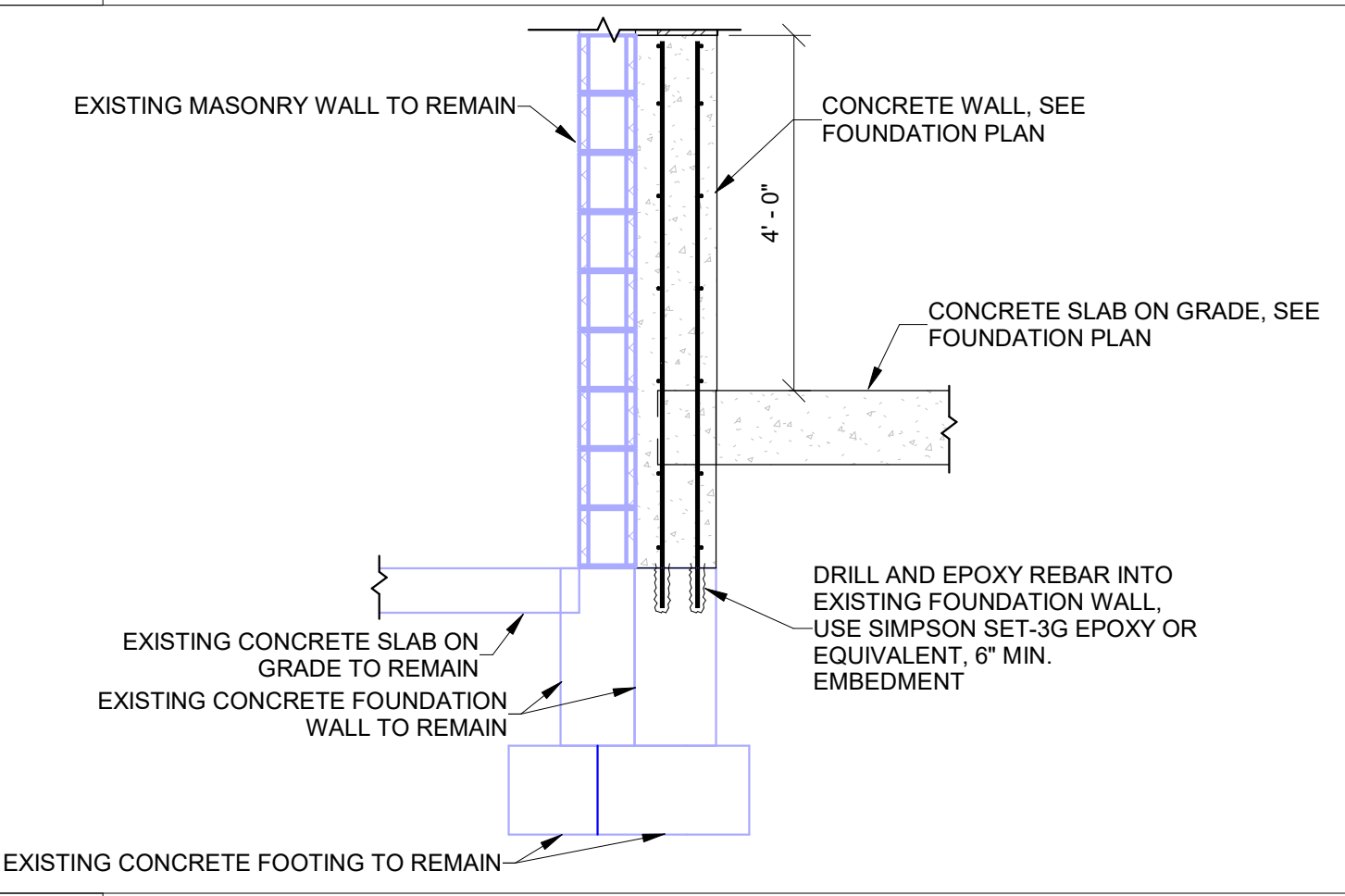

**G9** METAL BUILDING WALL NEXT TO EXISTING MASONRY WALL  
SCALE NTS

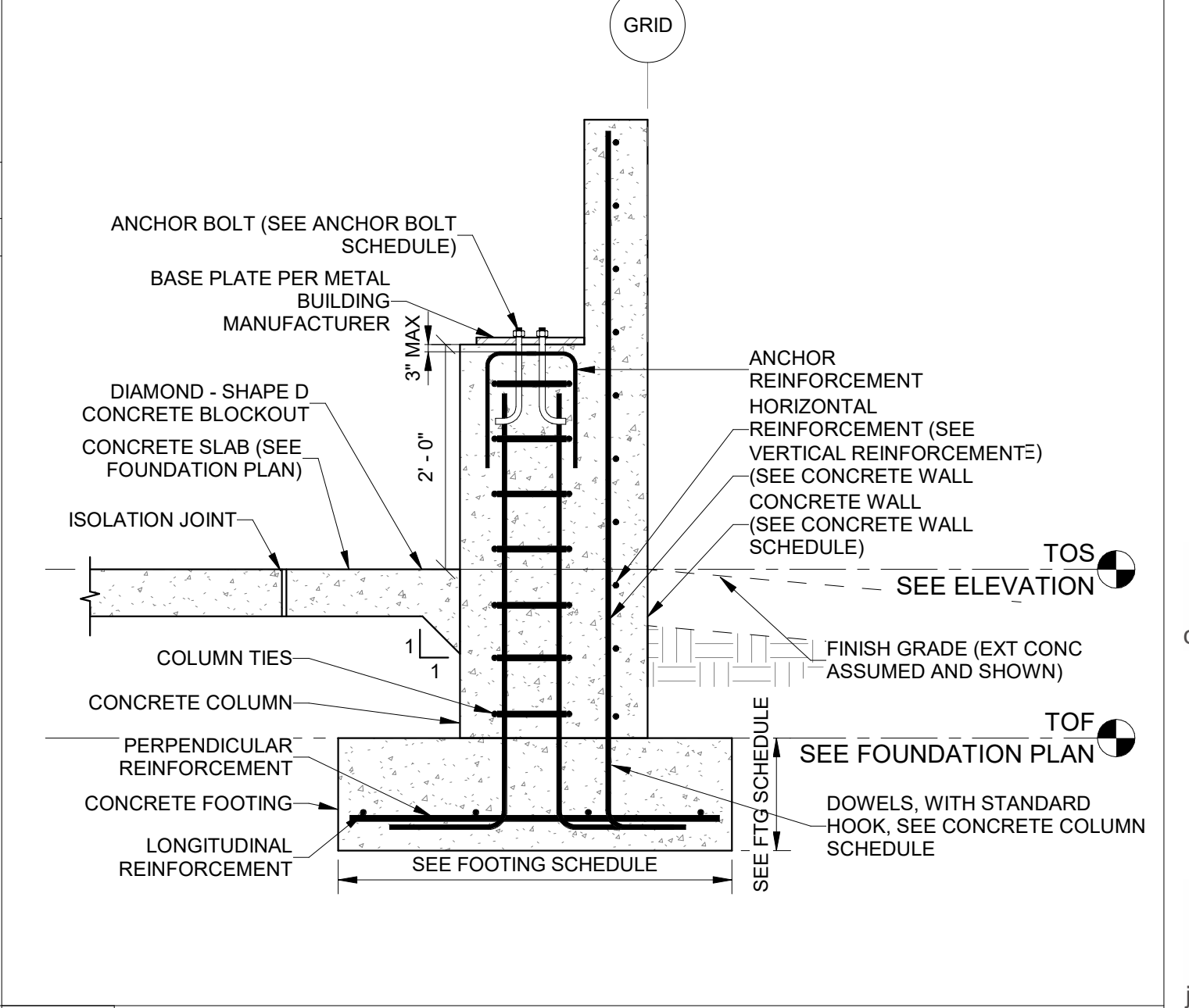

**G13** CONCRETE COLUMN AGAINST WALL WITH ANCHOR REINFORCEMENT (RAISED)  
SCALE NTS

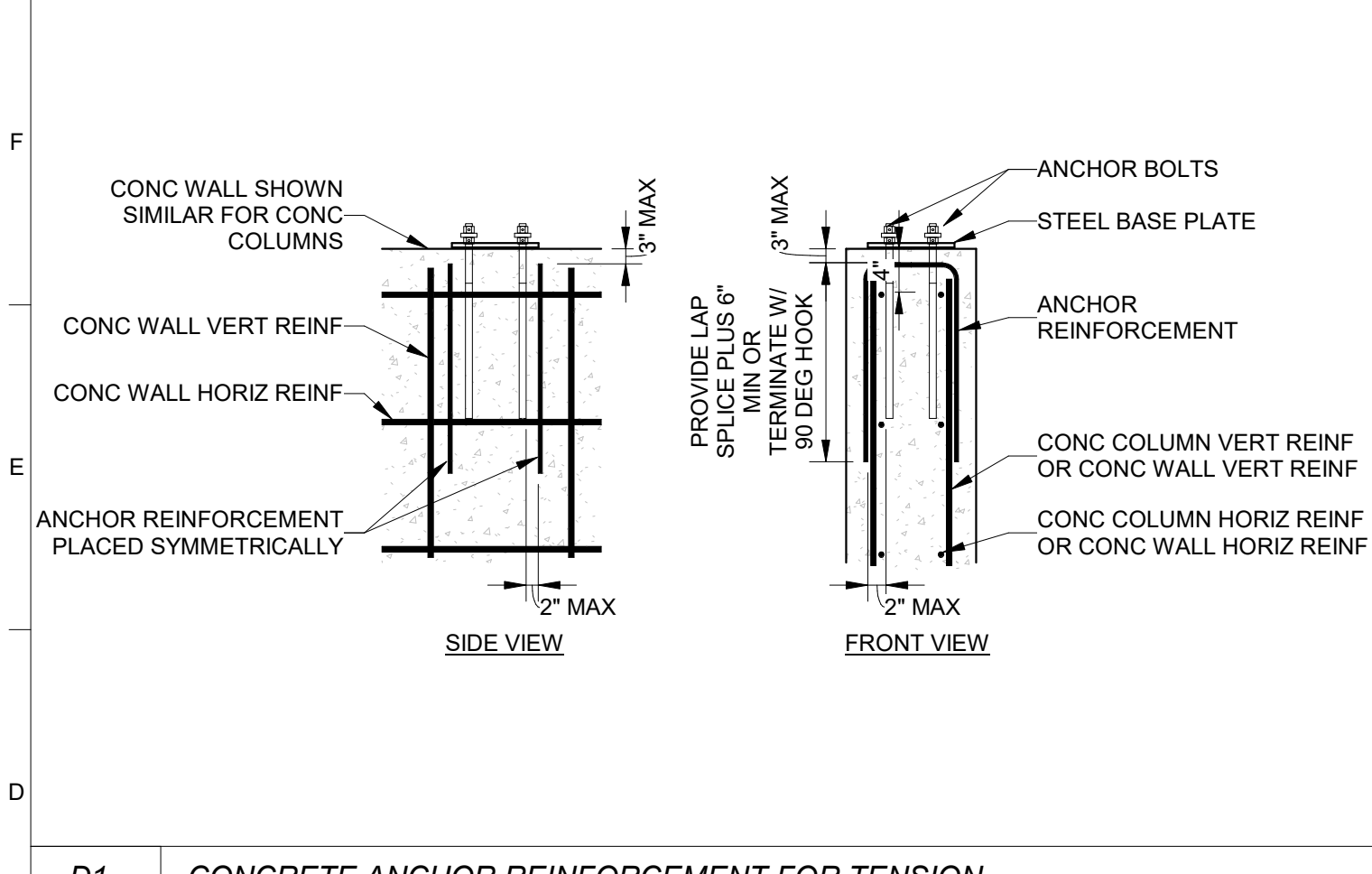

**D1** CONCRETE ANCHOR REINFORCEMENT FOR TENSION  
SCALE NTS

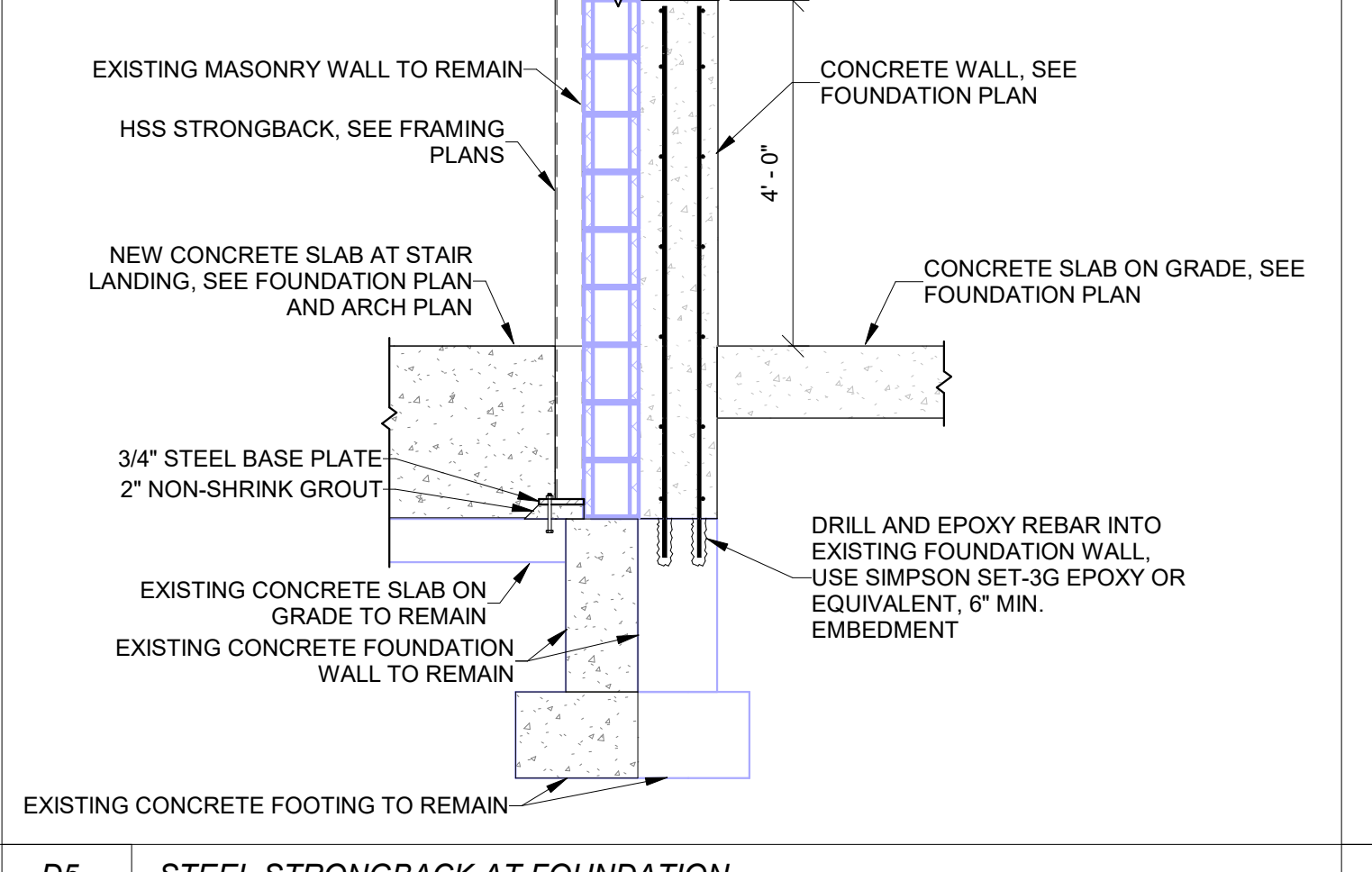

**D5** STEEL STRONGBACK AT FOUNDATION  
SCALE NTS

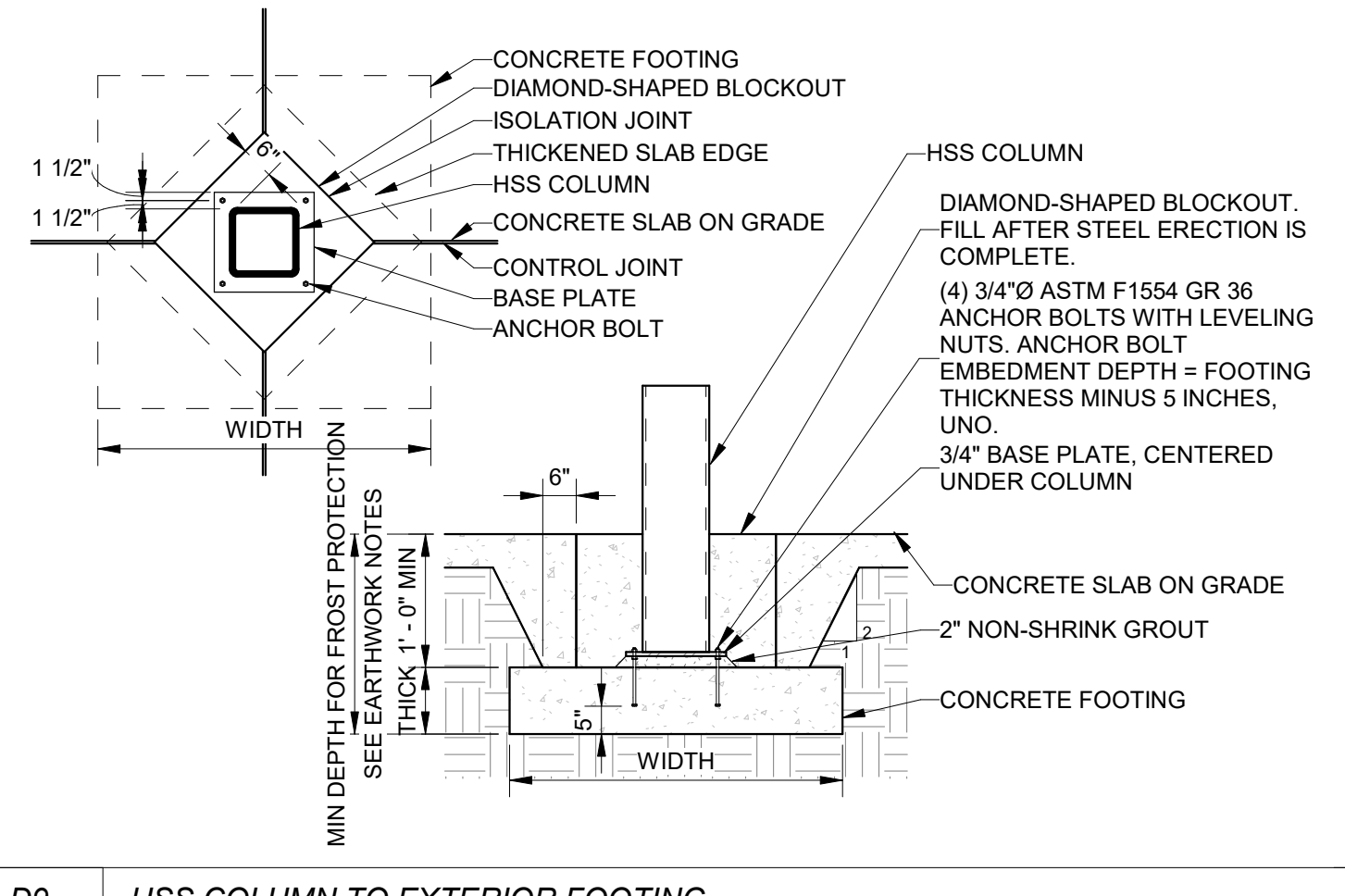

**D9** HSS COLUMN TO EXTERIOR FOOTING  
SCALE NTS

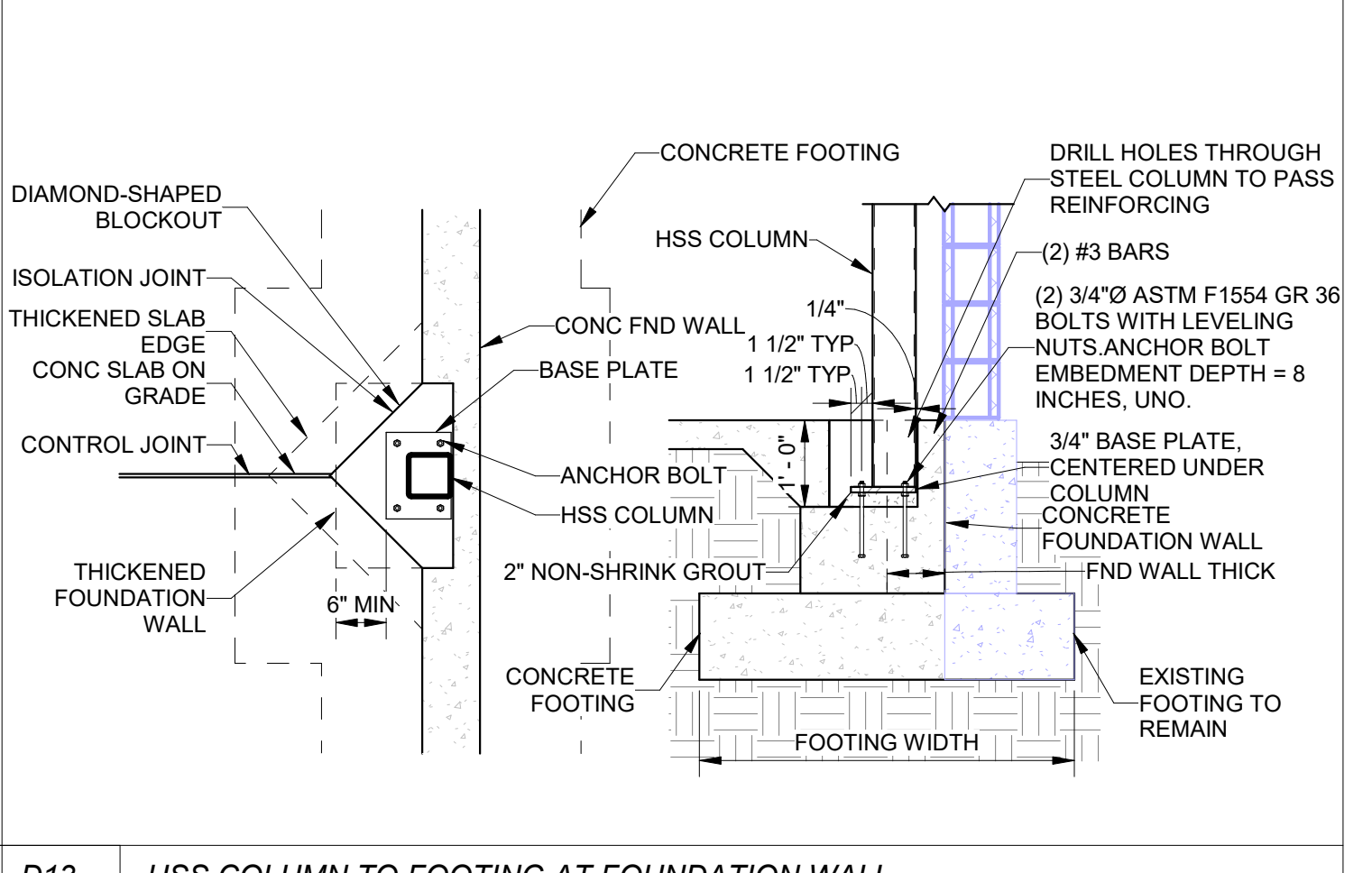

**D13** HSS COLUMN TO FOOTING AT FOUNDATION WALL  
SCALE NTS

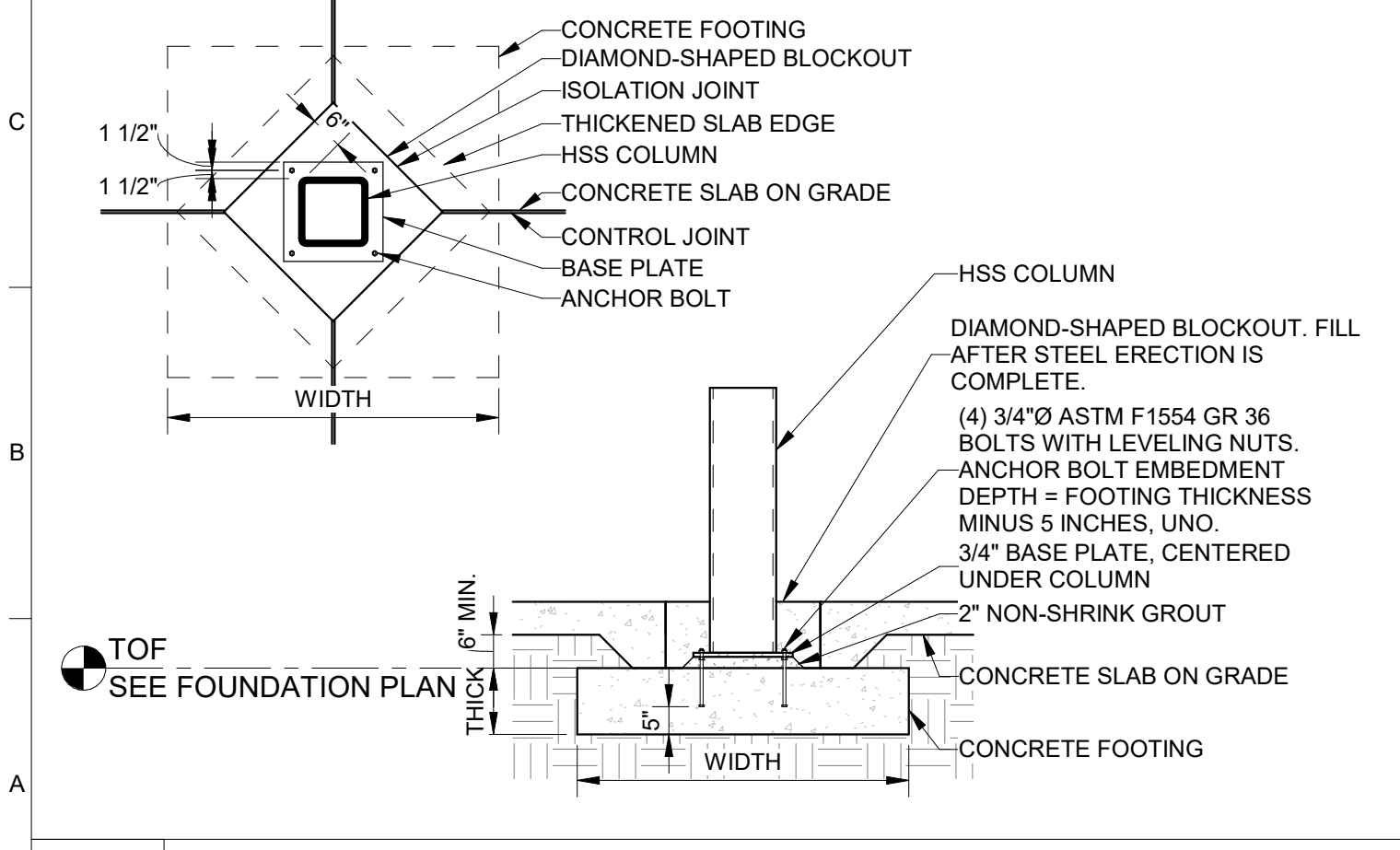

**A1** HSS COLUMN TO INTERIOR FOOTING  
SCALE NTS

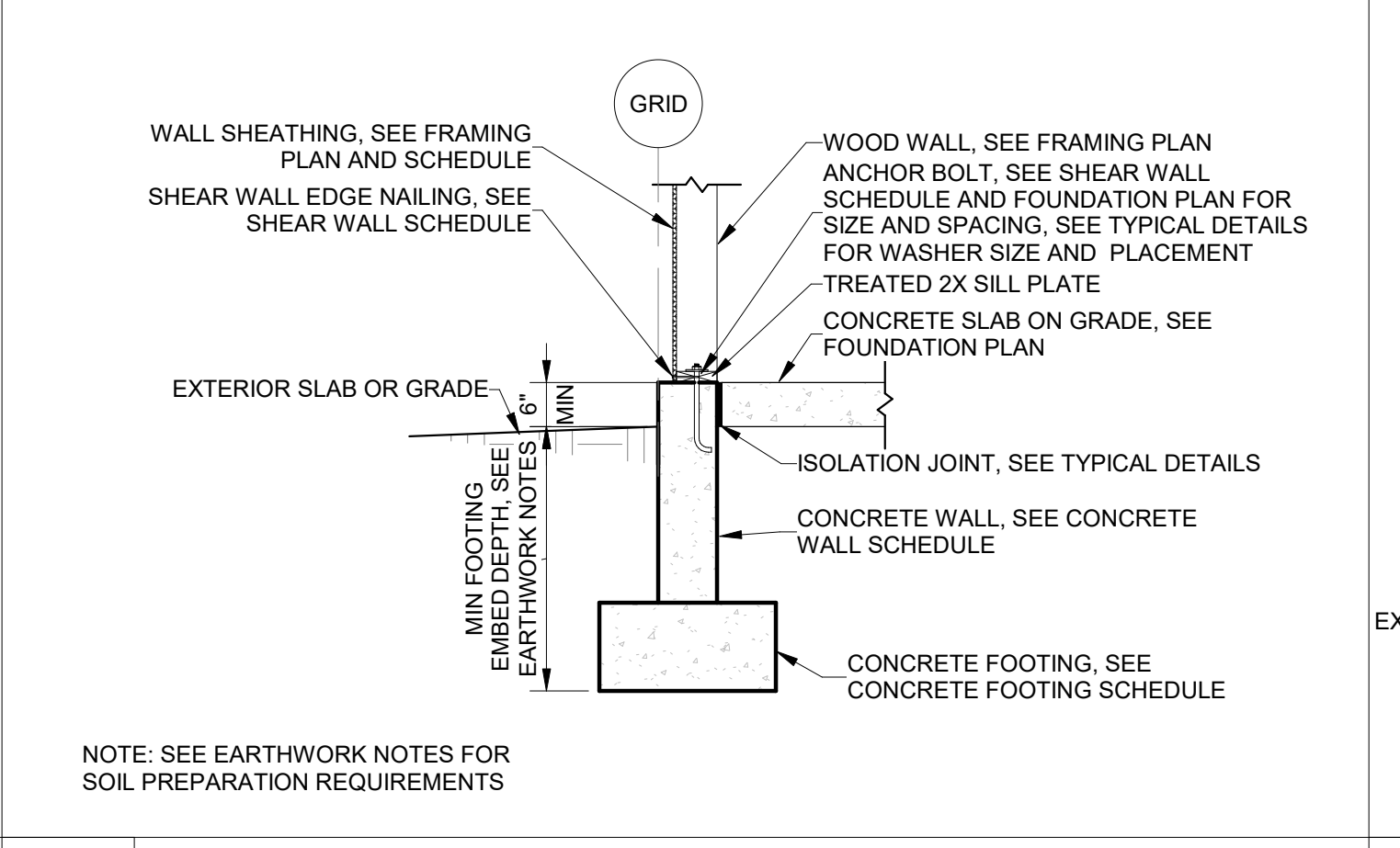

**A5** WOOD WALL ON CONCRETE FOUNDATION WALL  
SCALE NTS

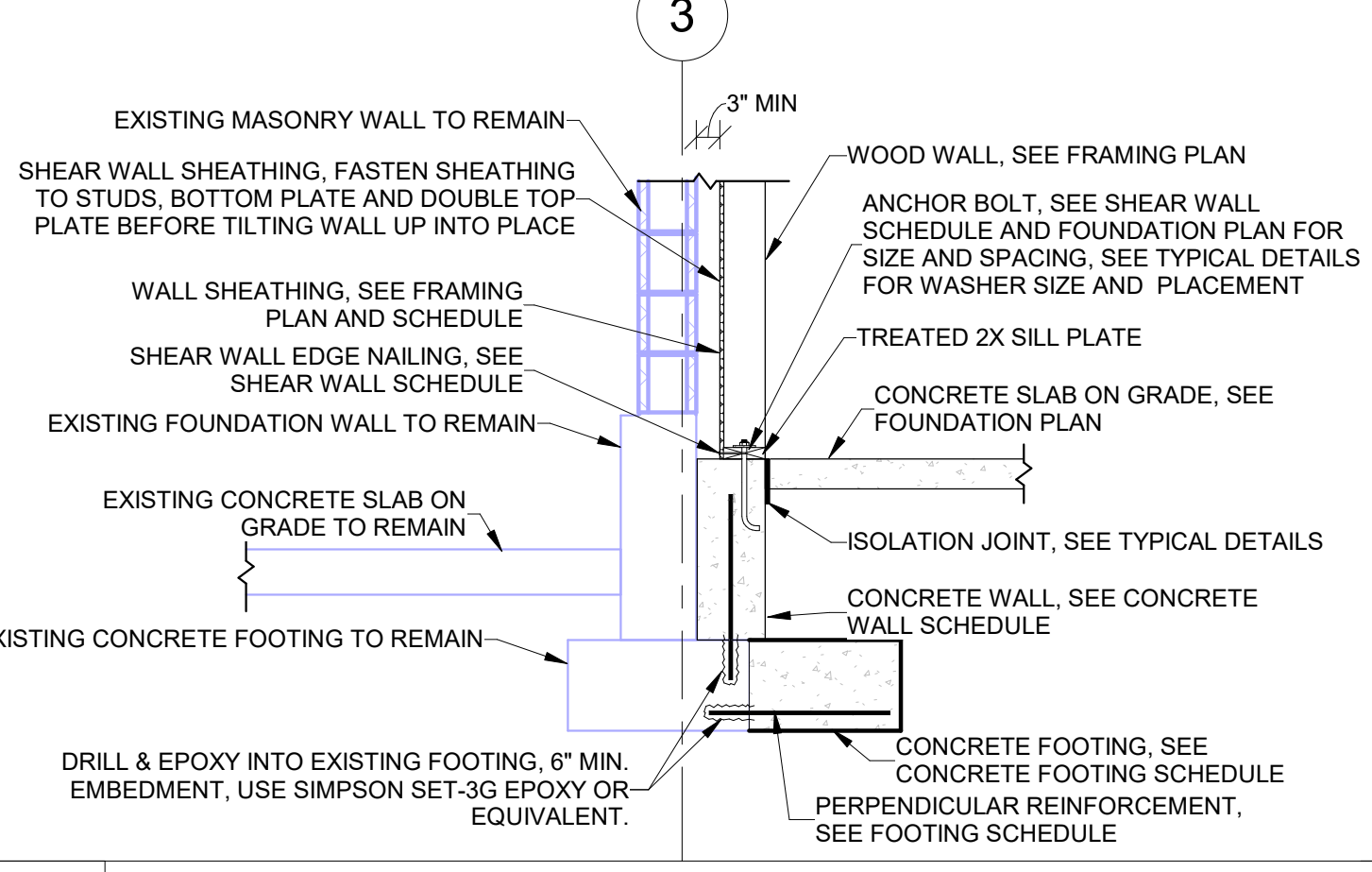

**A9** STRUCTURAL DETAIL  
SCALE NTS

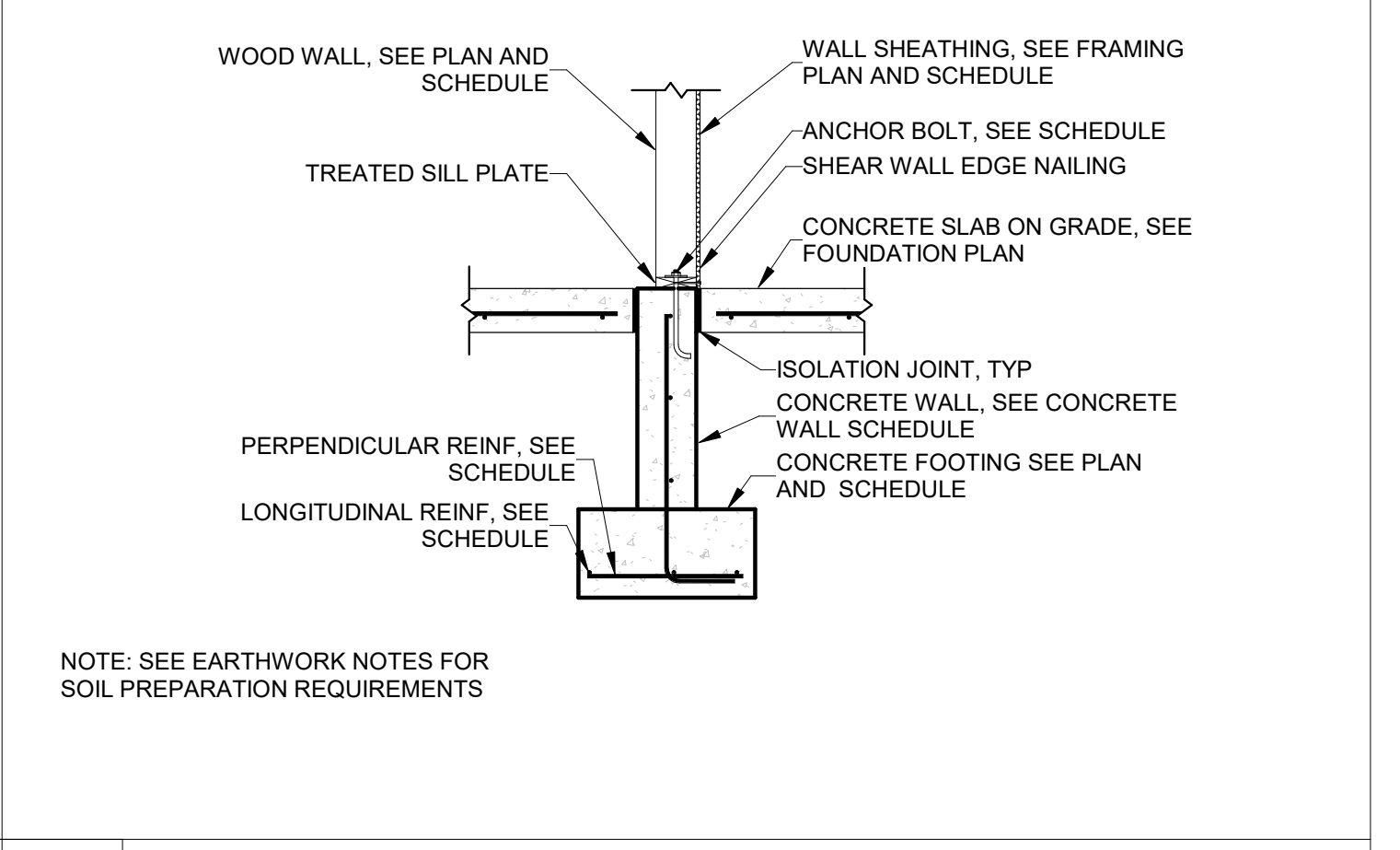

**A13** WOOD WALL ON INTERIOR FOOTING WITH CONCRETE FOUNDATION WALL  
SCALE NTS

**WELLINGTON CITY**  
ADMINISTRATION AND PUBLIC SAFETY BLDG  
JDE No.2509-014  
SUBMITTAL  
**FOR BIDDING ONLY**  
REVISIONS  
NO. DATE DESCRIPTION  
1 05/22/26 ADDENDUM NO.1  
STAMP



**campbell architecture**  
A J&D COMPANY  
campbelldesign.us | 435.628.5969

**Jones & DeMille Engineering**  
jonesanddemille.com | 800.748.5275

STRUCTURAL DETAILS  
**S-501**

File Path: \\ussdcs02\cadd\2509-014 Wellington City Office\2509-014 Wellington City Office.rvt  
Issue Date: 02/10/2026 1:22:38 PM

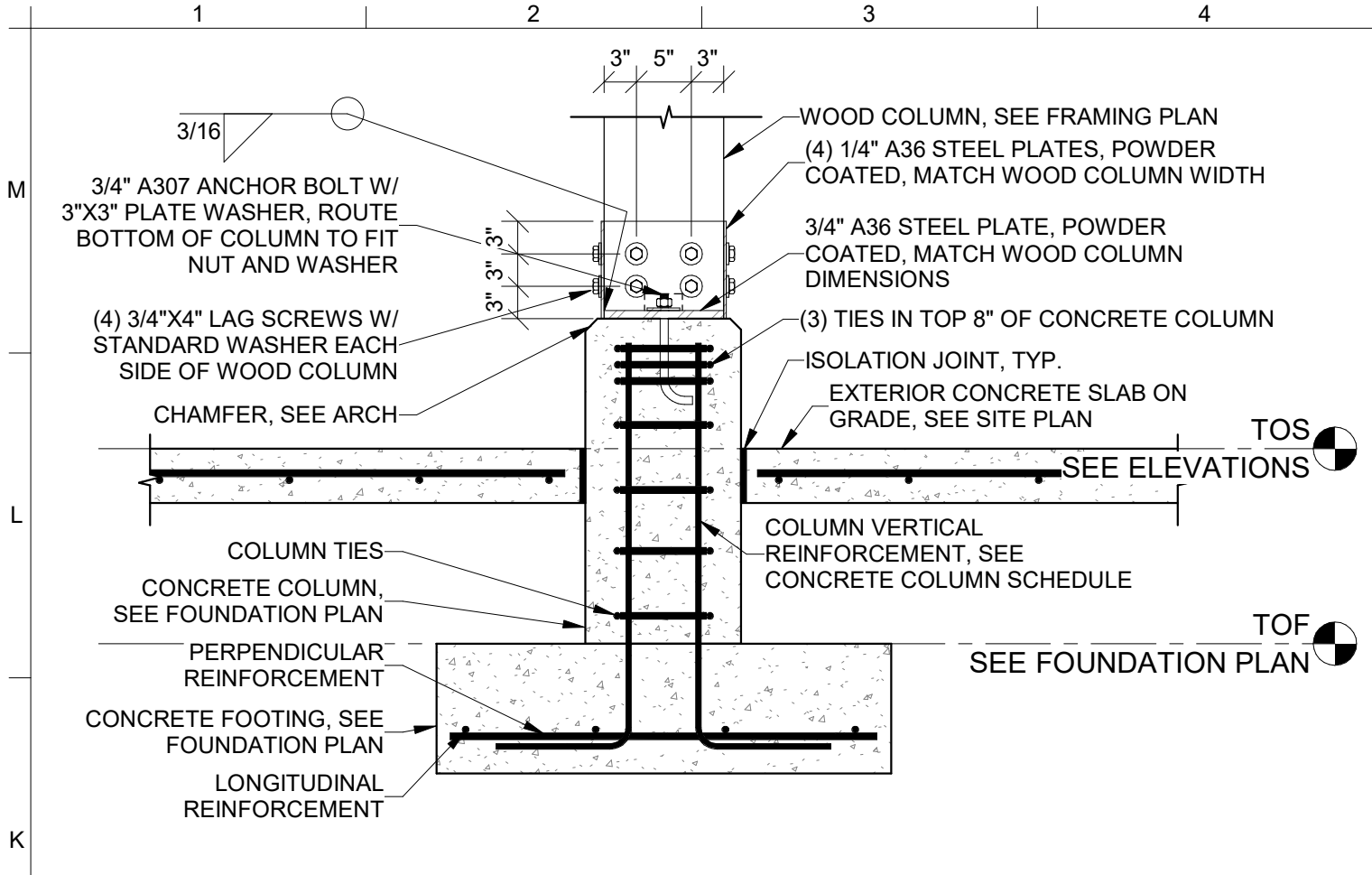

**K1 WOOD COLUMN ON CONCRETE COLUMN**  
SCALE: NTS

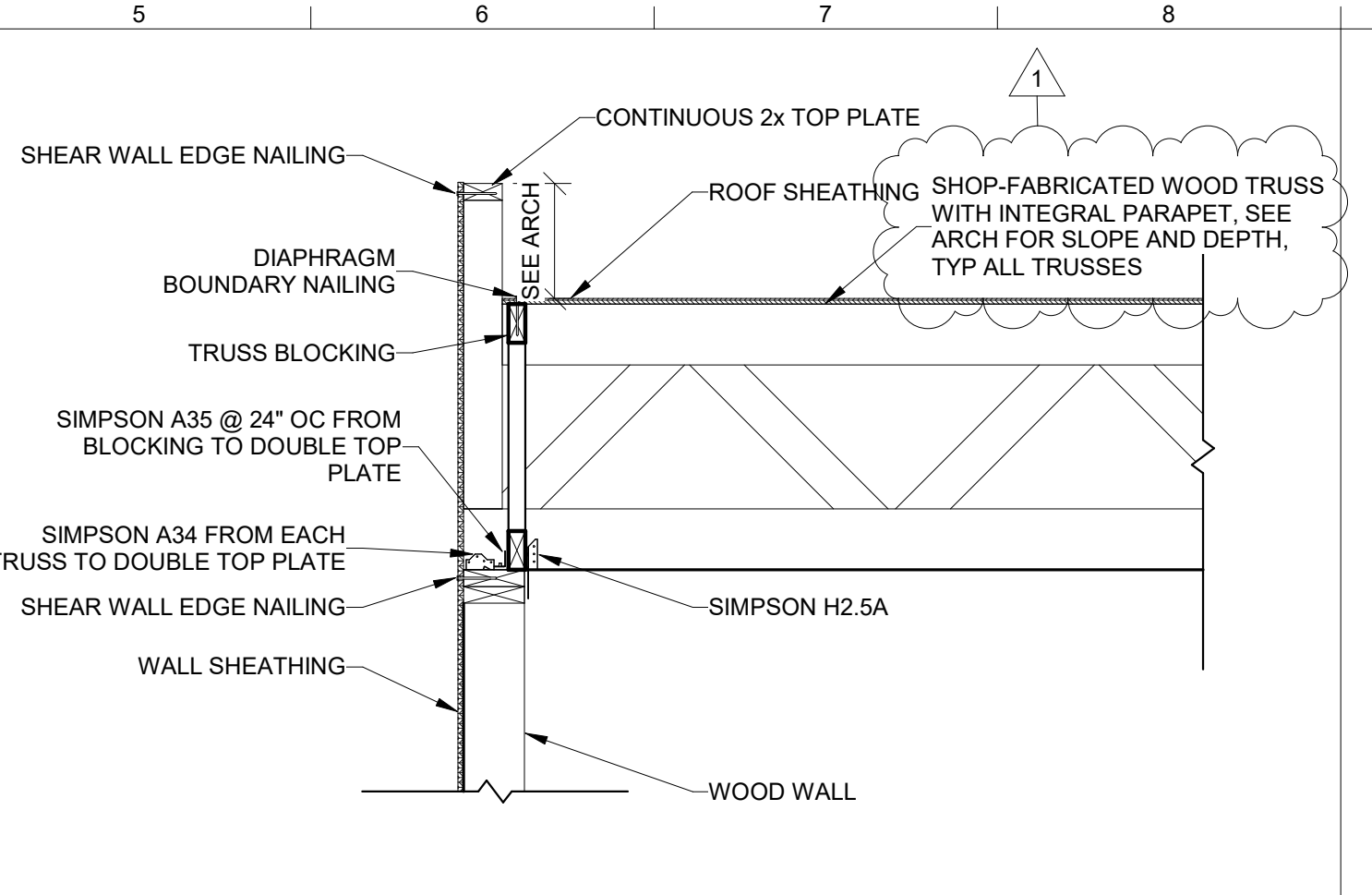

**K5 TRUSS WITH PARAPET**  
SCALE: NTS

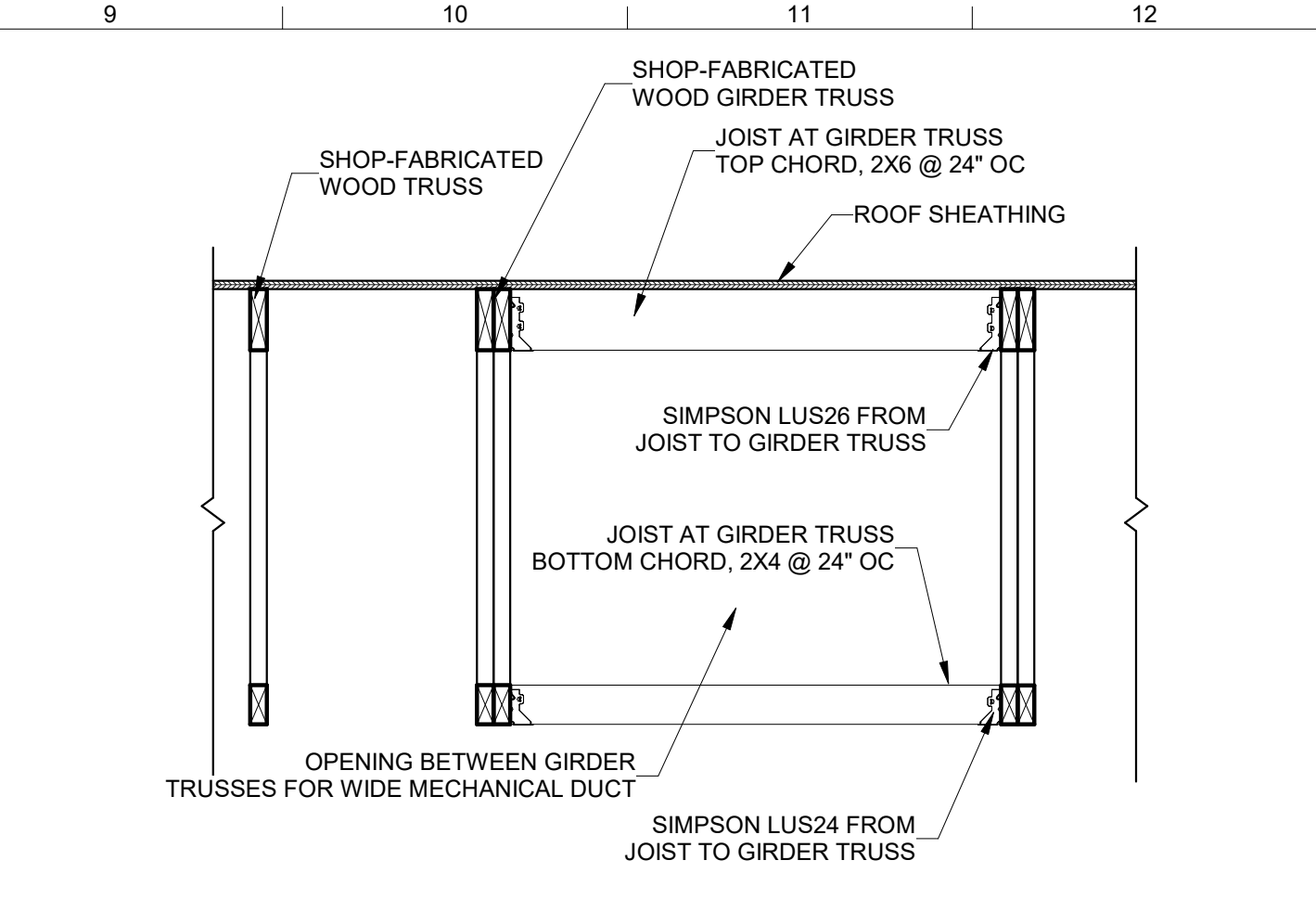

**K9 LADDER FRAMING BETWEEN GIRDER TRUSSES FOR MECHANICAL CHASE**  
SCALE: NTS

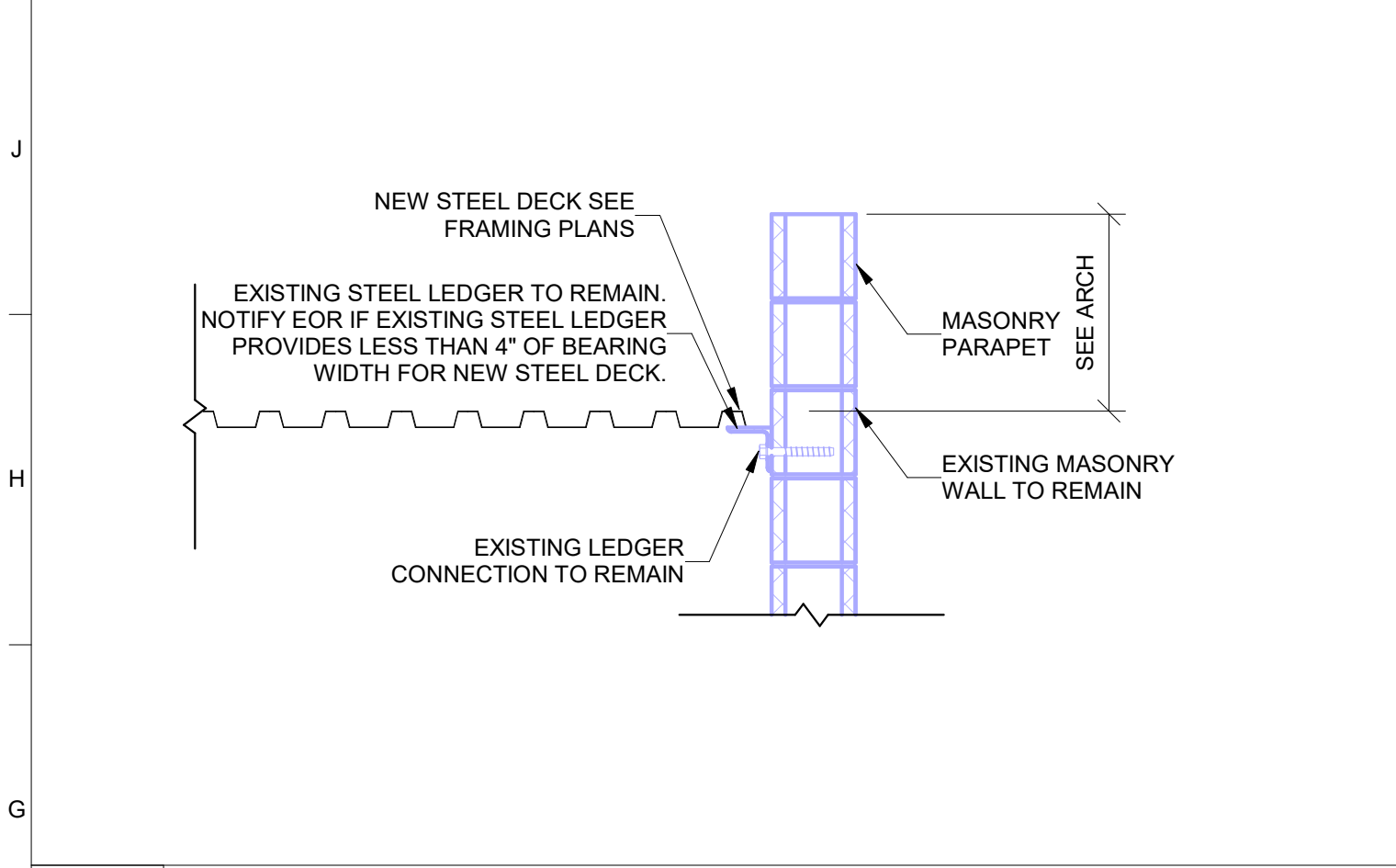

**G1 ROOF DECK TO MASONRY WALL - DECK PARALLEL TO WALL**  
SCALE: NTS

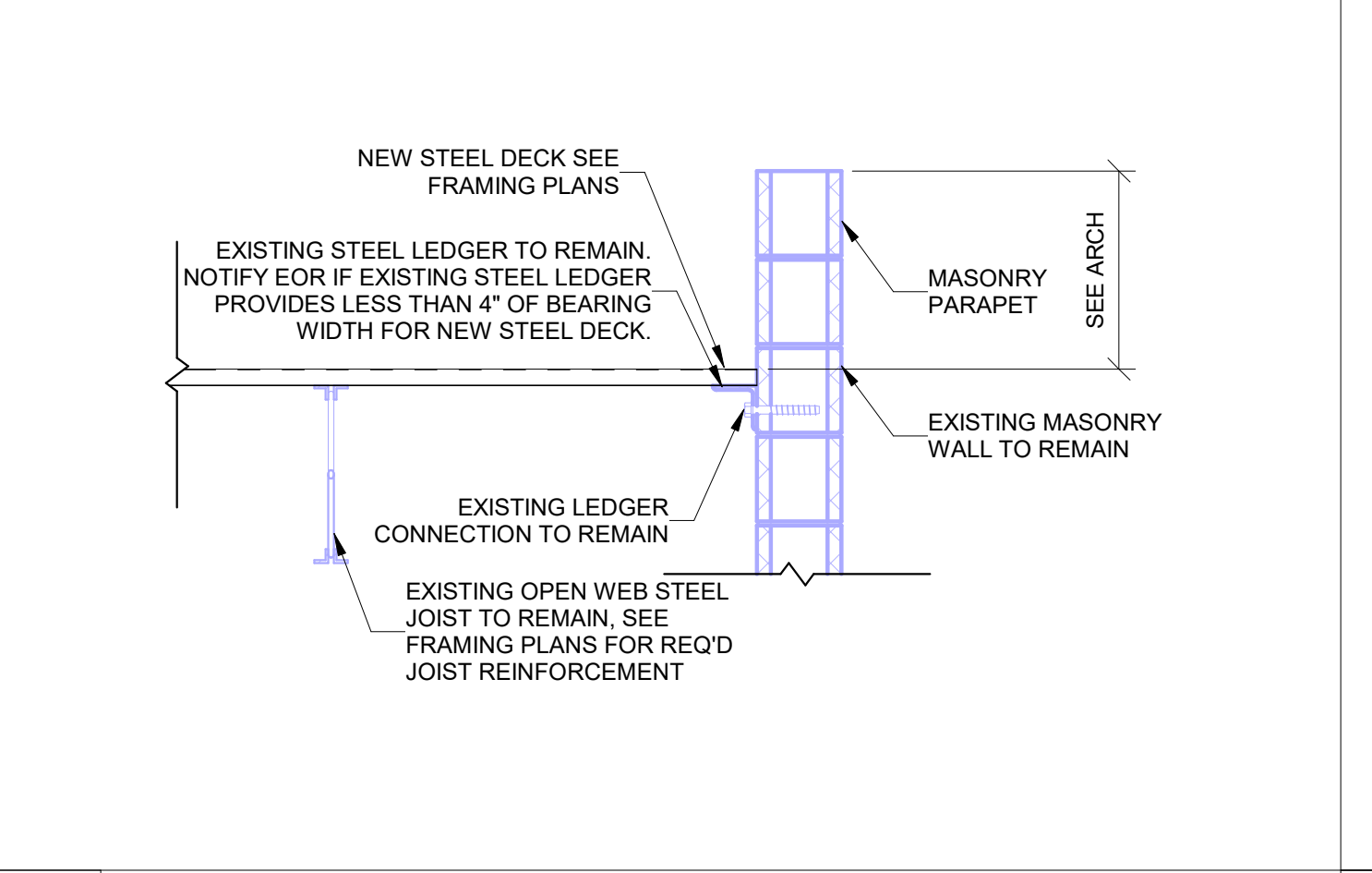

**G5 ROOF DECK TO MASONRY WALL - DECK PERPENDICULAR TO WALL**  
SCALE: NTS

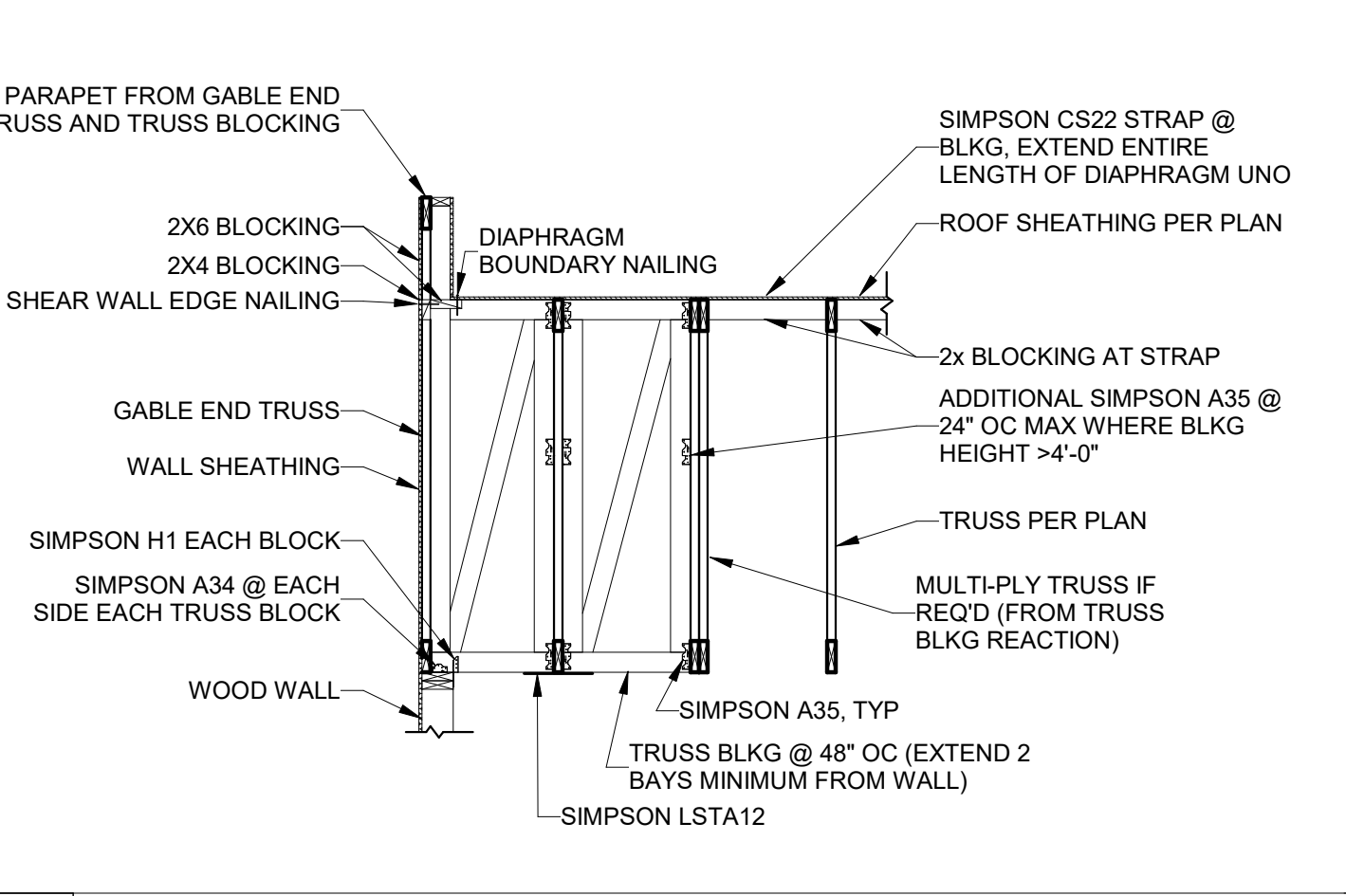

**G9 TRUSS BLOCKING ON GABLE END WITH PARAPET**  
SCALE: NTS

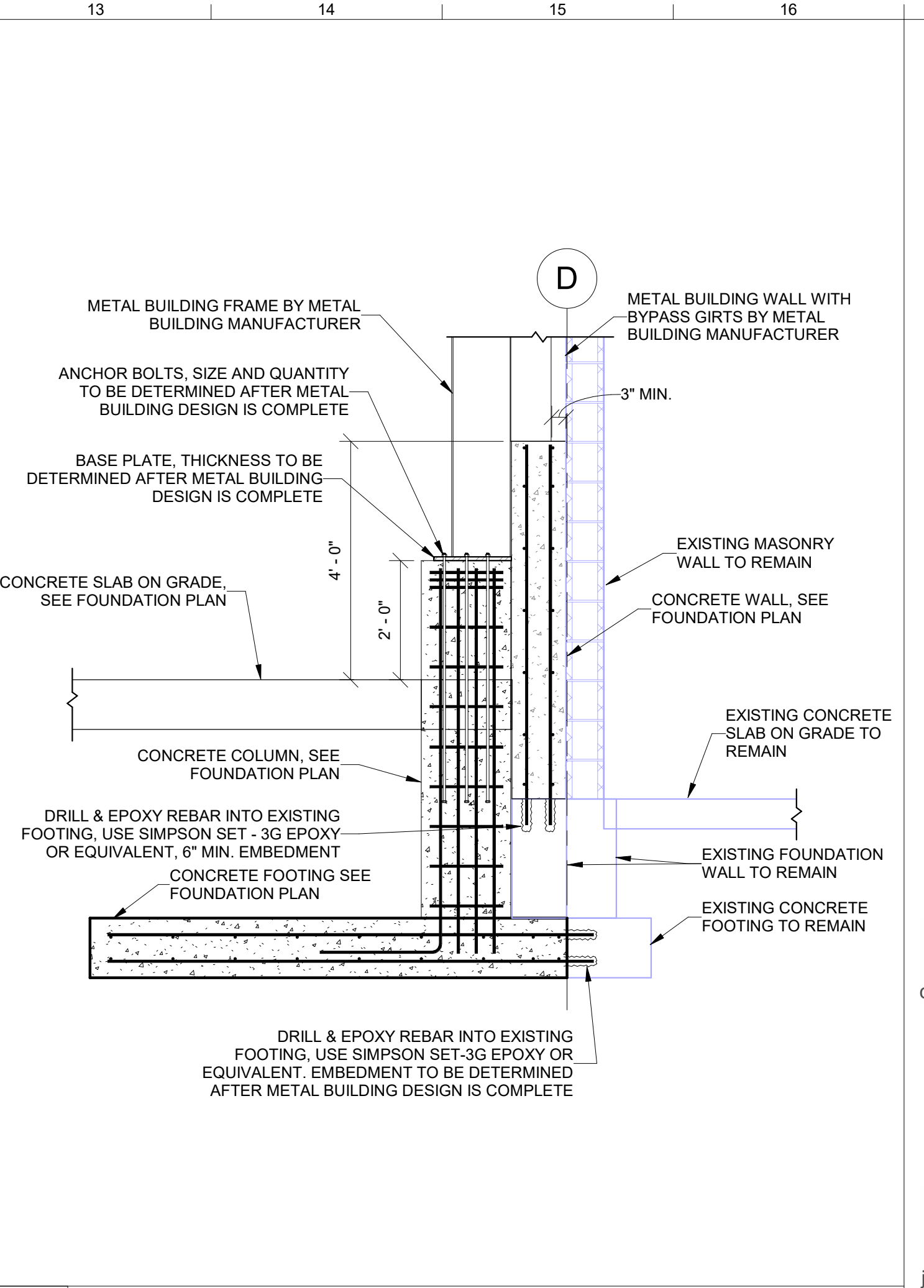

**G13 STRUCTURAL DETAIL**  
SCALE: NTS

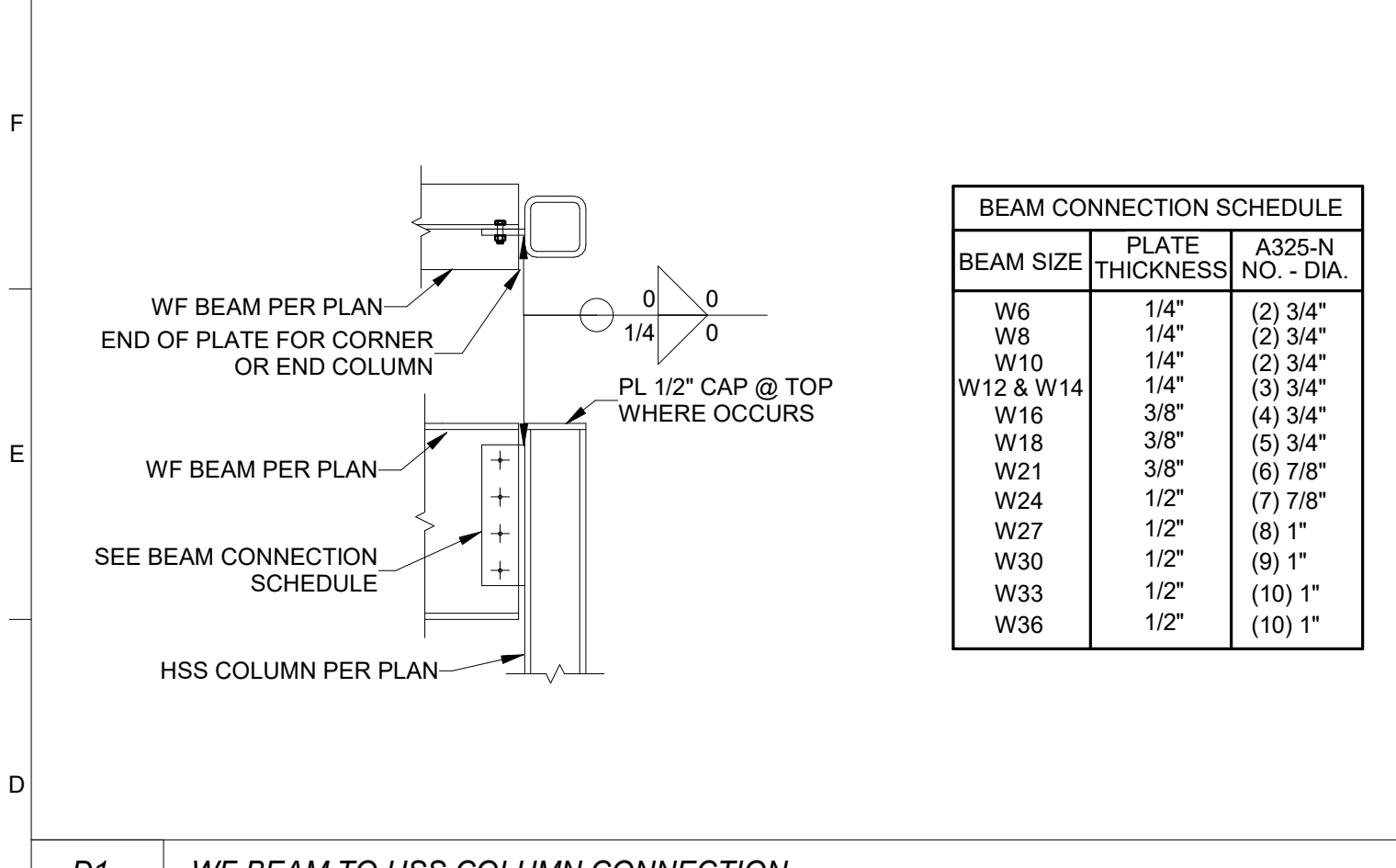

**D1 WF BEAM TO HSS COLUMN CONNECTION**  
SCALE: NTS

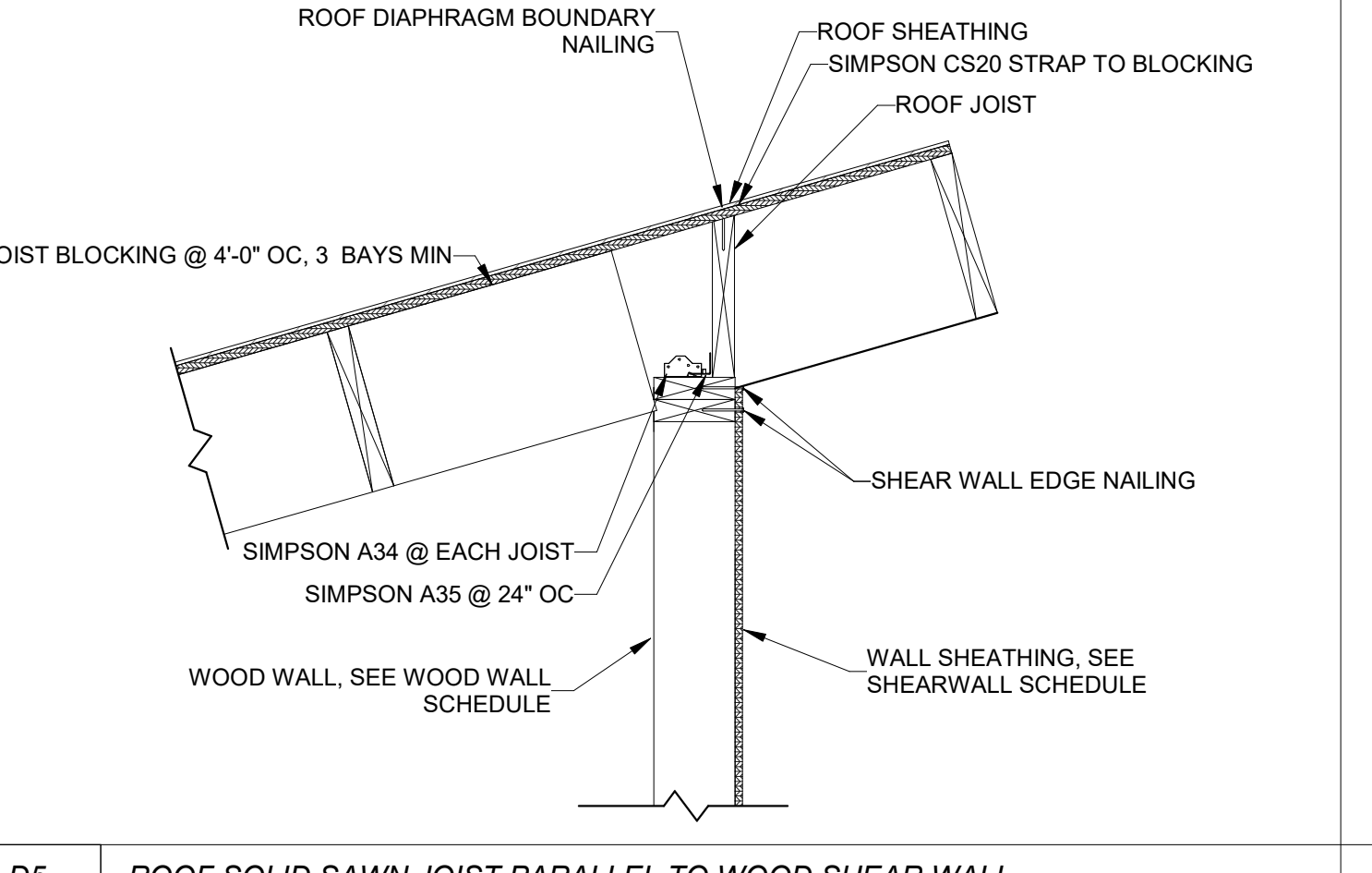

**D5 ROOF SOLID SAWN JOIST PARALLEL TO WOOD SHEAR WALL**  
SCALE: NTS

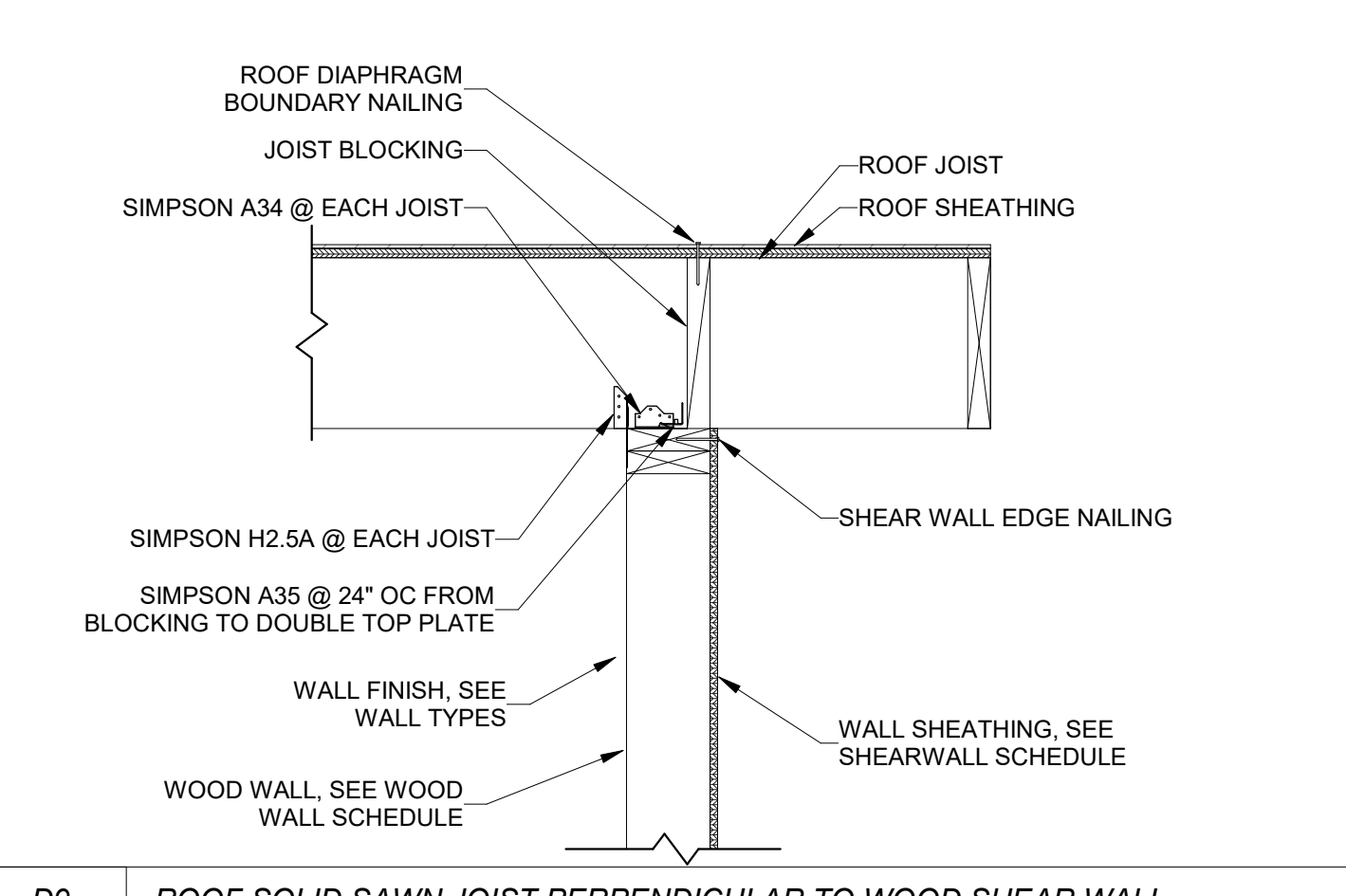

**D9 ROOF SOLID SAWN JOIST PERPENDICULAR TO WOOD SHEAR WALL**  
SCALE: NTS

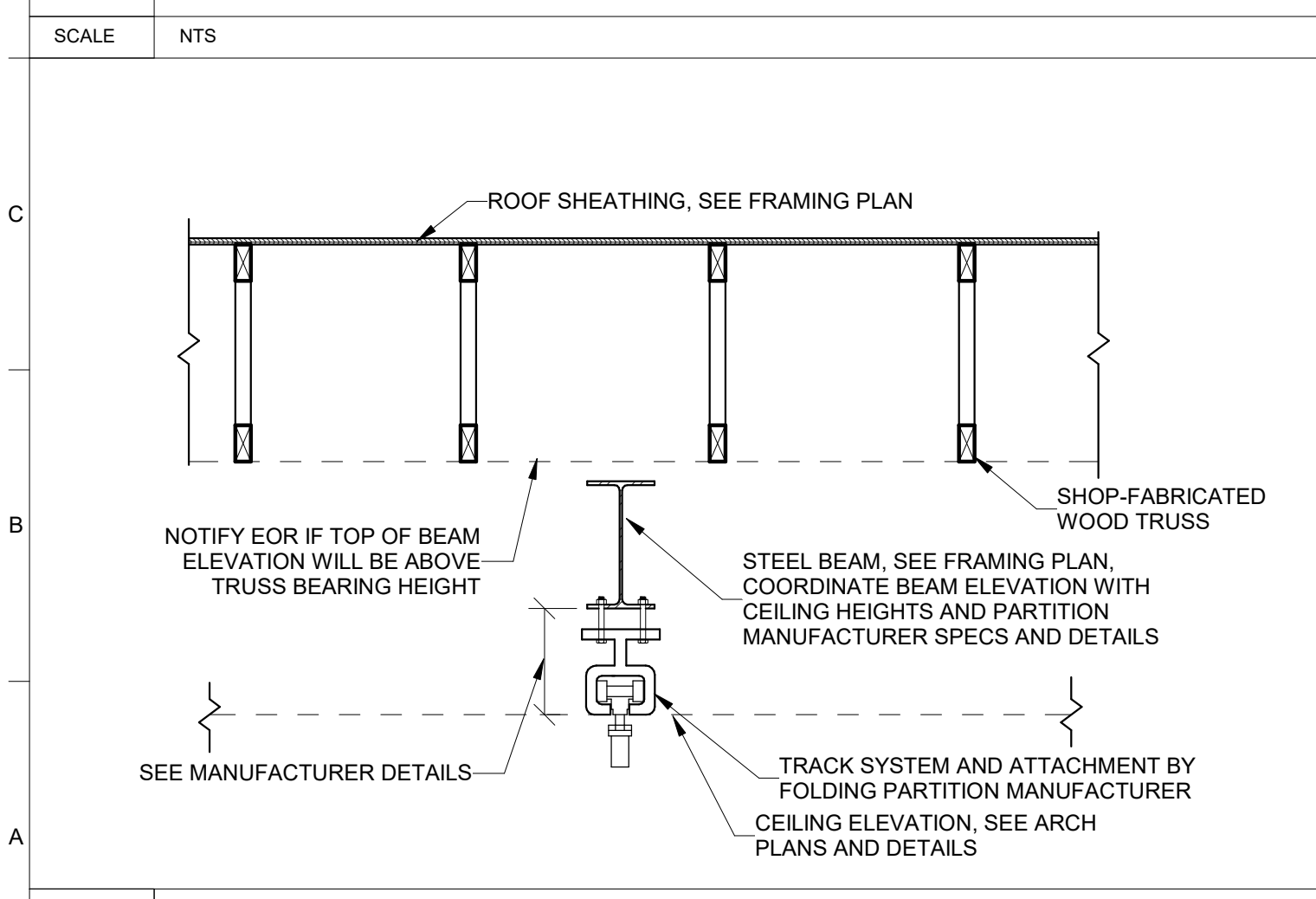

**A1 FOLDING PARTITION WALL SUPPORT BEAM**  
SCALE: NTS

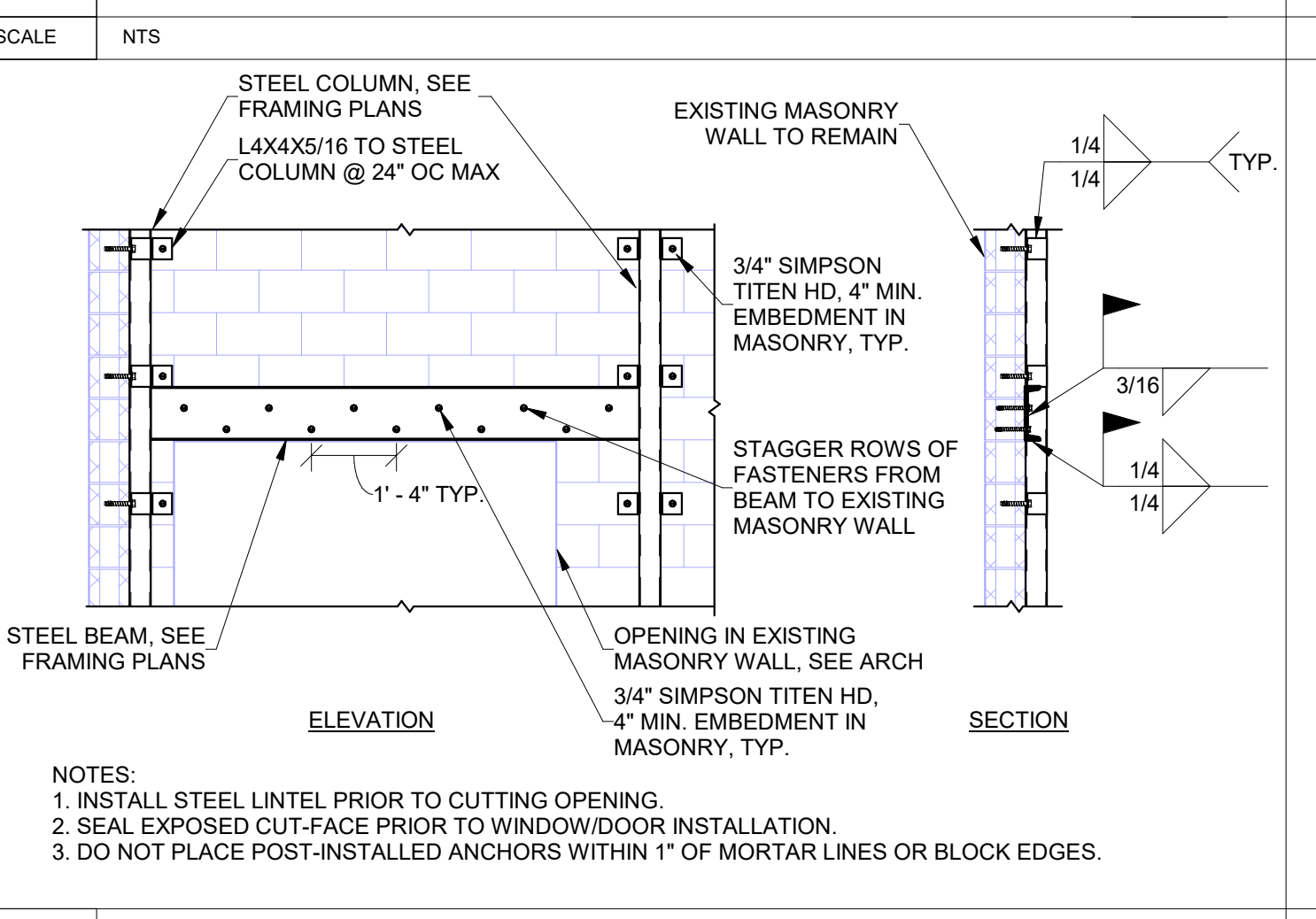

**A5 STEEL LINTEL FOR OPENING IN EXISTING MASONRY**  
SCALE: NTS

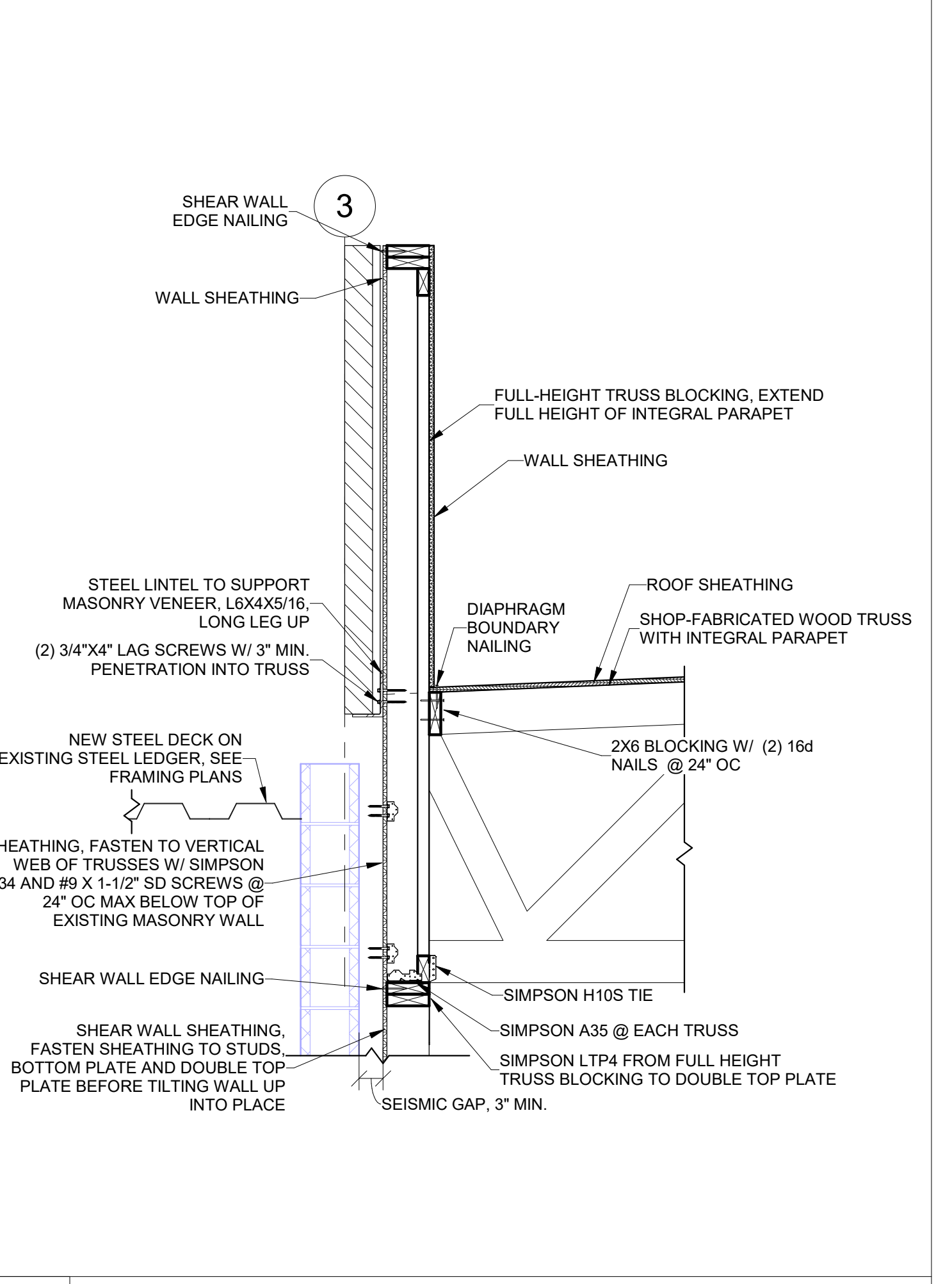

**A13 STRUCTURAL DETAIL**  
SCALE: NTS

**WELLINGTON CITY**

ADMINISTRATION AND PUBLIC SAFETY BLDG

JDE No.2509-014

SUBMITTAL

**FOR BIDDING ONLY**

REVISIONS

NO.	DATE	DESCRIPTION
1	05/22/26	ADDENDUM NO.1

STAMP

**campbell architecture**  
A J&D COMPANY  
campbelldesign.us | 435.628.5969

**Jones & DeMille Engineering**  
jonesanddemille.com | 800.748.5275

### ANCHOR BOLT SCHEDULE

MARK	DIAMETER	BOLT TYPE	SPACING	EMBED DEPTH	REMARKS
AB-1	5/8"	J-BOLT	4' - 0"	6"	3" x 3" PLATE WASHERS
AB-2	5/8"	J-BOLT	2' - 8"	6"	3" x 3" PLATE WASHERS
AB-3	5/8"	SIMPSON SABR5/8X24	N/A	18"	INSTALLED PER SIMPSON SPECIFICATIONS
AB-4	5/8"	F1554 GR 36 Heavy Hex Bolt	N/A	6"	INSTALLED PER SIMPSON SPECIFICATIONS
AB-5	7/8"	SIMPSON PA87	N/A	8"	13 1/2" MIN. COVER FROM FACE OF FOOTING TO CENTERLINE OF BOLT. INSTALL PER SIMPSON SPECIFICATIONS
AB-6	1"	PAB8	N/A	9 1/2"	16" MIN. COVER FROM FACE OF FOOTING TO CENTERLINE OF BOLT. INSTALL PER SIMPSON SPECIFICATIONS
AB-7	1"	PAB8H	N/A	8"	24" CONCRETE WALL REQUIRED. INSTALLED PER SIMPSON SPECIFICATIONS
AB-8	5/8"	F1554 GR 36 Heavy Hex Bolt	N/A	4"	INSTALLED PER SIMPSON SPECIFICATIONS
AB-9	5/8"	J-BOLT	1' - 4"	6"	3" x 3" PLATE WASHERS
AB-10	3/4"	J-BOLT	1' - 0"	6"	3" x 3" PLATE WASHERS

### WOOD WALL SCHEDULE

MARK	SPECIES	STUD SIZE	SPACING	REMARKS
WW-1	DF-L #2	2x4	16"	
WW-2	DF-L #2	2x6	16"	
WW-3	DF-L #2	2x8	16"	
WW-4	DF-L #2	2x4	12"	
WW-5	DF-L #2	2x6	12"	
WW-6	DF-L #2	2x8	12"	
WW-7	DF-L #2	2x4	24"	
WW-8	DF-L #2	2x6	24"	
WW-9	DF-L #2	2x8	24"	

### STEEL BEAM SCHEDULE

MARK	MEMBER	ELEVATION AT TOP	REMARKS
SB-1	C10X15.3	114' - 1 1/2"	
SB-2	W12X79	SEE ARCH	COORDINATE TOP OF BEAM ELEVATION WITH FOLDING PARTITION WALL MANUFACTURER AND ARCH DETAILS

### WOOD BEAM SCHEDULE

MARK	SIZE	WOOD SPECIES	END SUPPORT(S)		REMARKS
			END 1	END 2	
WB-1	(3) 2x10	DF-L #2	(1) T (3) K	(1) T (3) K	
WB-2	(2) 2x6	DF-L #2	(1) T (1) K	(1) T (1) K	
WB-3	(3) 1 3/4x9 1/2	LVL	(2) T (2) K	(2) T (2) K	
WB-4	(3) 2x6	DF-L #2	(1) T (1) K	(1) T (1) K	
WB-5	(3) 1 3/4x9 1/2	LVL	(2) T (2) K	(2) T (2) K	
WB-6	(2) 2x6	DF-L #2	(1) T (1) K	(1) T (1) K	
WB-7	(3) 2x10	DF-L #2	(1) T (1) K	(1) T (1) K	
WB-8	(2) 2x6	DF-L #2	(1) T (2) K	(1) T (2) K	
WB-9	(2) 2x6	DF-L #2	(1) T (1) K	(1) T (1) K	
WB-10	(3) 2x6	DF-L #2	(1) T (1) K	(1) T (1) K	
WB-11	(3) 1 3/4x11 1/4	LVL	(2) T (3) K	(2) T (3) K	
WB-12	(3) 2x6	DF-L #2	(1) T (-) K	WC-1	
WB-13	(3) 1 3/4x11 1/4	LVL	(2) T (2) K	(2) T (2) K	
WB-14	8X10	WC #1	(1) T (-) K	WC-2	WESTERN CEDAR, NO. 1 OR BETTER
WB-15	8X10	WC #1	WC-2	WC-2	WESTERN CEDAR, NO. 1 OR BETTER
WB-16	(2) 2x10	DF-L #2	SC-1	WC-2	
WB-17	(2) 1 3/4x9 1/4	LVL	(1) T (1) K	(1) T (1) K	
WB-18	(2) 1 3/4x9 1/4	LVL	WC-3	WC-3	

### CONCRETE COLUMN SCHEDULE

MARK	COUNT	SIZE	VERT REINF	TIES	REMARKS
CC-1	4	18 x 18	(16) #4 BARS	#3 @ 8" OC	(3) TIES WITHIN TOP 8"
CC-2	10	12 x 18	(12) #4 BARS	#3 @ 8" OC	(3) TIES WITHIN TOP 8"

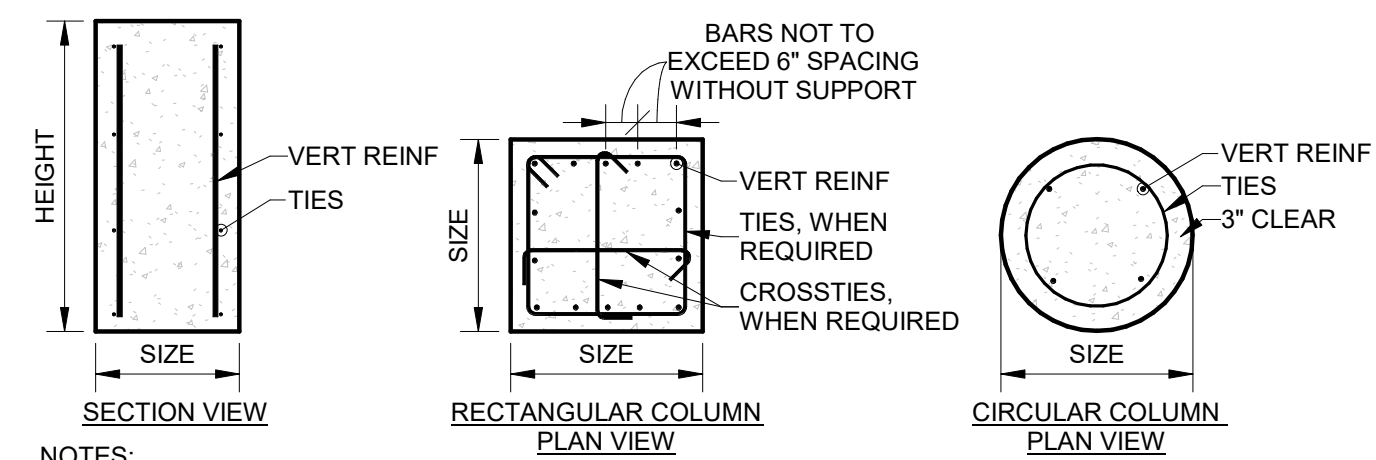

- NOTES:**
- GRAPHIC IS REPRESENTATIVE. SEE SCHEDULE ABOVE FOR ACTUAL NUMBER OF BARS REQUIRED.
  - ALL VERTICAL COLUMN REINFORCING SHALL BE TERMINATED WITH STANDARD 90° HOOKS AT BOTTOM
  - PROVIDE CROSS-TIES WHEN VERTICAL REINFORCING BARS ARE LOCATED MORE THAN 6" FROM CORNER BARS OR MORE THAN 6" FROM VERTICAL BAR ENCLOSED WITH CROSS-TIE
  - PROVIDE 135-DEGREE BEND ON ONE END OF CROSS-TIE AND 90-DEGREE BEND ON OTHER END.
  - ALTERNATE 135-DEGREE AND 90-DEGREE BENDS.

### CONCRETE FOOTING SCHEDULE

MARK	WIDTH	LENGTH	THICK	LONG REINF	PERP REINF	REMARKS
CF-1	1' - 8"	CONT.	1' - 0"	<varies>	<varies>	
CF-2	4' - 0"	4' - 0"	1' - 0"	(6) #4 BARS	(6) #4 BARS	
CF-3	3' - 0"	3' - 0"	1' - 4"	(6) #4 BARS	(6) #4 BARS	CAST HOLDOWN ANCHOR BOLT IN PLACE
CF-4	3' - 0"	3' - 0"	1' - 0"	(5) #4 BARS	(5) #4 BARS	

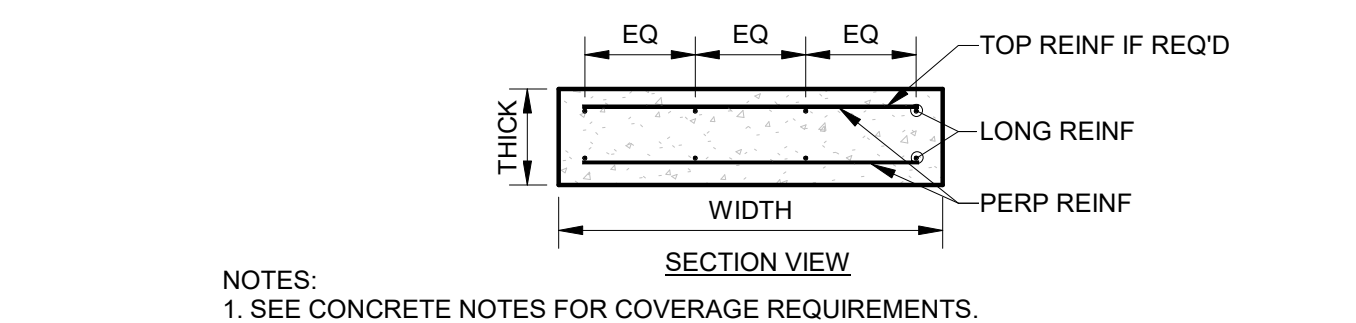

- NOTES:**
- SEE CONCRETE NOTES FOR COVERAGE REQUIREMENTS.

### CONCRETE WALL SCHEDULE

MARK	THICKNESS	HORIZ REINF	VERT REINF	TYPE	REMARKS
CW-1	8"	#4 @ 12" OC	#4 @ 12" OC	A	
CW-2	10"	(2) MATS OF #4 @ 18" OC	(2) MATS OF #4 @ 18" OC	D	
CW-3	11"	(2) MATS OF #4 @ 18" OC	(2) MATS OF #4 @ 18" OC	D	
CW-4	8"	#4 @ 18" OC	#4 @ 18" OC	A	
CW-5	9"	#4 @ 12" OC	#4 @ 12" OC	A	
CW-6	1' - 4"	(2) MATS OF #4 @ 12" OC	(2) MATS OF #4 @ 12" OC	D	

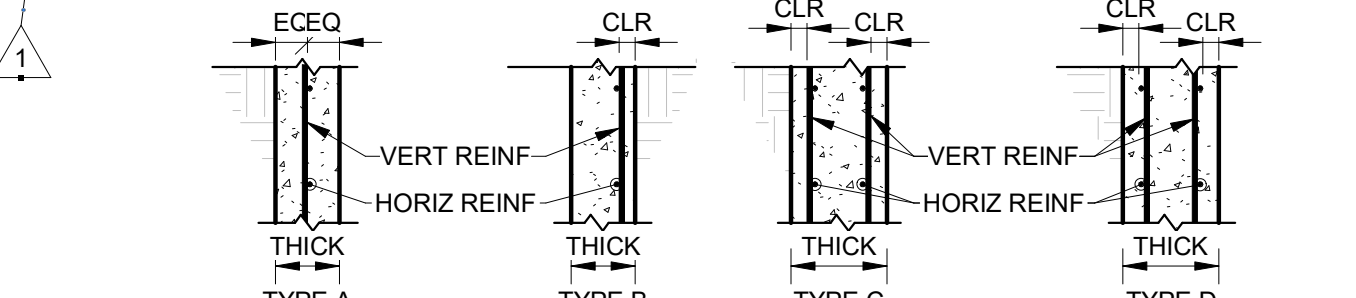

- NOTES:**
- EF = EACH FACE OF = OUTSIDE FACE (AGAINST SOIL) IF = INSIDE FACE
  - SEE CONCRETE NOTES FOR COVERAGE REQUIREMENTS.

### SHEARWALL SCHEDULE

MARK	SHEATHING SIZE	BOTH SIDES?	EDGE NAILING	FIELD NAILING	STUDS	SILL BOLT	BLOCKING	REMARKS
1	7/16" OSB	NO	8d COMMON @ 6" OC	8d COMMON @ 12" OC	2x	AB-1	YES	
2	7/16" OSB	NO	8d COMMON @ 4" OC	8d COMMON @ 12" OC	2x	AB-2	YES	
4	7/16" OSB	YES	8d COMMON @ 6" OC	8d COMMON @ 12" OC	2x	AB-9	YES	
5	7/16" OSB	YES	8d COMMON @ 4" OC	8d COMMON @ 12" OC	2x	AB-9	YES	

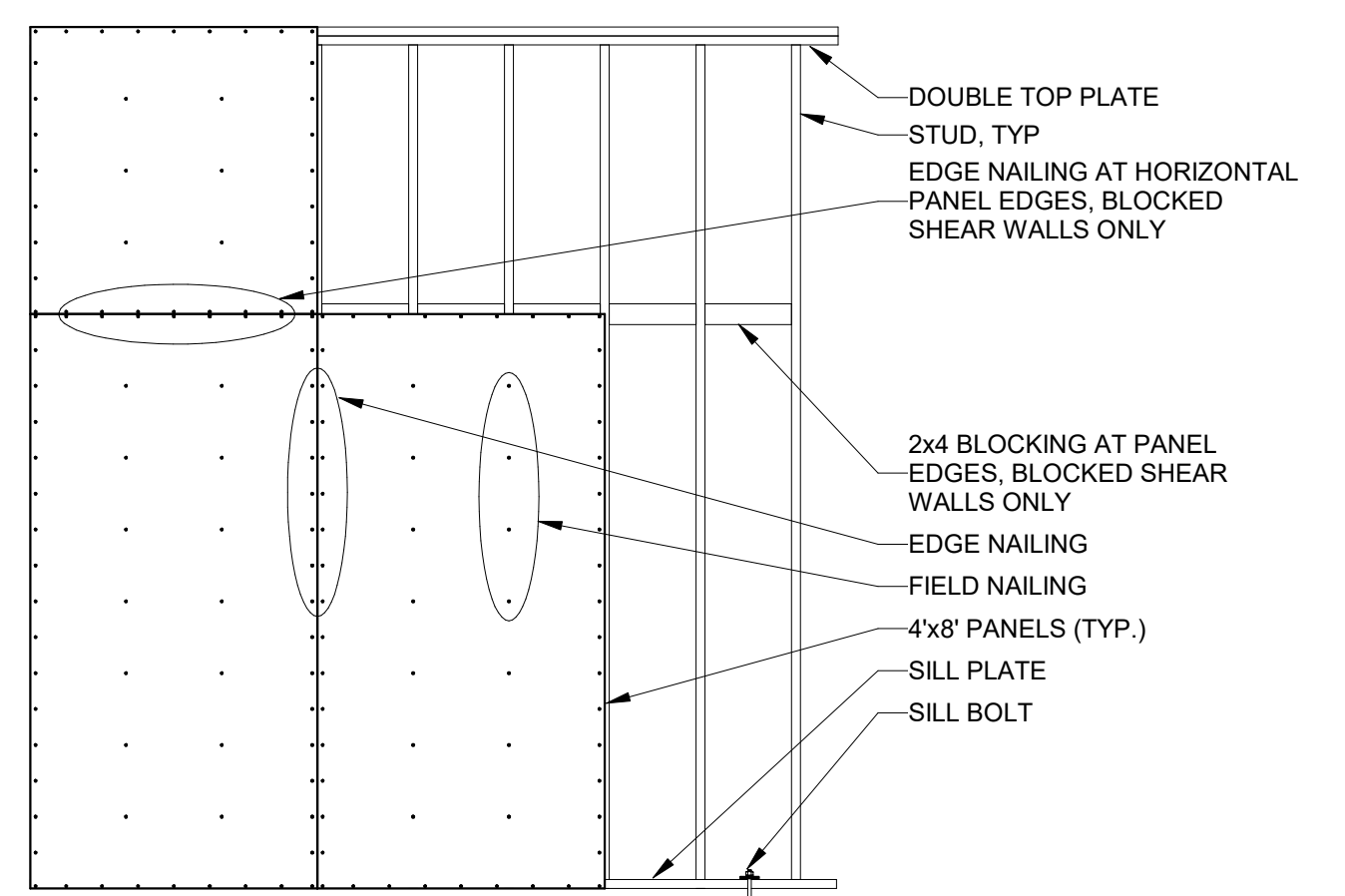

- NOTE:**
- SHEATHING ORIENTATION: LONG DIRECTION (STRONG AXIS) PARALLEL TO FRAMING & SHORT DIRECTION (WEAK AXIS) PERPENDICULAR TO FRAMING.
  - COMMON NAILS SPECIFIED IN THE SHEAR WALL SCHEDULE ABOVE MAY BE SUBSTITUTED WITH GALVANIZED BOX NAILS AS SHOWN IN THE TABLE BELOW.
- | COMMON NAIL                | GALVANIZED BOX NAIL        |
|----------------------------|----------------------------|
| 6d (2 x 0.113 x 0.266)     | 6d (2 x 0.099 x 0.266)     |
| 8d (2-1/2 x 0.131 x 0.281) | 8d (2-1/2 x 0.113 x 0.297) |
| 10d (3 x 0.148 x 0.312)    | 10d (3 x 0.128 x 0.312)    |

### HOLDOWN SCHEDULE

MARK	COUNT	TYPE	ANCHOR BOLT	FASTENERS	REMARKS
6	43	SIMPSON HDUE3-SDS3	AB-3	7-SDS 1/4"x 3"	
9	8	SIMPSON HDUE9-SDS3.5	AB-5	16-SDS 1/4"x 3 1/2"	NO POST-INSTALLED ANCHOR OPTIONS AVAILABLE. ANCHOR BOLT MUST BE CAST IN PLACE. SEE ANCHOR BOLT SCHEDULE AND TYPICAL DETAILS.
10	2	SIMPSON HDUE13-SDS3.5	AB-6	23-SDS 1/4"x 3 1/2"	NO POST-INSTALLED ANCHOR OPTIONS AVAILABLE. ANCHOR BOLT MUST BE CAST IN PLACE. SEE ANCHOR BOLT SCHEDULE AND TYPICAL DETAILS.

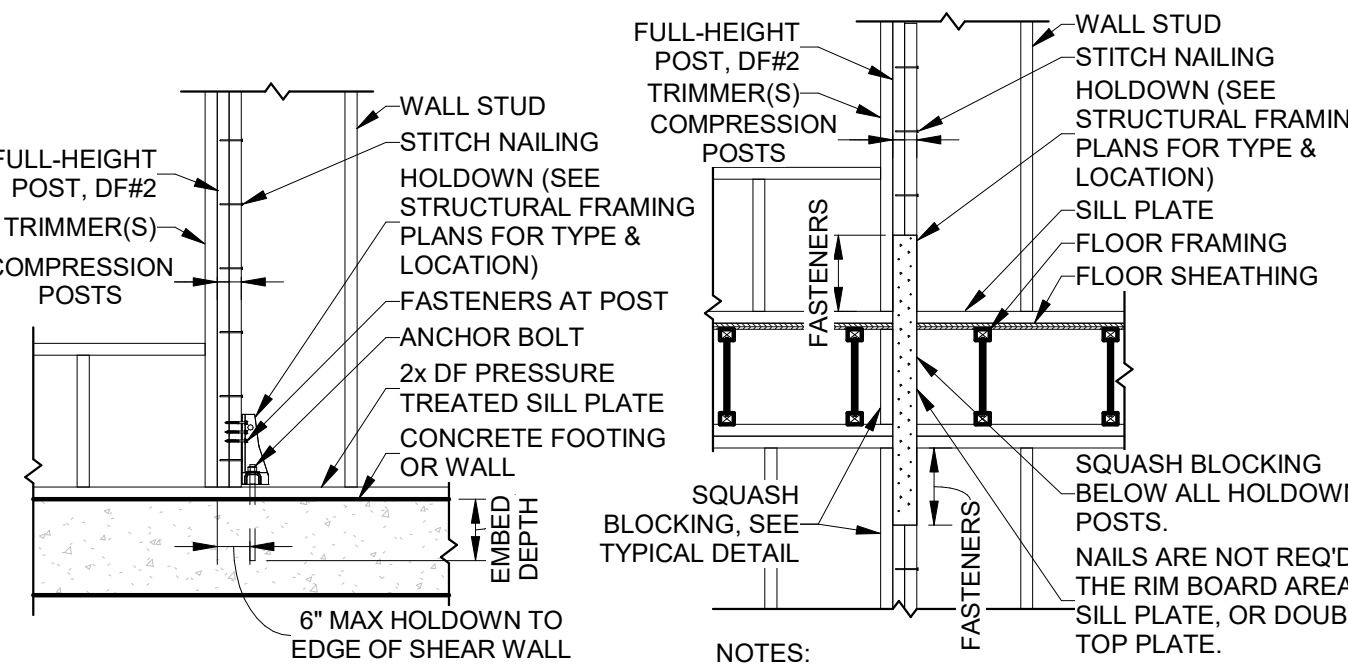

- NOTES:**
- WHEN NAILING THE STRAP OVER OSB/PLYWOOD, USE A 2 1/2" LONG NAIL, MINIMUM.
  - RIM BOARD NOT SHOWN FOR CLARITY.
  - WALL SHEATHING NOT SHOWN FOR CLARITY.
- HOLDOWN AT FOUNDATION**
- NOTES:**
- HOLDOWNS SHALL BE INSTALLED WITHIN 6" OF EDGE OF SHEAR WALL OR EDGE OF OPENING.
  - PROVIDE SHEAR WALL EDGE NAILING TO FULL-HEIGHT POST.
  - HOLDOWNS AND STRAPS ON MULTI-STORY BUILDINGS SHALL BE ALIGNED TO PROVIDE A CONTINUOUS VERTICAL LOAD PATH TO THE FOUNDATION.
- HOLDOWN AT INTERMEDIATE FLOOR**

### STEEL COLUMN SCHEDULE

MARK	MEMBER	BASE PLATE		ANCHOR BOLT		REMARKS
		SIZE	THICK	NO.	DIAMETER	
SC-1	HSS5X5X5/16	11" X 11"	3/4"	(4)	3/4"	
SC-2	HSS4X4X5/16	7" X 7"	3/4"	(4)	3/4"	COLUMN IS IN CORNER OF BASE PLATE
SC-3	HSS4X4X5/16	10" X 10"	3/4"	(4)	3/4"	

### STEEL LINTEL FOR MASONRY VENEER

MAX OPENING WIDTH	LINTEL	REMARKS
6' - 0"	L3x3x3/16	
9' - 0"	L5x3x1/4	
12' - 0"	L6x3-1/2x3/8	
16' - 0"	L8x4x1	

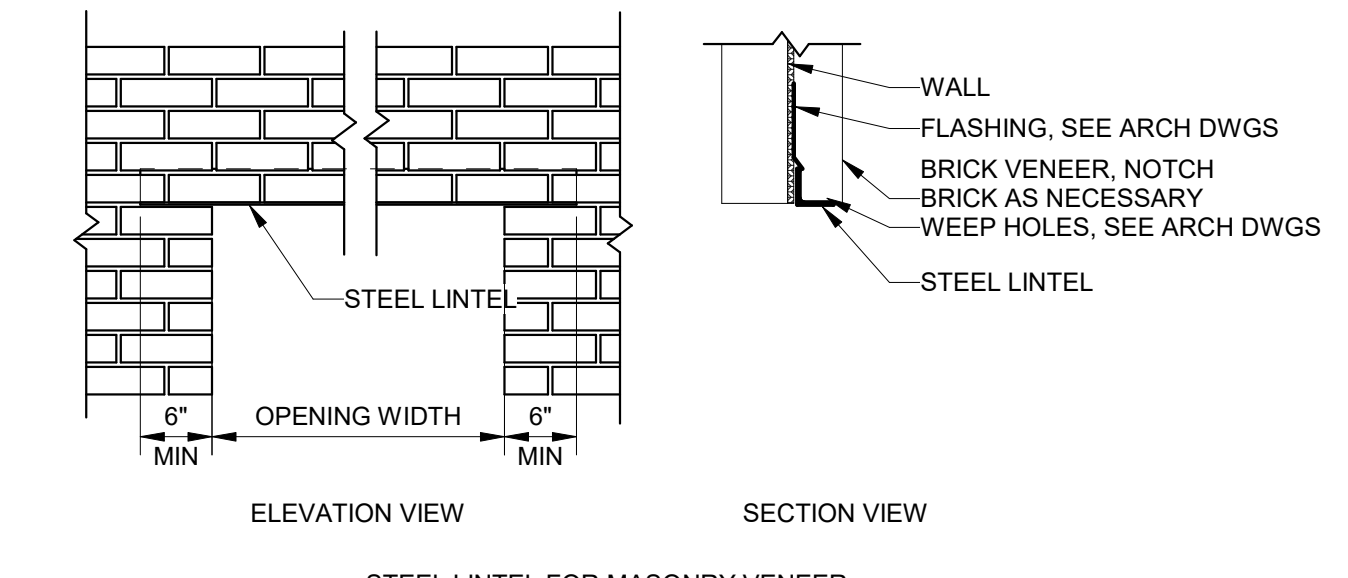

- NOTES:**
- LINTELS WITH UNEVEN LEGS SHALL BE ORIENTED WITH THE LONG LEG VERTICAL.

### STEEL DECK SCHEDULE

MARK	PROFILE	GAGE	MINIMUM PROPERTIES (PER FOOT OF WIDTH)			MINIMUM NUMBER OF DECK SPANS	REMARKS
			+S (IN3)	-S (IN3)	I (IN4)		
SD-1	1.5B-36GR50	18	0.306	0.318	.277	2	

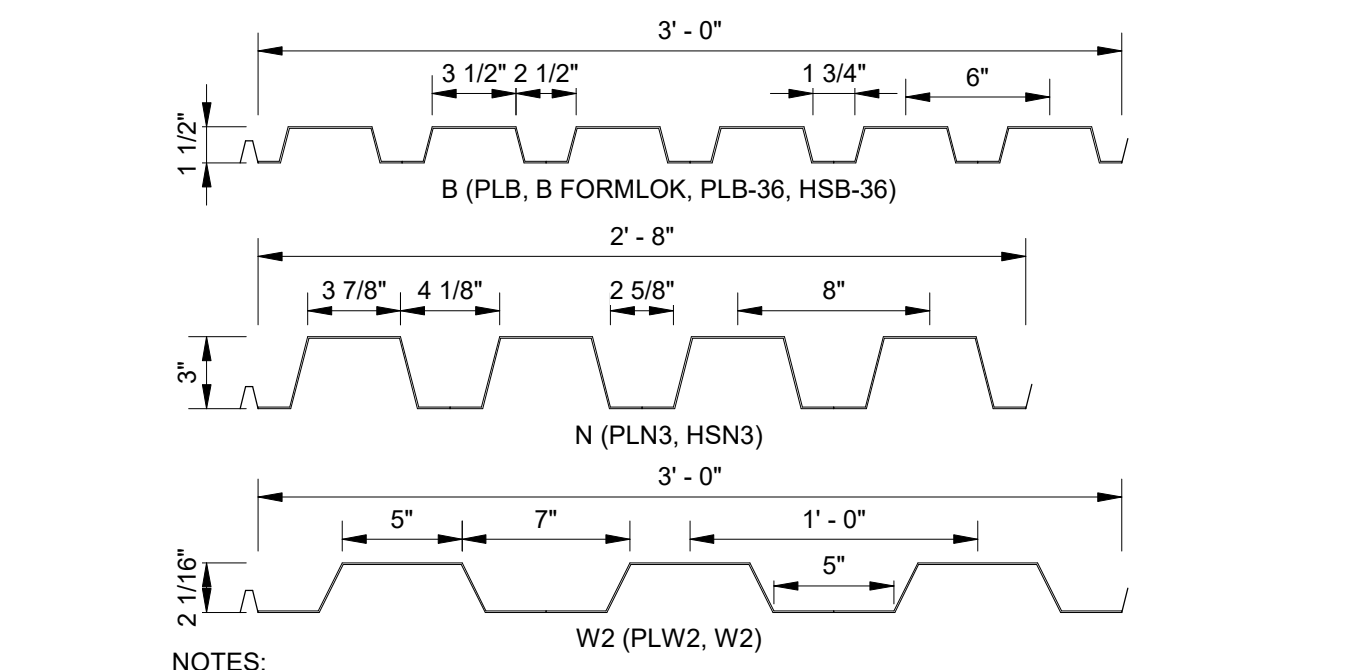

- NOTES:**
- DECK PROFILE SUBSTITUTIONS MUST BE APPROVED BY THE ENGINEER OF RECORD.

### STEEL DECK ATTACHMENT SCHEDULE

MARK	SUPPORT ATTACHMENT PATTERN	SUPPORT ATTACHMENT TYPE	SIDE LAP ATTACHMENT	CONNECTION TO ALL PARALLEL MEMBERS	REMARKS
SD-1	36/4	5/8" DIA. ARC SPOT WELD	#10 SCREWS @ 8" OC	5/8" DIA. ARC SPOT WELDS @ 18" OC	

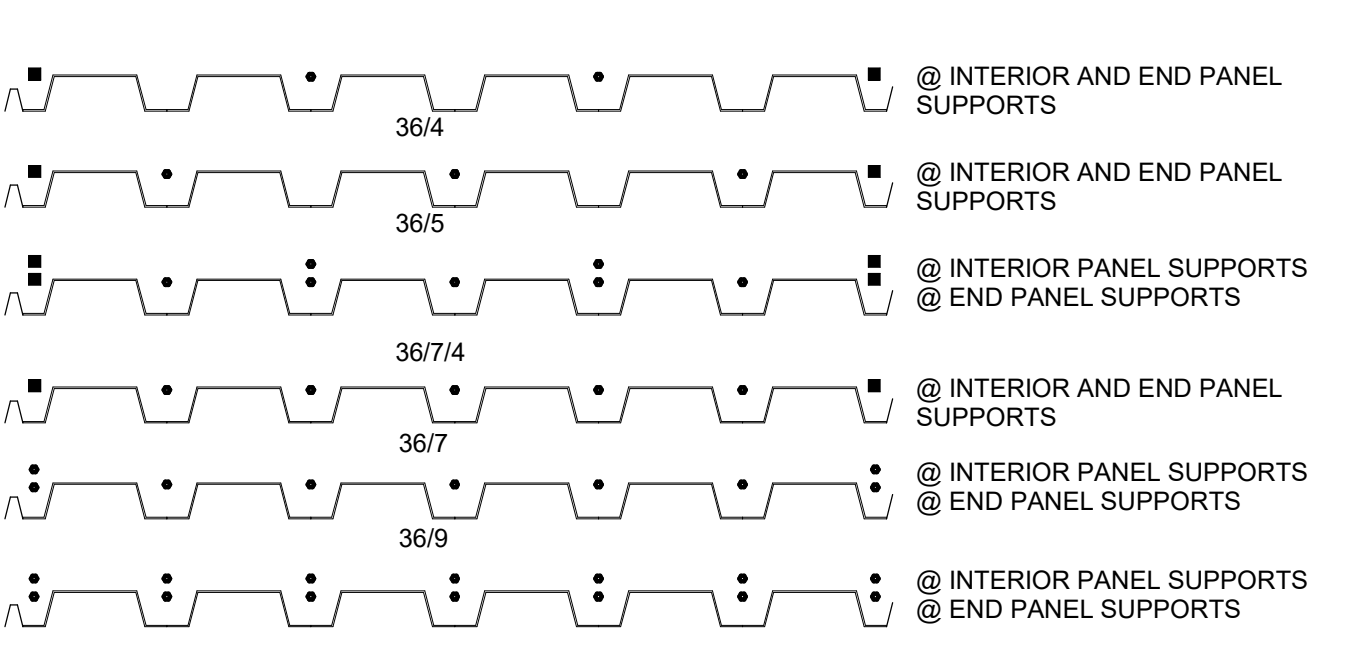

- INDICATES LOCATION OF ARC SPOT WELD, POWER ACTUATED FASTENER, OR SCREW AS INDICATED IN THE ATTACHMENT SCHEDULE.
- INDICATES LOCATION OF ARC SEAM WELD, POWER ACTUATED FASTENER, OR SCREW AS INDICATED IN THE ATTACHMENT SCHEDULE.
- NOTES:**
- ATTACHMENT PATTERNS SHOWN ARE FOR WELDED ATTACHMENTS. IF CONTRACTOR DESIRES TO USE SCREWS, MECHANICAL FASTENERS, OR OTHER MEANS OF ATTACHMENT, CONTRACTOR MUST SUBMIT DOCUMENTATION THAT CLEARLY SHOWS THAT PROPOSED ATTACHMENT METHODS MEET OR EXCEED ALLOWABLE DIAPHRAGM SHEAR STRENGTHS.
  - ARC SPOT WELDS SHALL HAVE AN EFFECTIVE FUSION DIAMETER OF AT LEAST 1/2 INCH.
  - ARC SEAM WELDS SHALL HAVE AN EFFECTIVE FUSION WIDTH OF AT LEAST 3/8 INCH BY 1 INCH LONG.
  - ARC SPOT WELDS MAY BE ELIMINATED WHERE THEY COINCIDE WITH STEEL HEADED STUD ANCHORS.
  - TOP SEAM WELDS SHALL BE AT LEAST 1 1/2 INCHES LONG. THE WELD MUST ENGAGE THE TOP OF THE INNER (MALE) LEG.

**WELLINGTON CITY**

ADMINISTRATION AND PUBLIC SAFETY BLDG

JDE No.2509-014

SUBMITTAL

**FOR BIDDING ONLY**

**REVISIONS**

NO.	DATE	DESCRIPTION
1	05/22/26	ADDENDUM NO.1

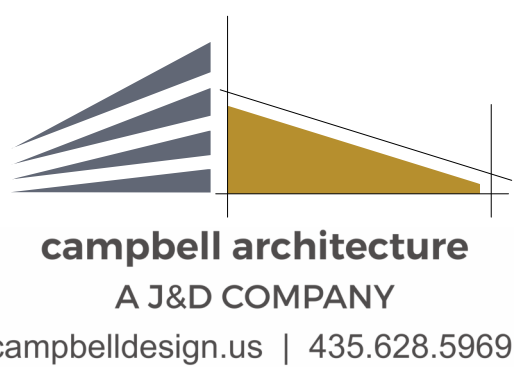

STRUCTURAL SCHEDULES

S-601

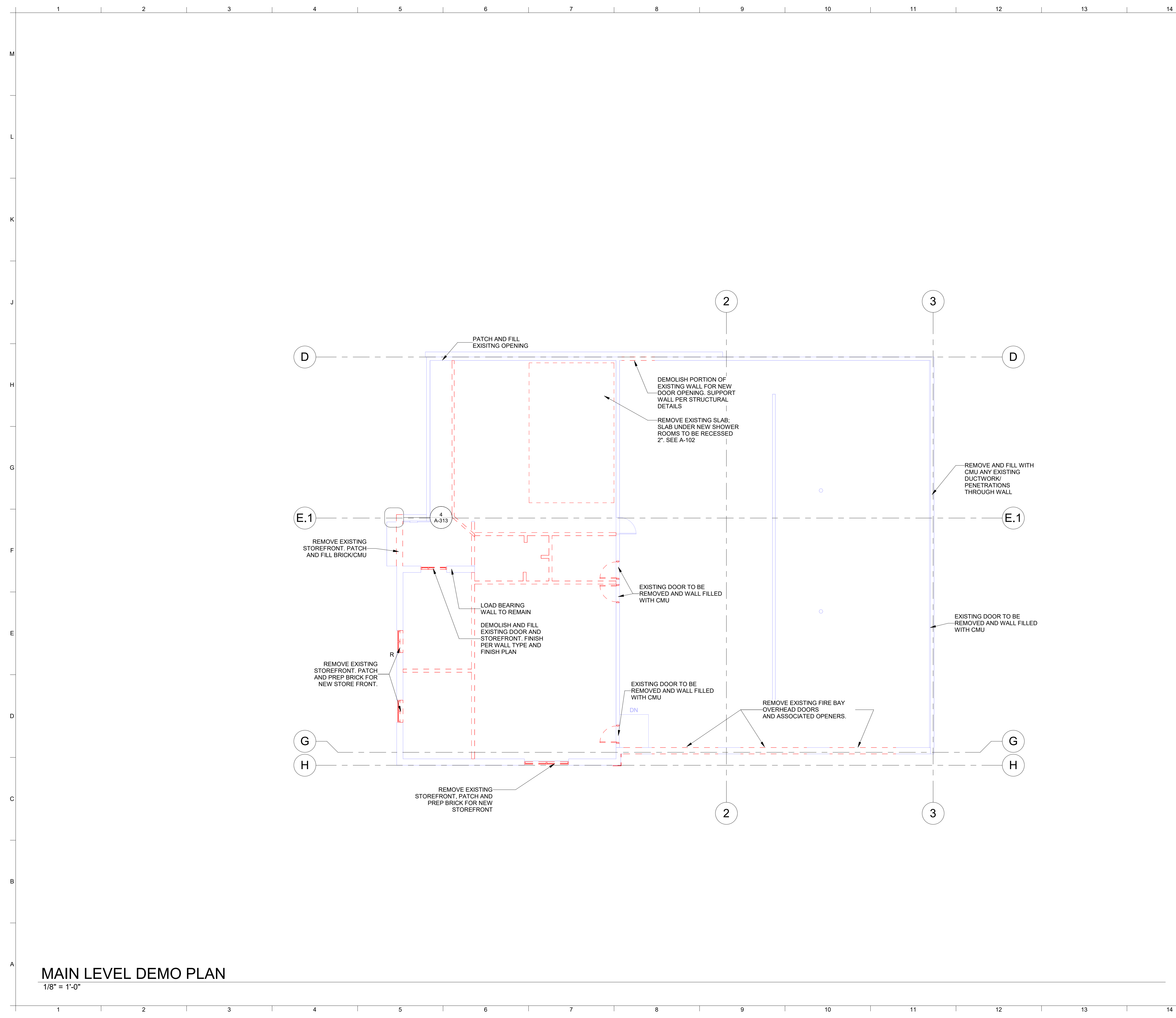

**DEMOLITION GENERAL NOTES**

1. CONTRACTOR TO NOTIFY ARCHITECT AND OWNER IF HAZARDOUS MATERIALS ARE ENCOUNTERED
2. CONFORM TO APPLICABLE REGULATOR PROCEDURES WHEN DISCOVERING HAZARDOUS OR CONTAMINATED MATERIALS
3. CONFORM TO APPLICABLE CODE FOR DEMOLITION OF STRUCTURES, SAFETY OF ADJACENT STRUCTURES, DUST CONTROL AND DISPOSAL OF MATERIALS.
4. NOTIFY AFFECTED UTILITY COMPANIES BEFORE STARTING WORK AND COMPLY WITH THEIR REQUIREMENTS
5. DEMOLISH EXISTING WORK IN AN ORDERLY AND CAREFUL MANNER AS REQUIRED TO ACCOMMODATE NEW WORK, PREVENT MOVEMENT OR SETTLEMENT OF STRUCTURE, PROVIDE BRACING AND / OR SHORING AS REQUIRED TO MAINTAIN SAFETY
6. COORDINATE ALL DEMOLITION WORK WITH OWNER AS NECESSARY
7. GENERAL CONTRACTOR TO NOTIFY OWNER REPRESENTATIVE AND ARCHITECT OF ANY DISCREPANCIES OR IRREGULARITIES DISCOVERED DURING CONSTRUCTION
8. GENERAL CONTRACTOR TO COORDINATE WITH OWNER SCHEDULE AND TIMINGS OF DEMOLITION WORK. CONTRACTOR TO PROVIDE AND INSTALL ALL TEMPORARY MEANS OF EGRESS, TEMPORARY LIGHTING AND SAFETY DEVICES IN ACCORDANCE WITH STATE AND LOCAL CODES
9. CONTRACTOR IS RESPONSIBLE FOR PATCHING AND REPAIRING FLOOR SLABS AND WALLS AFTER COMPLETION OF DEMOLITION AND PRIOR TO THE COMMENCEMENT OF NEW CONSTRUCTION.
10. CONTRACTOR IS TO PATCH, REPAIR AND LEVEL FLOOR SLAB TO RECEIVE NEW WORK AND INFORM OWNERS REPRESENTATIVE OF ANY IRREGULARITIES
11. DEMOLITION CONTRACTOR SHALL REMOVE ALL FLOOR COVERING AND/OR FINISHES, UNDERLAYMENT, GLUE AND ANY OTHER ADHESIVE AS NOTED ON DEMO PLAN. CONTRACTOR SHALL PREPARE THE FLOOR SLAB FOR THE NEW FLOORING FINISHES OR COVERINGS AS SPECIFIED BY THE MANUFACTURER
12. DEMOLITION CONTRACTOR SHALL COORDINATE WALL MECHANICAL, ELECTRICAL AND PLUMBING DEMOLITION WORK WITH PLANS PRIOR TO THE COMMENCEMENT OF ANY WORK AND COORDINATE THEIR WORK WITH THE GENERAL CONTRACTOR AND OTHER SUB-CONTRACTORS AS NECESSARY
13. ALL MECHANICAL, ELECTRICAL AND PLUMBING FIXTURES, EQUIPMENT AND/OR DEVICES SCHEDULED TO BE REMOVED SHALL BE DISCONNECTED AT THE SOURCE UNLESS NOTED OR DIRECTED OTHERWISE. COORDINATE ALL WORK WITH MECHANICAL, ELECTRICAL AND PLUMBING PLANS.
14. REFER TO SPECS FOR ANY OTHER INFORMATION

**DEMOLITION NOTES:**

1. ALL EXISTING FLOOR FINISHES TO BE DEMOLISHED. PATCH AND FILL CONCRETE TO PREP FOR NEW FLOORING.
2. ALL EXISTING ELECTRICAL, MECHANICAL, AND PLUMBING SYSTEMS TO BE DEMOLISHED AS PER NOTED ON MPE PLANS.
3. ALL EXISTING INTERIOR DOORS AND WALLS TO BE REMOVED UNLESS NOTED OTHERWISE.
4. ALL EXISTING LAY IN AND GYP CEILINGS TO BE DEMOLISHED.

**PHASES**

- EXISTING
- DEMOLISHED
- NEW CONSTRUCTION
- FUTURE

**WELLINGTON CITY**  
 ADMINISTRATION AND PUBLIC SAFETY BLDG  
 JDE No.2509-014  
 SUBMITTAL  
**FOR BIDDING ONLY**

REVISIONS

NO.	DATE	DESCRIPTION
1	05/22/20	ADDENDUM NO.1

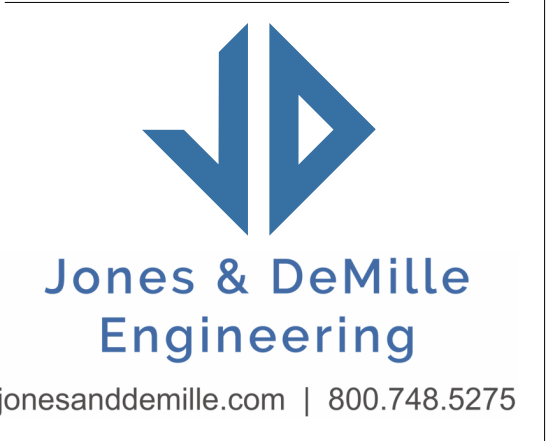
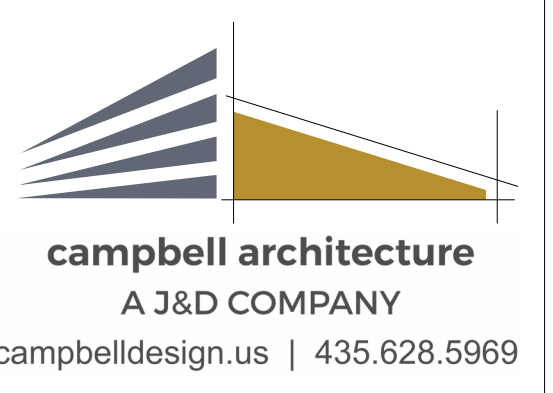
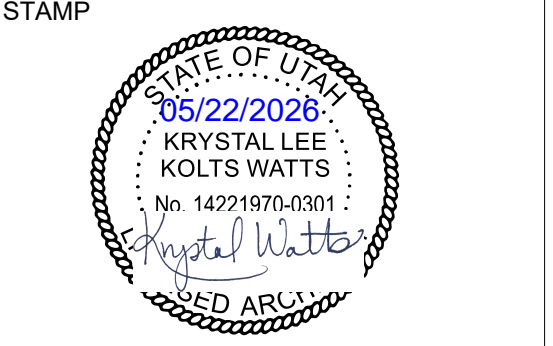

DEMOLITION PLAN  
**AD-101**

File Path: \\adses01\docs\2509-014 Wellington City Office\2509-014\_Wellington City Office.ctb  
 Print Date: 5/22/2020 1:50:03 PM

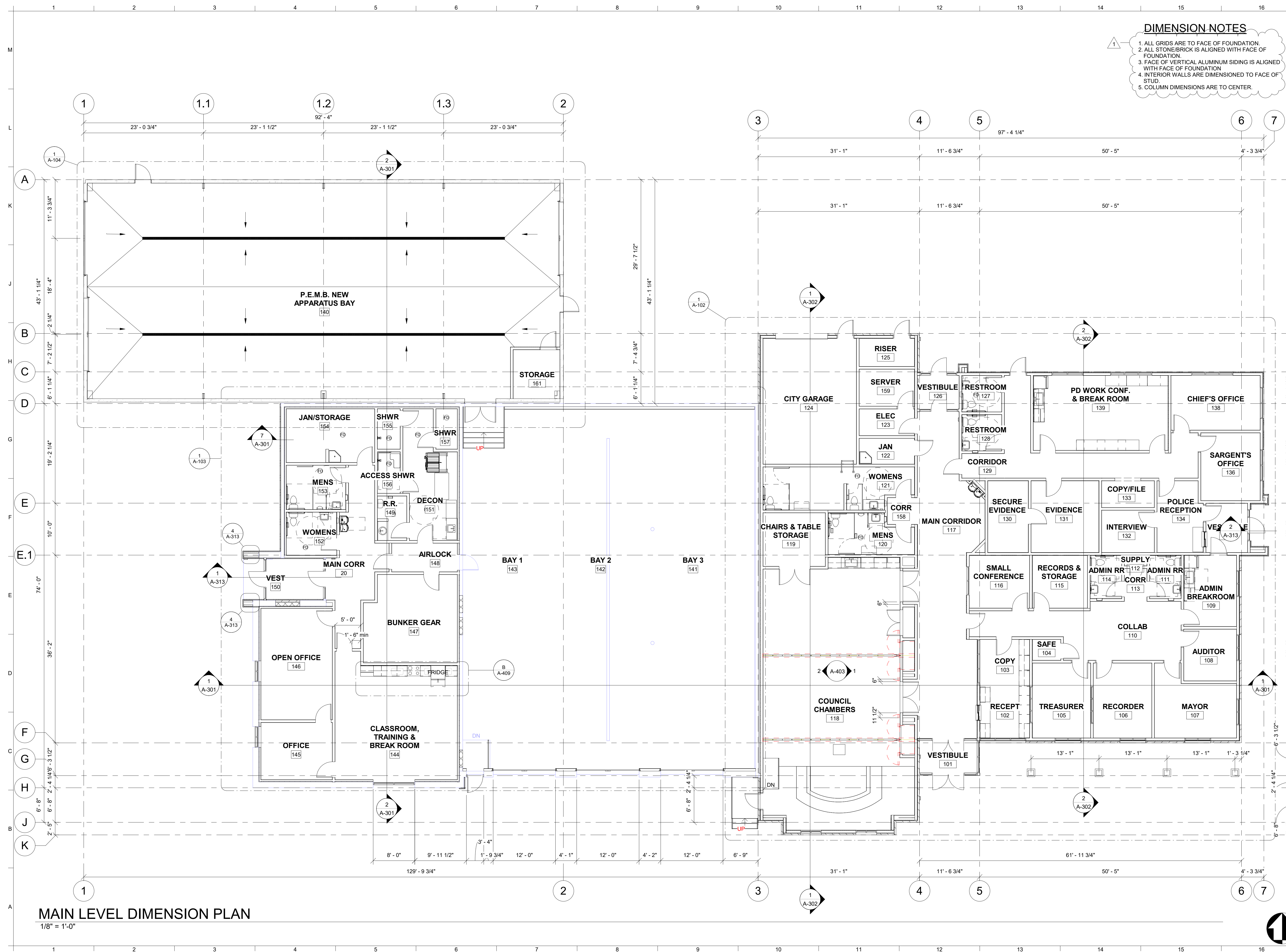

**DIMENSION NOTES**

1. ALL GRIDS ARE TO FACE OF FOUNDATION.
2. ALL STONE/BRICK IS ALIGNED WITH FACE OF FOUNDATION.
3. FACE OF VERTICAL ALUMINUM SIDING IS ALIGNED WITH FACE OF FOUNDATION.
4. INTERIOR WALLS ARE DIMENSIONED TO FACE OF STUD.
5. COLUMN DIMENSIONS ARE TO CENTER.

**WELLINGTON CITY**

ADMINISTRATION AND PUBLIC SAFETY BLDG

JDE No.2509-014

SUBMITTAL

**FOR BIDDING ONLY**

REVISIONS

NO.	DATE	DESCRIPTION
1	05/22/20	ADDENDUM NO.1

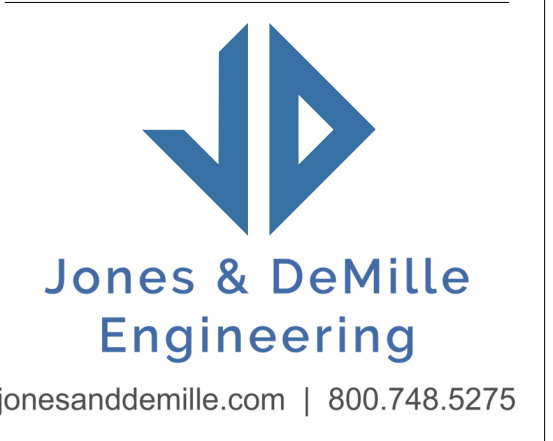
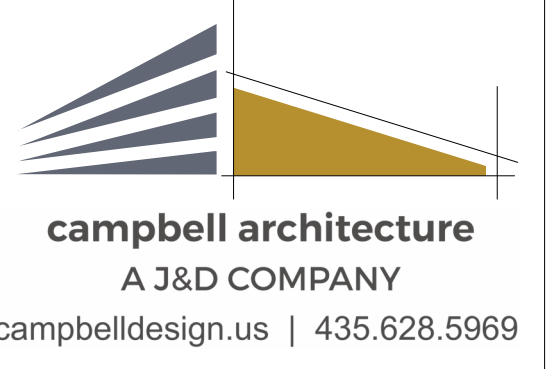
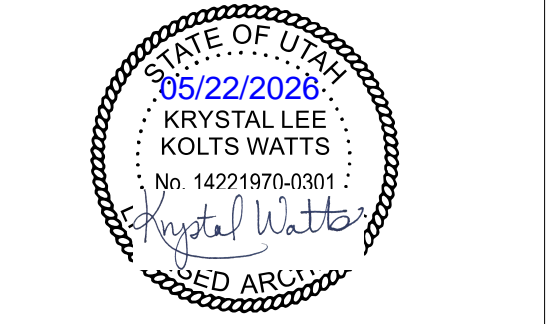

**MAIN LEVEL DIMENSION PLAN**  
1/8" = 1'-0"

**DIMENSION PLAN - OVERALL FLOOR PLAN**

**A-101**

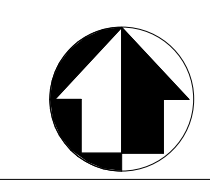

File Path: \\ussd01\apps\2509-014 Wellington City Office\2509-014\_Wellington City Office.rvt  
Issue Date: 02/22/2020 1:50:05 PM

**DIMENSION NOTES**

1. ALL GRIDS ARE TO FACE OF FOUNDATION.
2. ALL STONE/BRICK IS ALIGNED WITH FACE OF FOUNDATION.
3. FACE OF VERTICAL ALUMINUM SIDING IS ALIGNED WITH FACE OF FOUNDATION.
4. INTERIOR WALLS ARE DIMENSIONED TO FACE OF STUD.
5. COLUMN DIMENSIONS ARE TO CENTER.

**WELLINGTON CITY**

**ADMINISTRATION AND PUBLIC SAFETY BLDG**

**JDE No.2509-014**

SUBMITTAL

**FOR BIDDING ONLY**

REVISIONS

NO.	DATE	DESCRIPTION
1	05/22/20	ADDENDUM NO.1

STAMP

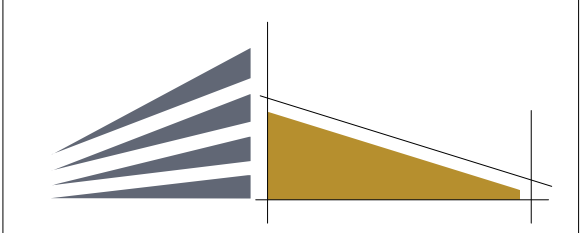
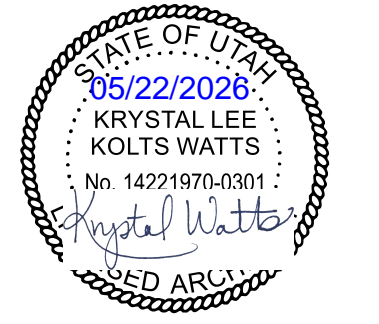

**campbell architecture**  
A J&D COMPANY  
campbelldesign.us | 435.628.5969

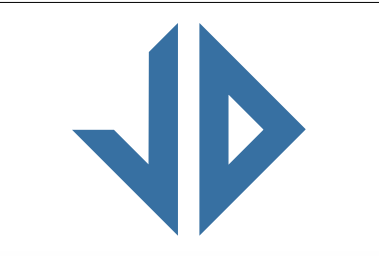

**Jones & DeMille Engineering**  
jonesanddemille.com | 800.748.5275

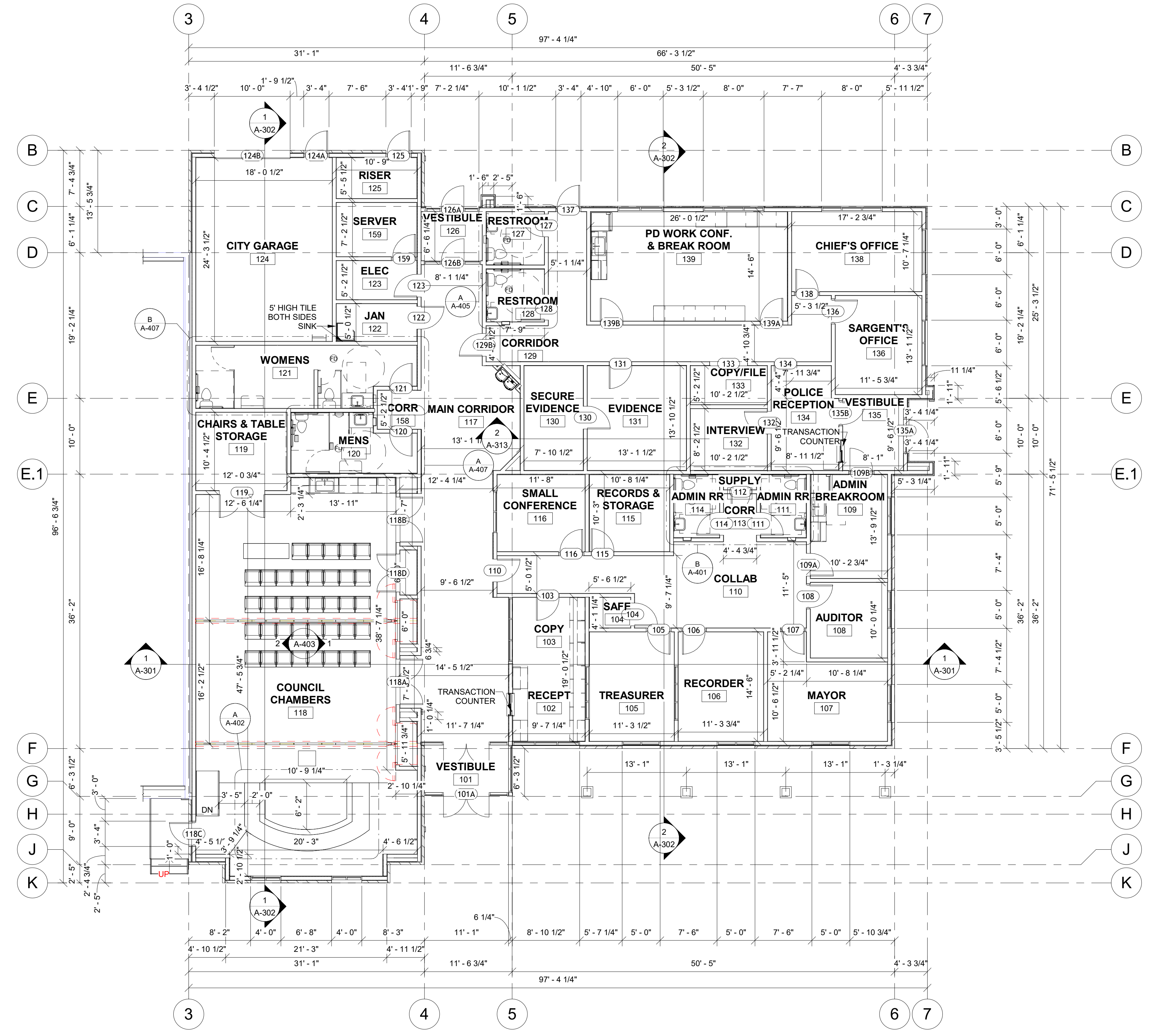

**CITY OFFICES AND POLICE DEPARTMENT DIMENSION PLAN**

1/8" = 1'-0"

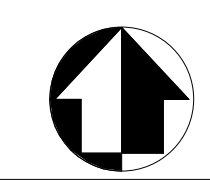

**A-102**

DIMENSION PLAN - CITY OFFICES & POLICE DEPT.

File Path: \\ussdsk001\2509-014 Wellington City Offices\2509-014 Wellington City Offices.rvt Issue Date: 02/22/2020 1:50:08 PM

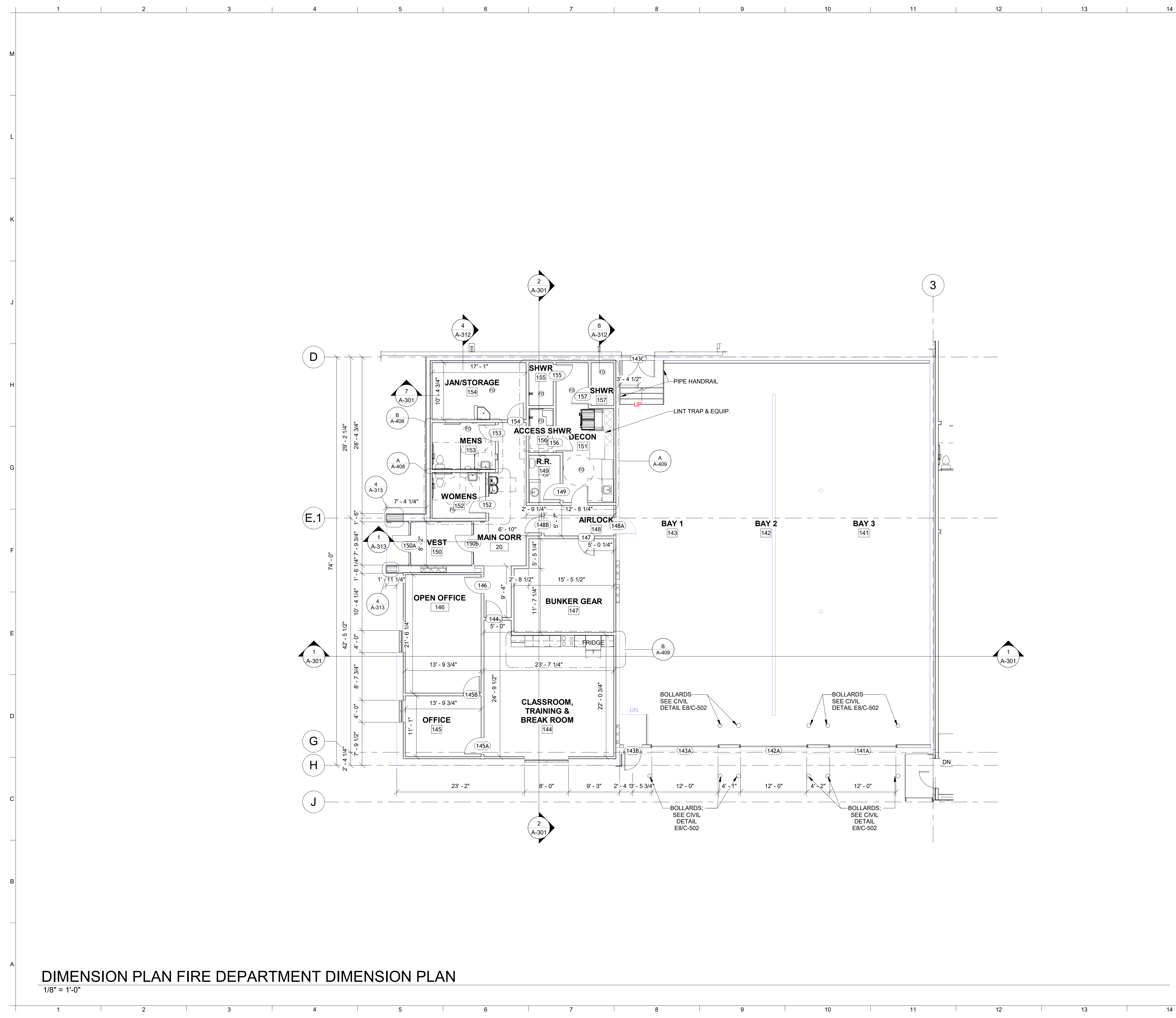

**DIMENSION NOTES**

1. ALL GRIDS ARE TO FACE OF FOUNDATION.
2. ALL STONE/BRICK IS ALIGNED WITH FACE OF FOUNDATION.
3. FACE OF VERTICAL ALUMINUM SIDING IS ALIGNED WITH FACE OF FOUNDATION.
4. INTERIOR WALLS ARE DIMENSIONED TO FACE OF STUD.
5. COLUMN DIMENSIONS ARE TO CENTER.

**WELLINGTON CITY**

**ADMINISTRATION AND PUBLIC SAFETY BLDG**

JDE No.2509-014

SUBMITTAL  
**FOR BIDDING ONLY**

REVISIONS

NO.	DATE	DESCRIPTION
1	05/22/2028	ADDENDUM NO.1

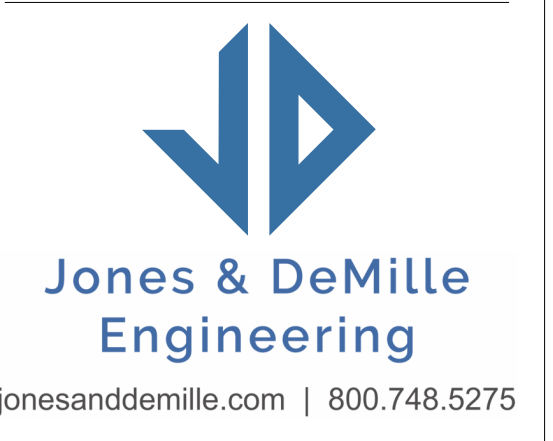
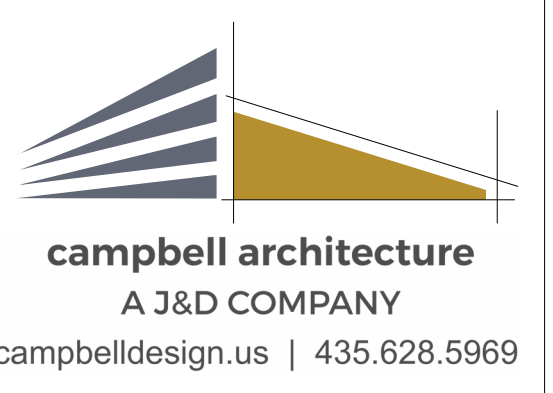
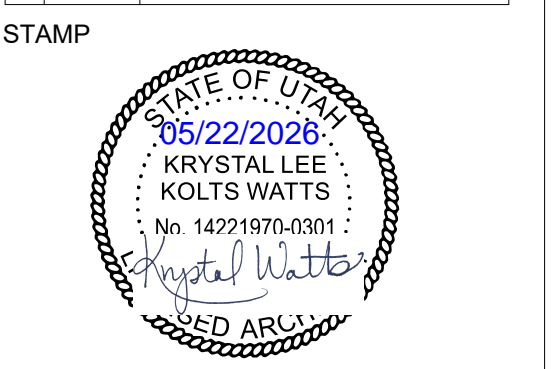

**DIMENSION PLAN FIRE DEPARTMENT DIMENSION PLAN**  
1/8" = 1'-0"

DIMENSION PLAN - FIRE DEPARTMENT

**A-103**

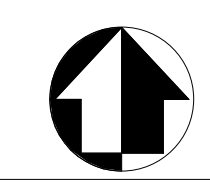

File Path: \\ussdsk02\2509-014 Wellington City Office\2509-014 Wellington City Office.rvt

**DIMENSION NOTES**

1. ALL GRIDS ARE TO FACE OF FOUNDATION.
2. ALL STONE/BRICK IS ALIGNED WITH FACE OF FOUNDATION.
3. FACE OF VERTICAL ALUMINUM SIDING IS ALIGNED WITH FACE OF FOUNDATION.
4. INTERIOR WALLS ARE DIMENSIONED TO FACE OF STUD.
5. COLUMN DIMENSIONS ARE TO CENTER.

**WELLINGTON CITY**

**ADMINISTRATION AND PUBLIC SAFETY BLDG**

**JDE No.2509-014**

SUBMITTAL  
**FOR BIDDING ONLY**

REVISIONS

NO.	DATE	DESCRIPTION
1	05/22/20	ADDENDUM NO.1

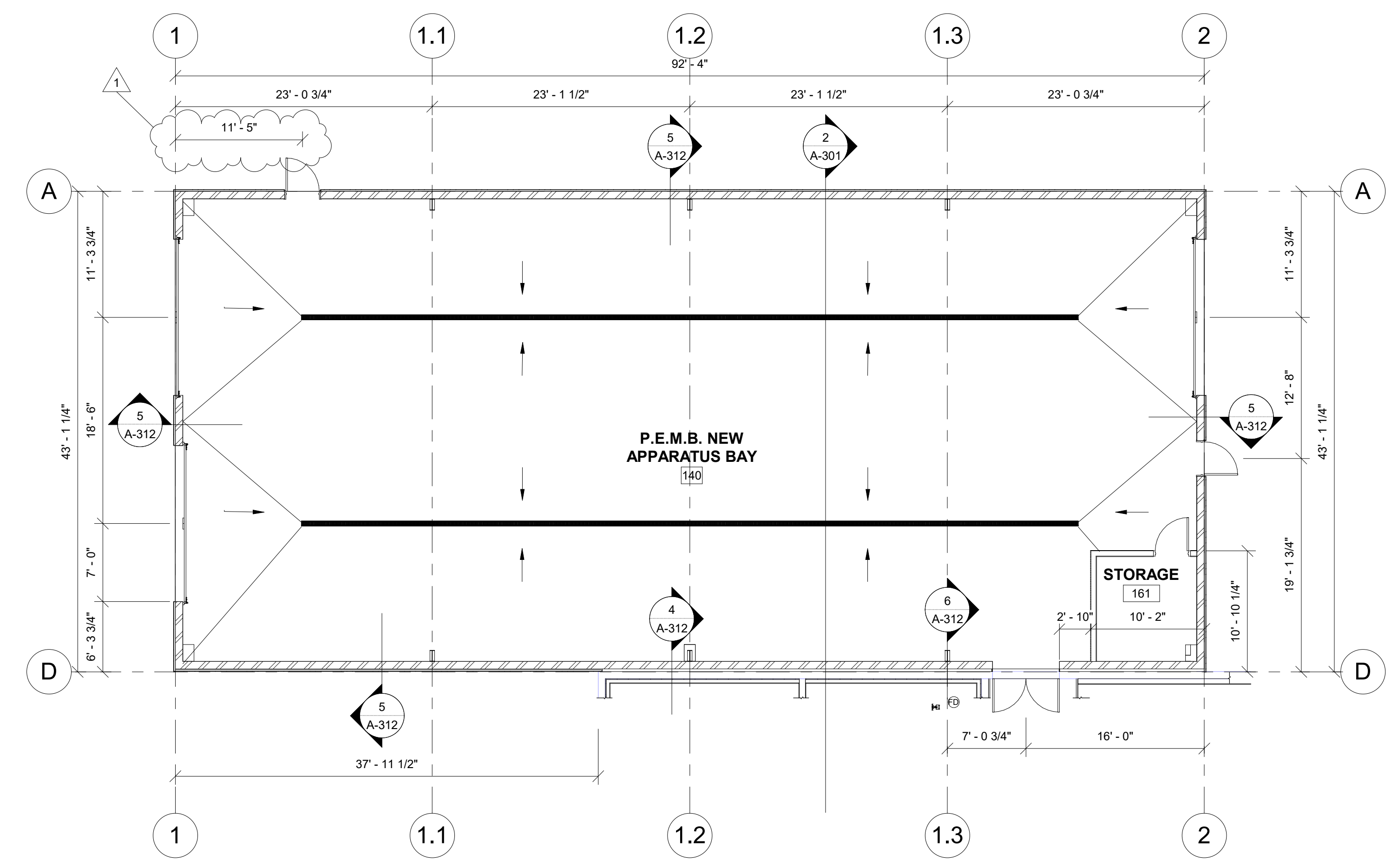
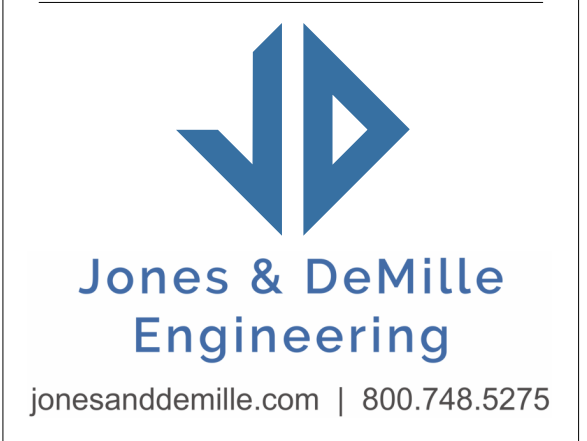
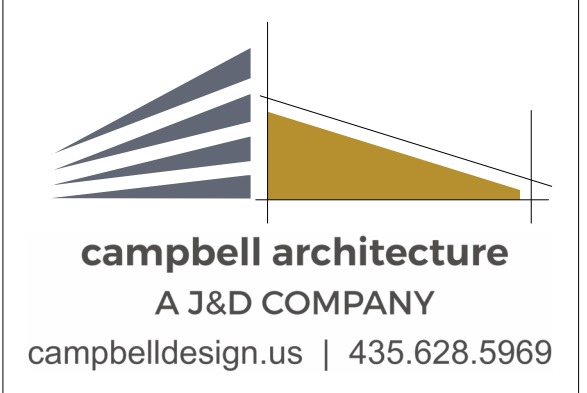
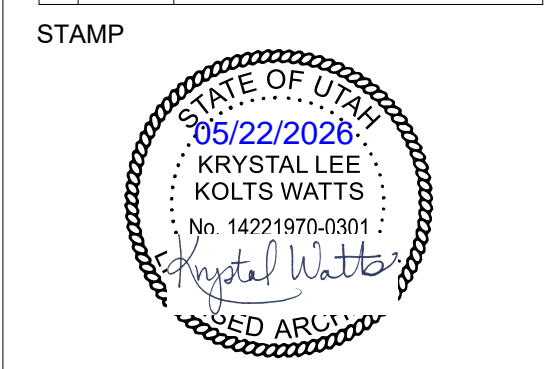

**APPARATUS BAY DIMENSION PLAN**

1/8" = 1'-0"

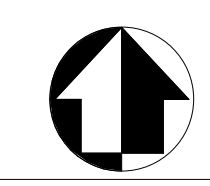

DIMENSION PLAN - APPARATUS BAY

**A-104**

File Path: \\ussdsk001\2509-014 Wellington City Office\2509-014 Wellington City Office.rvt  
Issue Date: 02/22/2020 1:50:07 PM

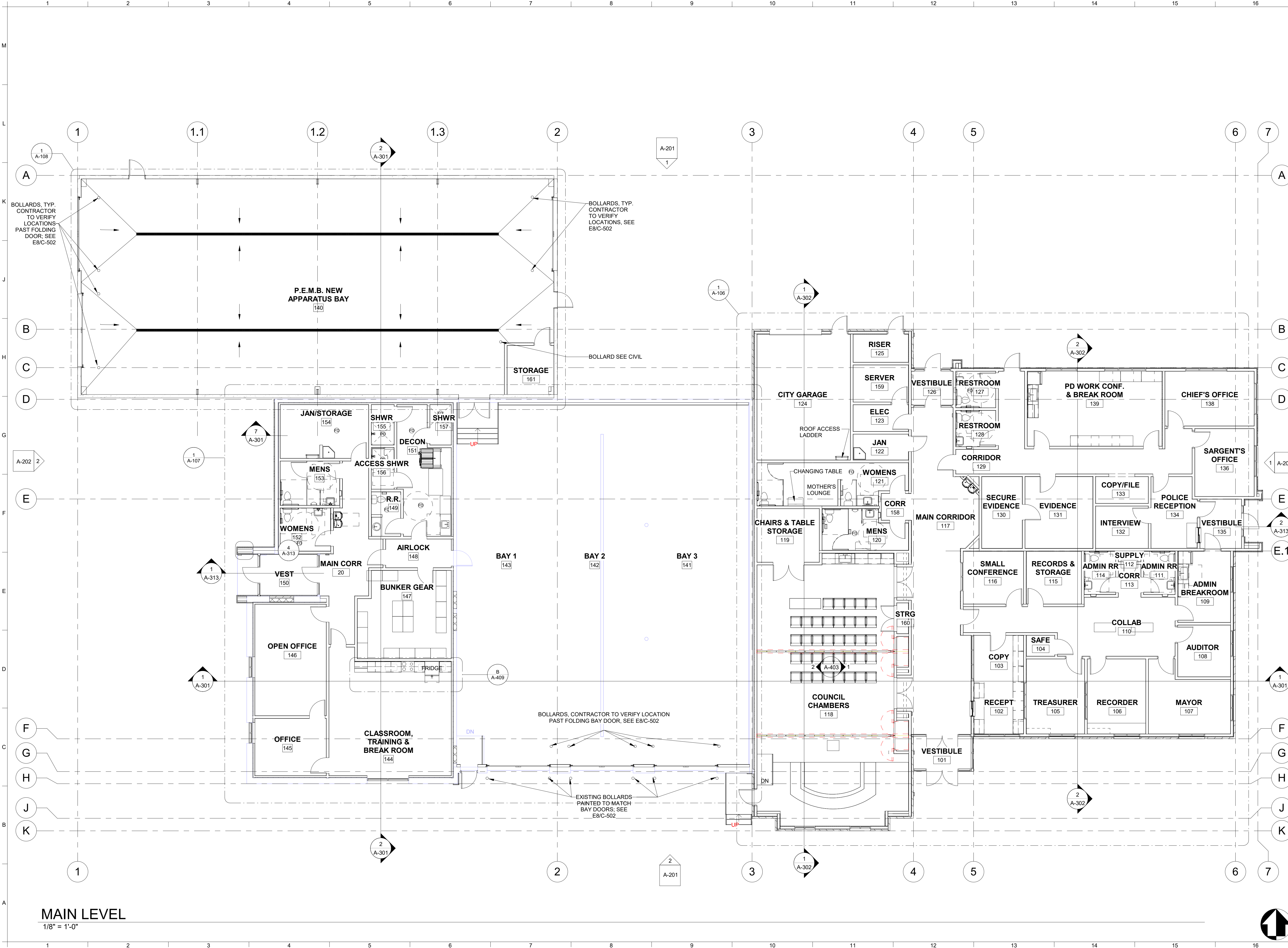

**MAIN LEVEL**  
1/8" = 1'-0"

**WELLINGTON CITY**

ADMINISTRATION AND  
PUBLIC SAFETY BLDG

JDE No.2509-014

SUBMITTAL  
**FOR BIDDING ONLY**

NO.	DATE	DESCRIPTION
1	05/22/20	ADDENDUM NO.1

STAMP

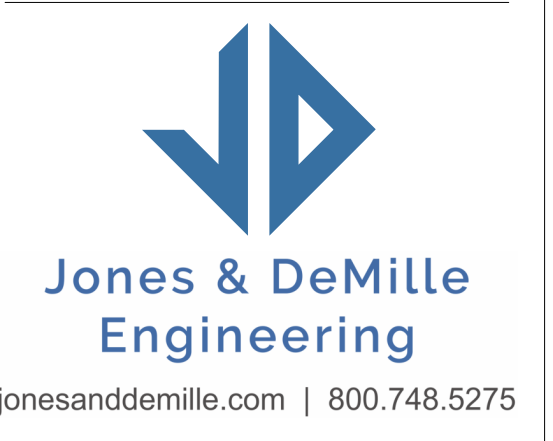
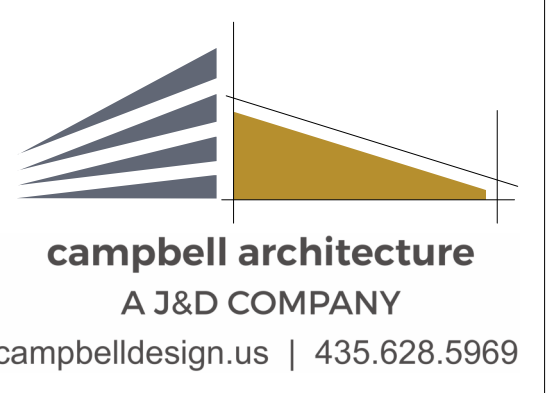
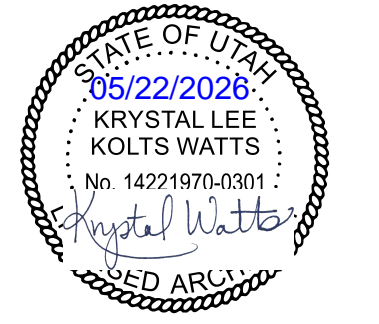

FLOOR PLAN - OVERALL

**A-105**

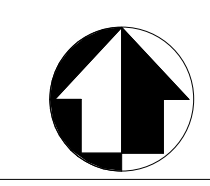

File Path: \\ussd01\apps\2509-014 Wellington City Office\2509-014\_Wellington City Office.rvt  
Issue Date: 02/22/2020 1:50:09 PM

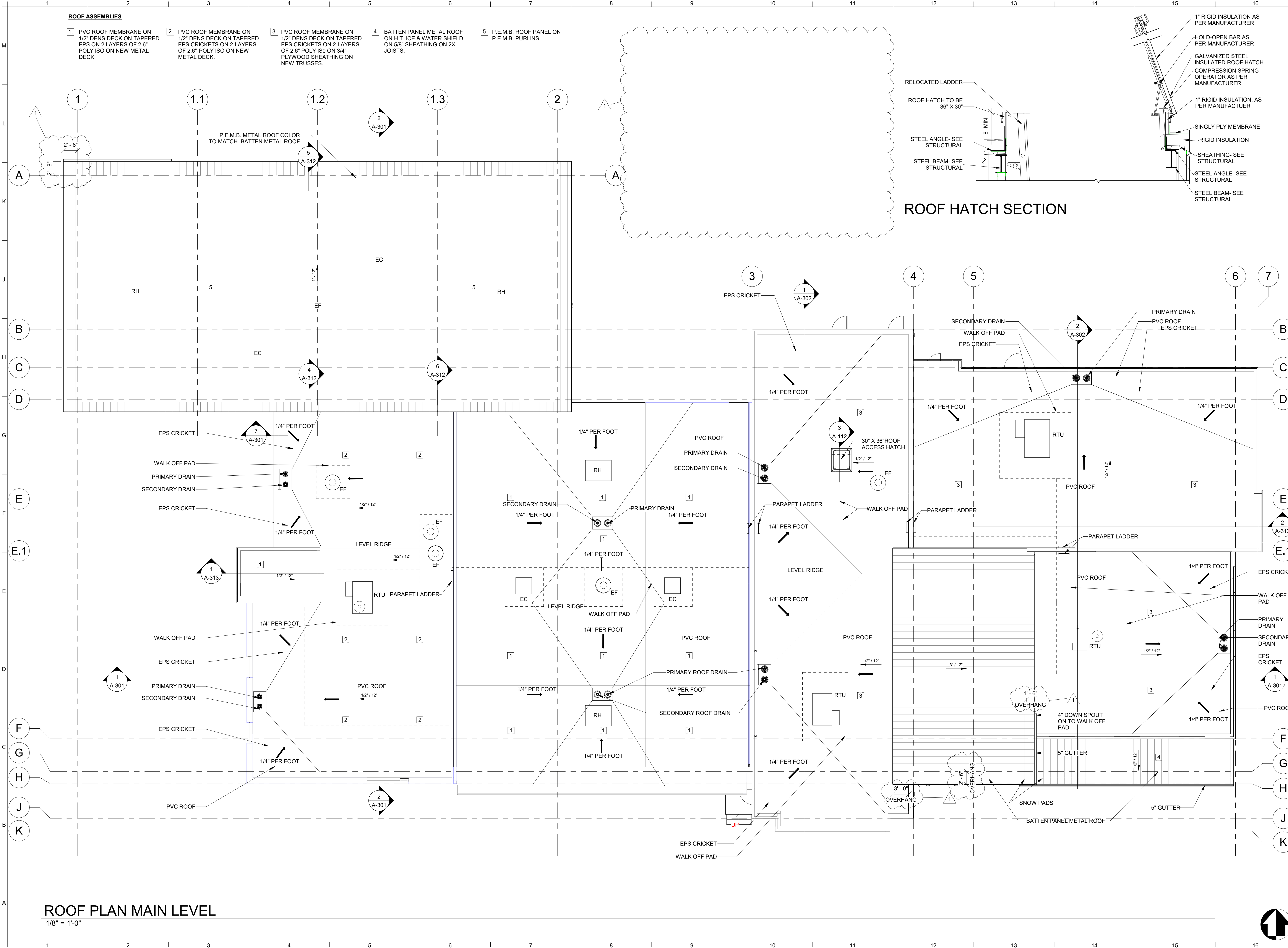

**WELLINGTON CITY**

ADMINISTRATION AND PUBLIC SAFETY BLDG

JDE No.2509-014

SUBMITTAL

**FOR BIDDING ONLY**

REVISIONS

NO.	DATE	DESCRIPTION
1	05/22/28	ADDENDUM NO.1

STAMP

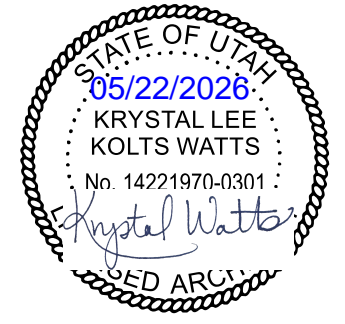

**campbell architecture**  
A J&D COMPANY  
campbelldesign.us | 435.628.5969

**Jones & DeMille Engineering**  
jonesanddemille.com | 800.748.5275

ROOF PLAN OVERALL

**A-112**

File Path: \\adses02\cadd\2509-014 Wellington City Office\2509-014 Wellington City Office.rvt

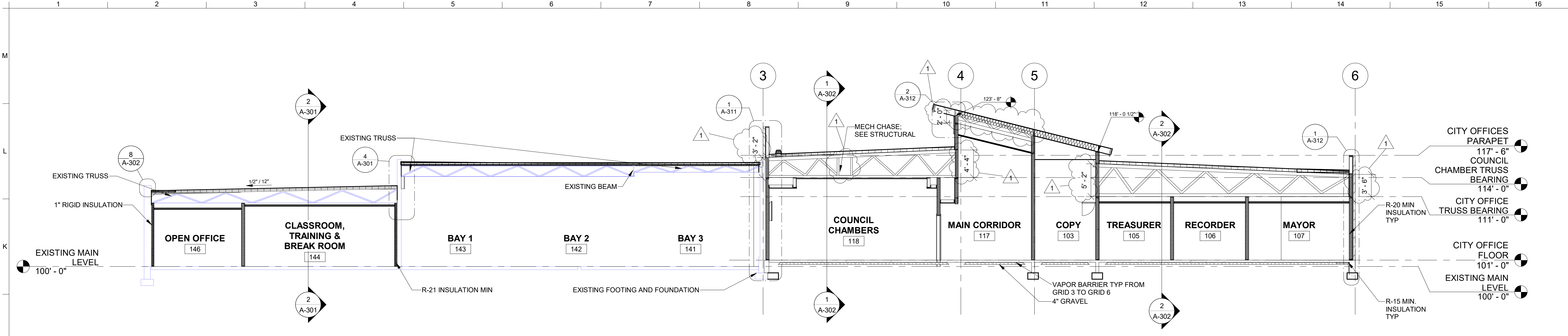

**1 EAST/WEST SECTION**  
1/8" = 1'-0"

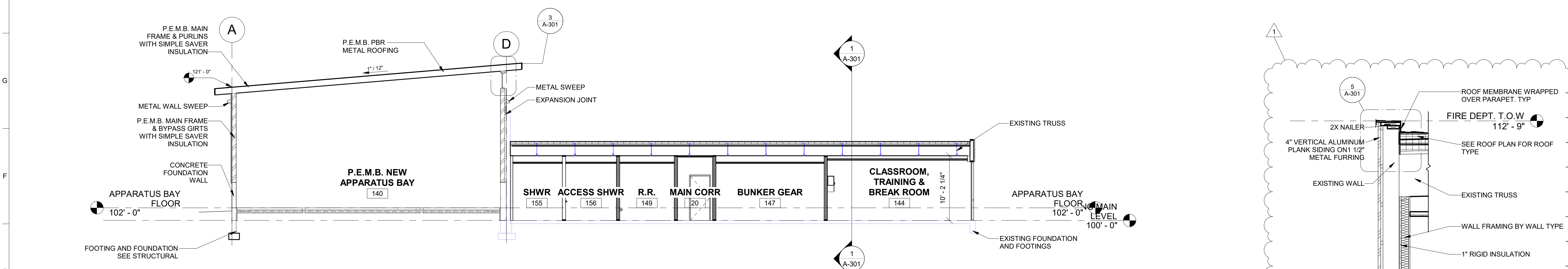

**2 NORTH/SOUTH SECTION 1**  
1/8" = 1'-0"

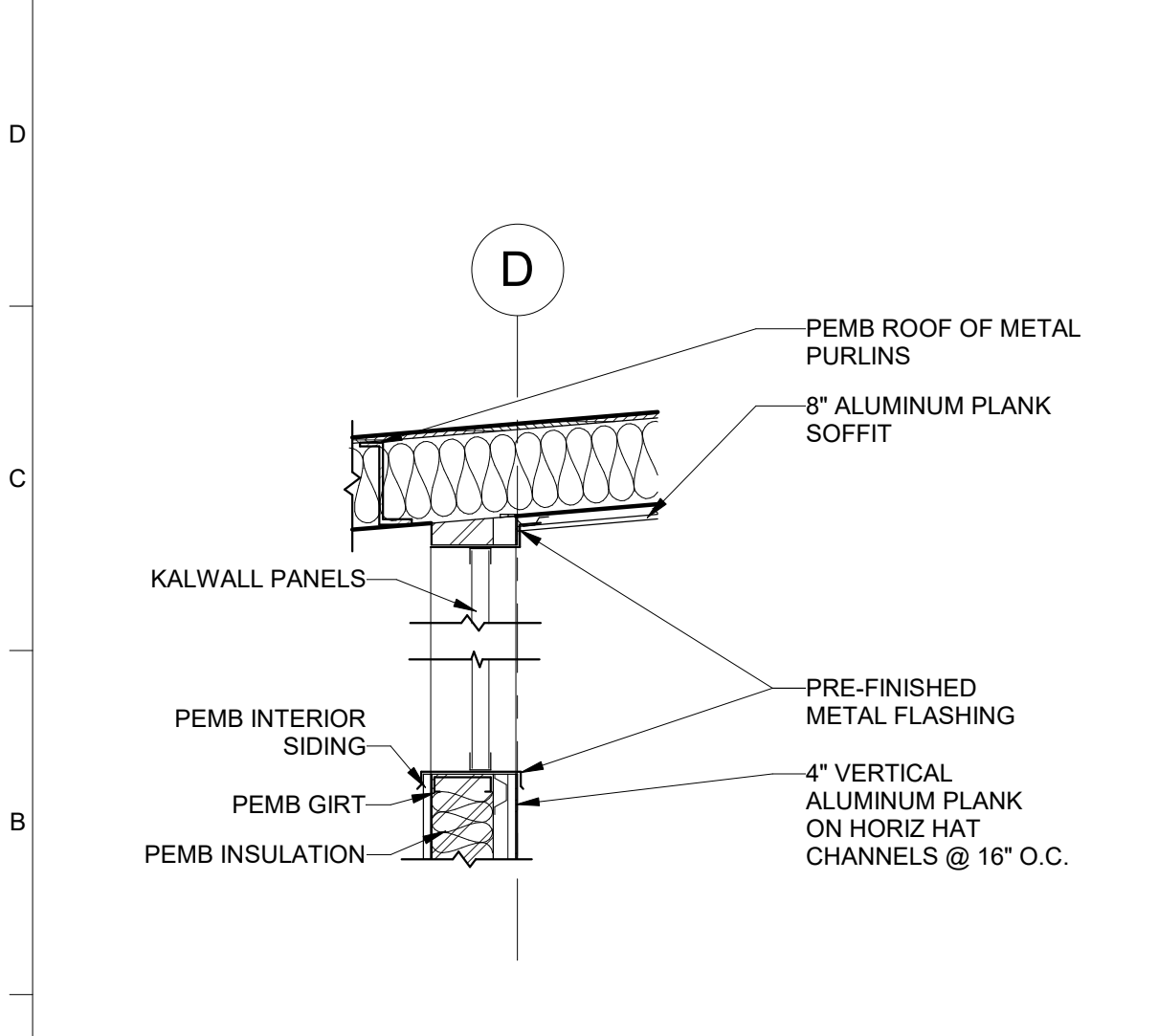

**3 CLEARSTORY DETAIL**  
1/2" = 1'-0"

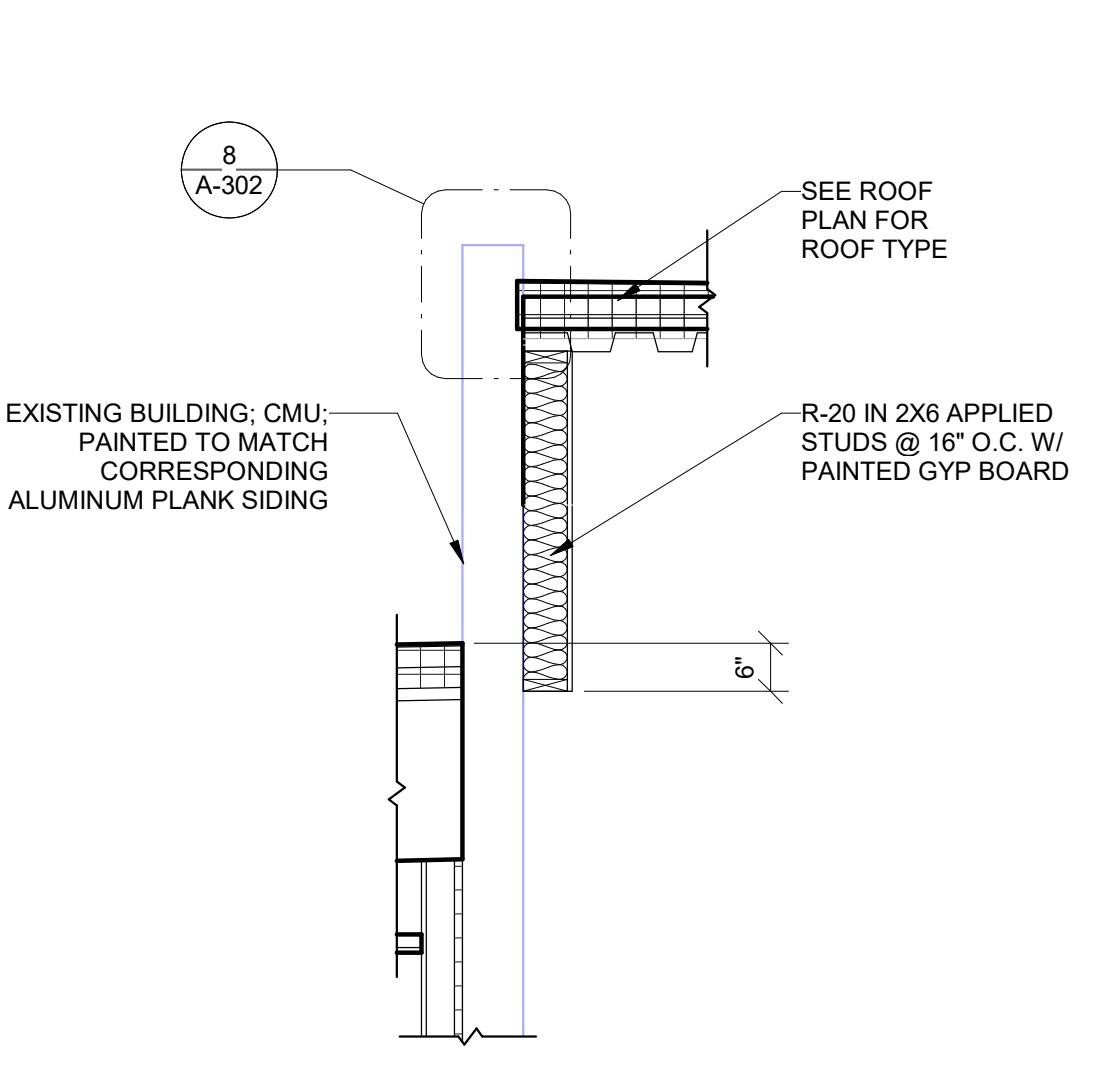

**4 WALL DETAIL**  
1/2" = 1'-0"

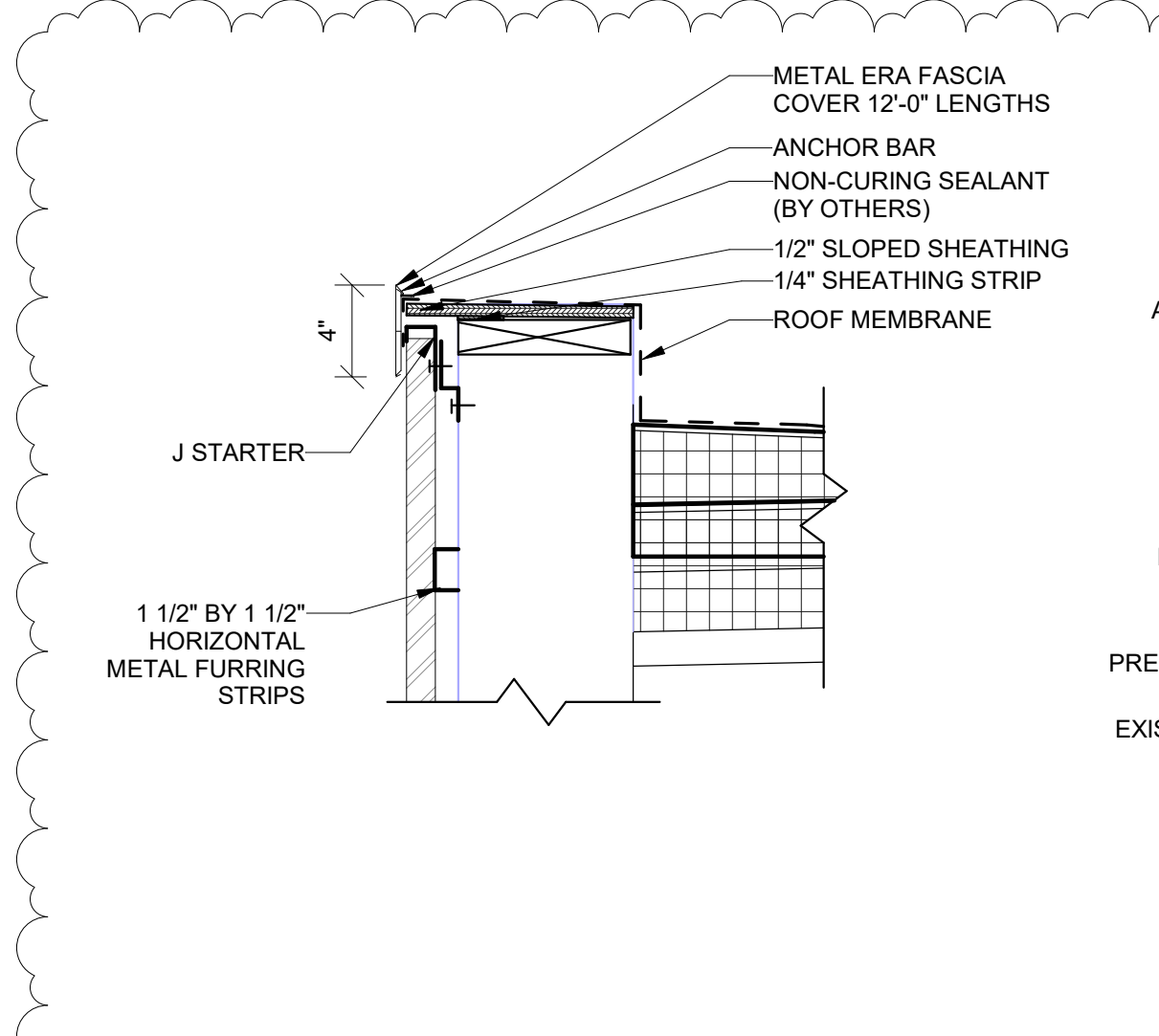

**5 DETAIL**  
1 1/2" = 1'-0"

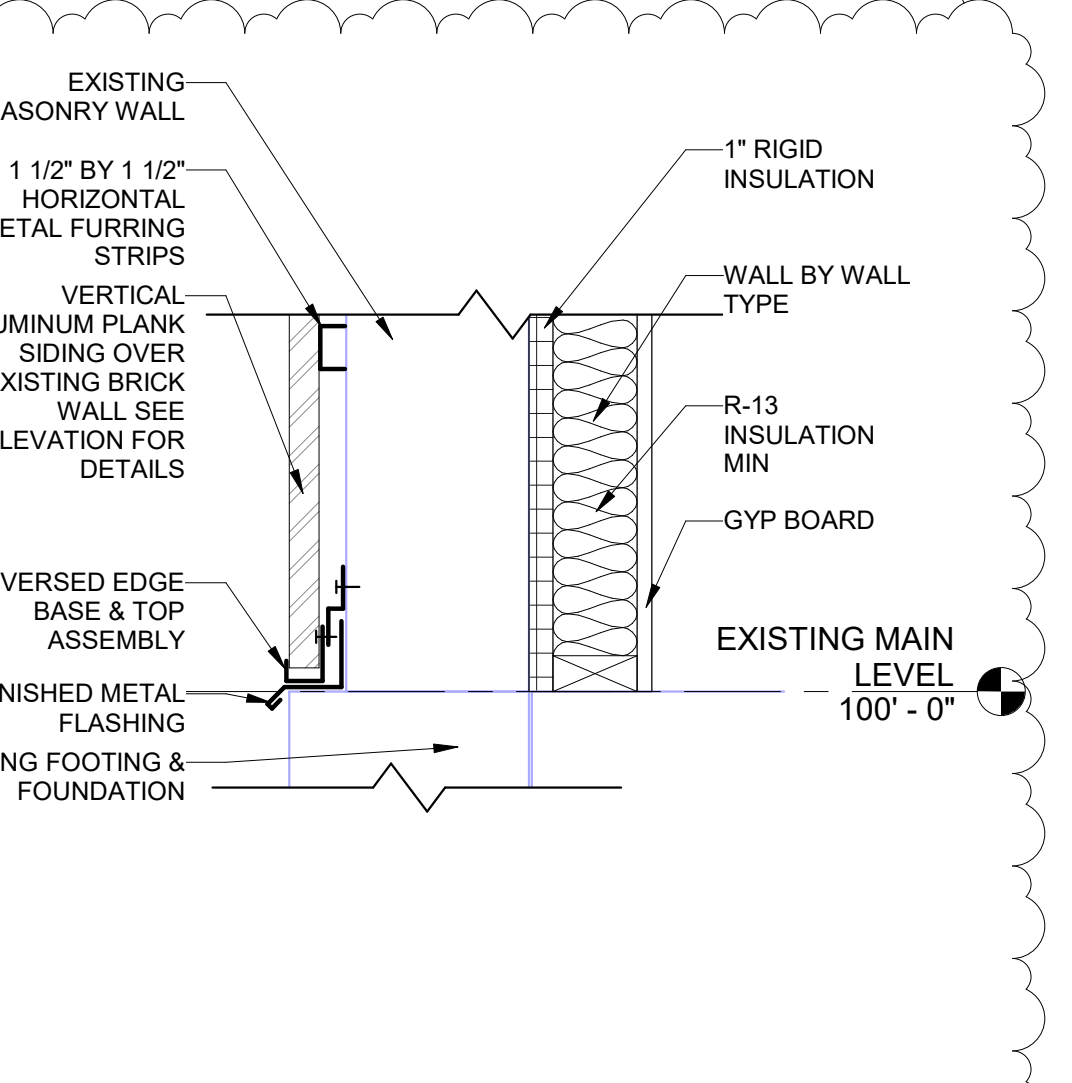

**6 DETAIL**  
1 1/2" = 1'-0"

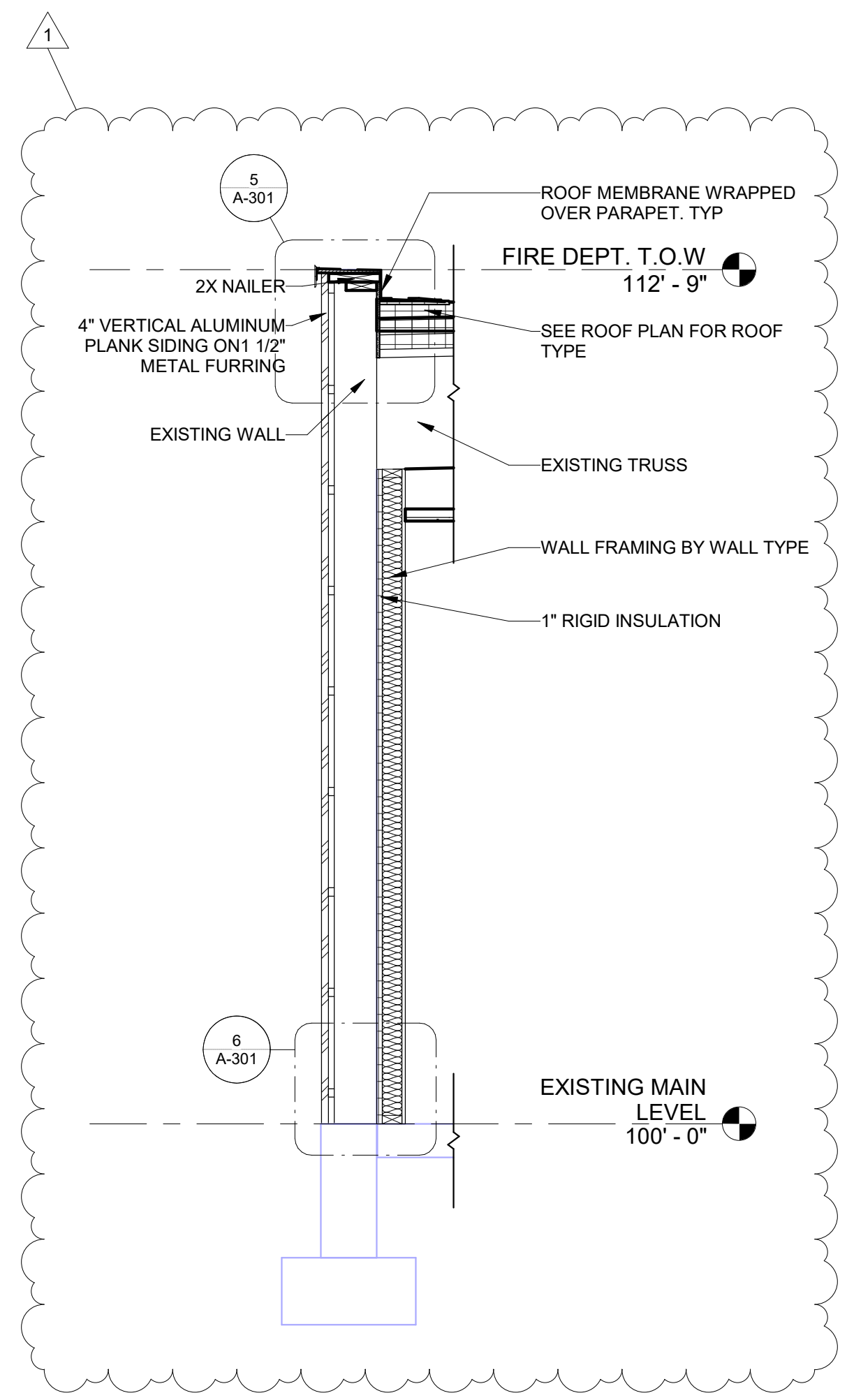

**7 WALL SECTION**  
1/2" = 1'-0"

**WELLINGTON CITY**

ADMINISTRATION AND PUBLIC SAFETY BLDG

JDE No.2509-014

SUBMITTAL

**FOR BIDDING ONLY**

NO.	DATE	DESCRIPTION
1	05/22/2028	ADDENDUM NO.1

REVISIONS

STAMP

**campbell architecture**  
A J&D COMPANY  
campbelldesign.us | 435.628.5969

**Jones & DeMille Engineering**  
jonesanddemille.com | 800.748.5275

NO.	DATE	DESCRIPTION
1	05/22/20	ADDENDUM NO.1

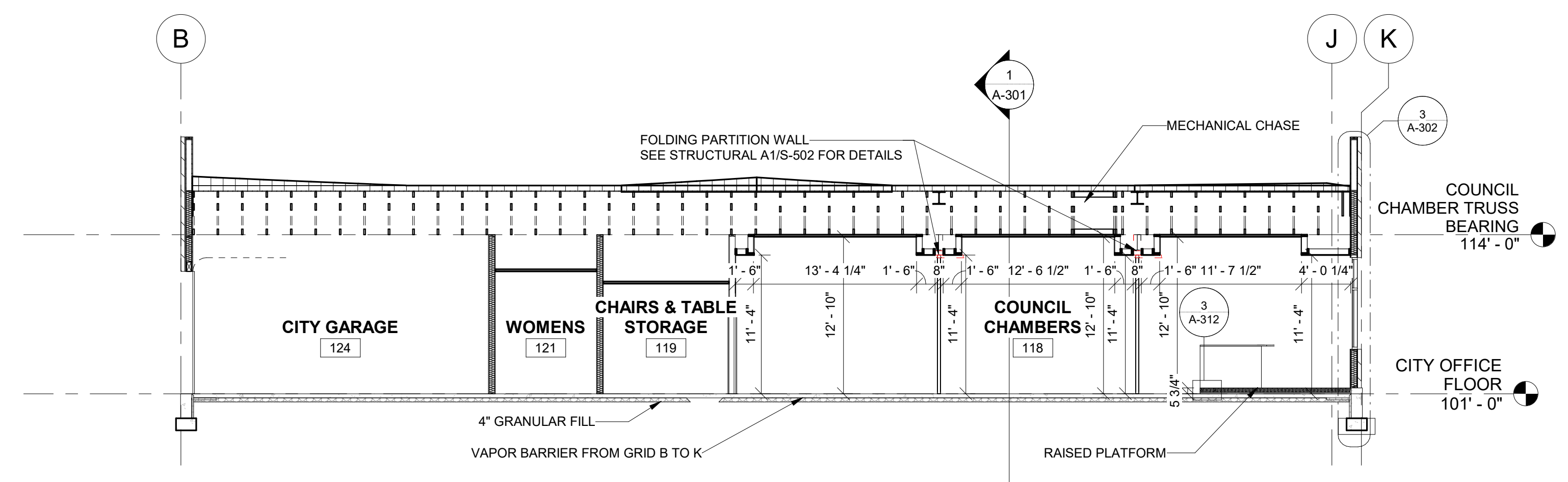
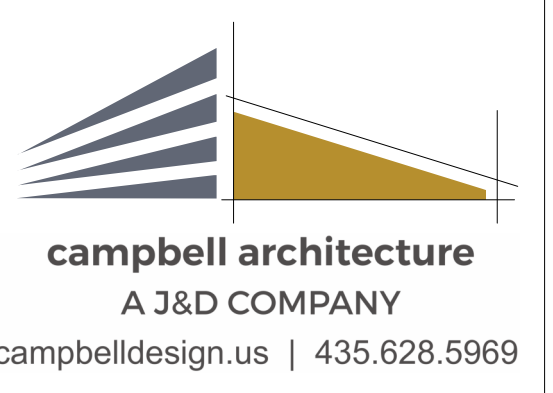
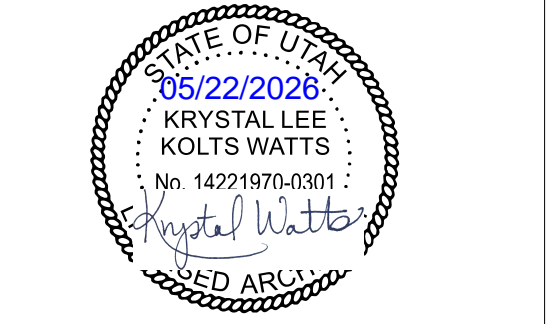

1 NORTH/SOUTH COUNCIL CHAMBER  
1/8" = 1'-0"

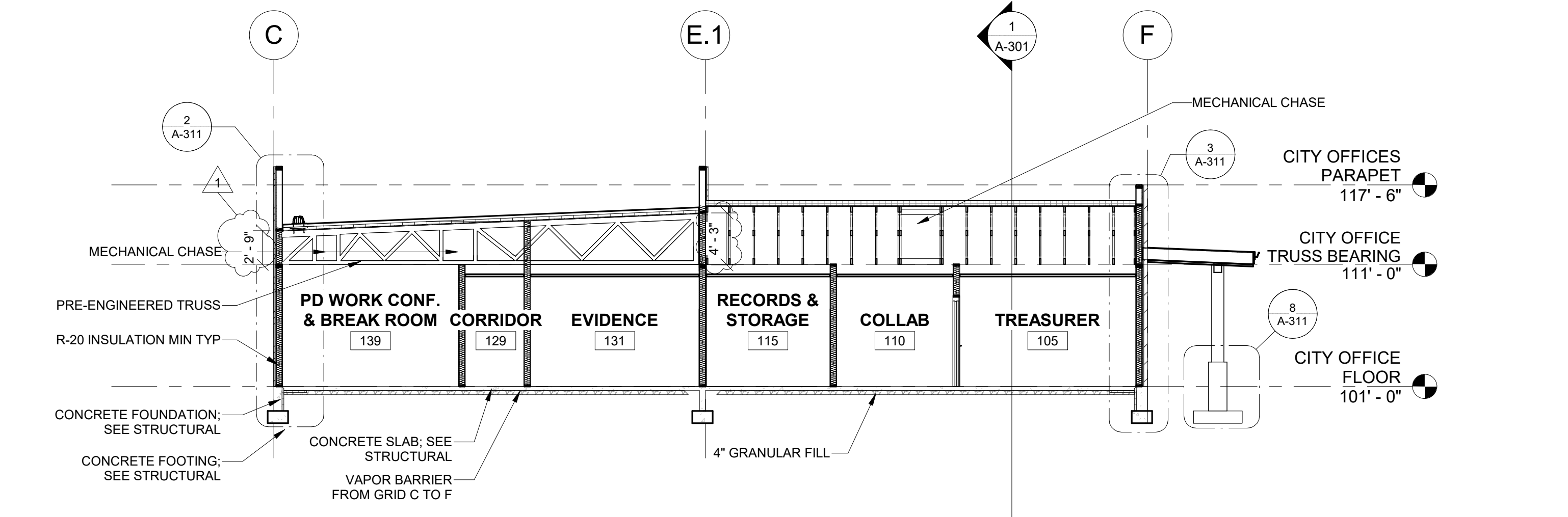

2 NORTH/SOUTH SECTION 2  
1/8" = 1'-0"

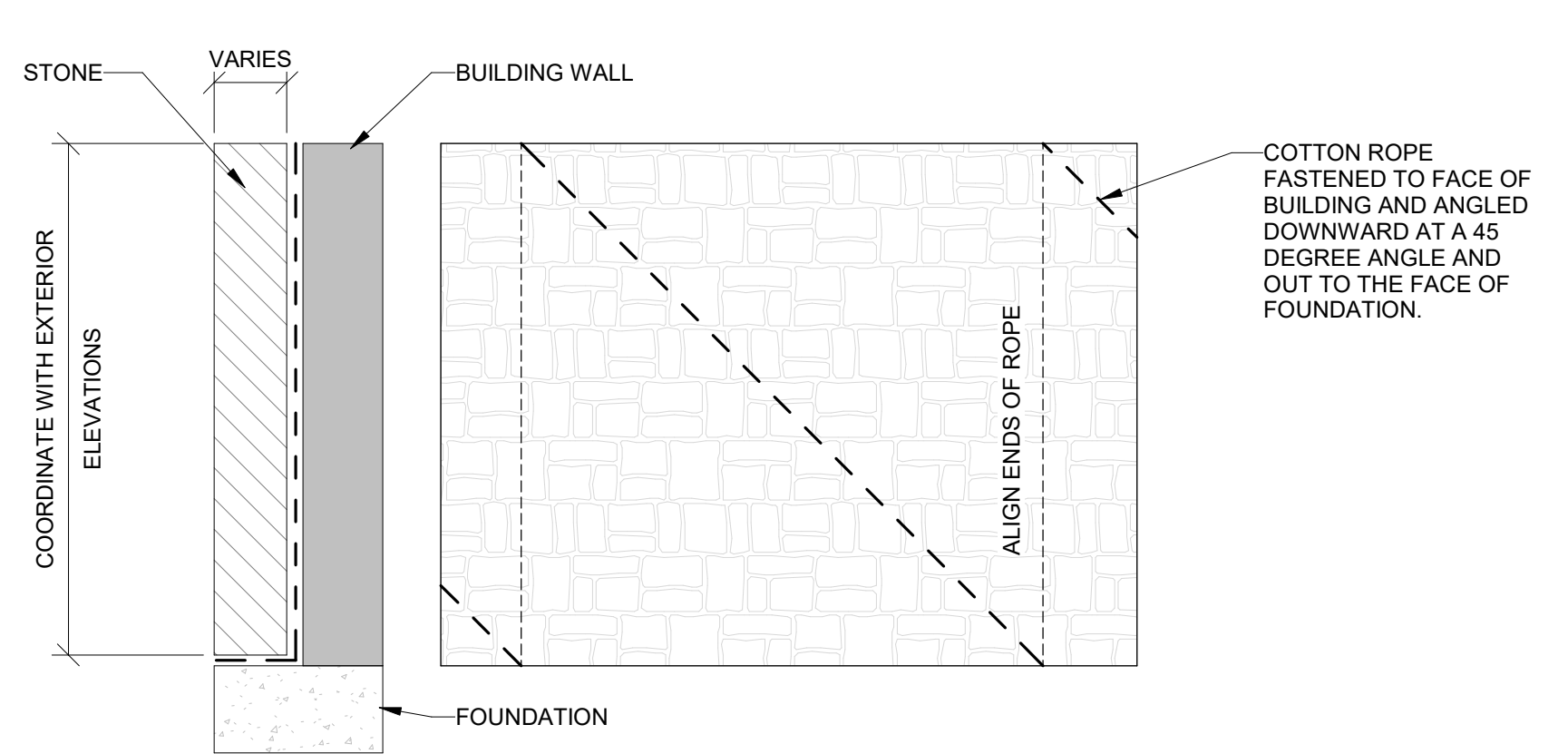

9 STONE WEEP DETAIL  
1" = 1'-0"

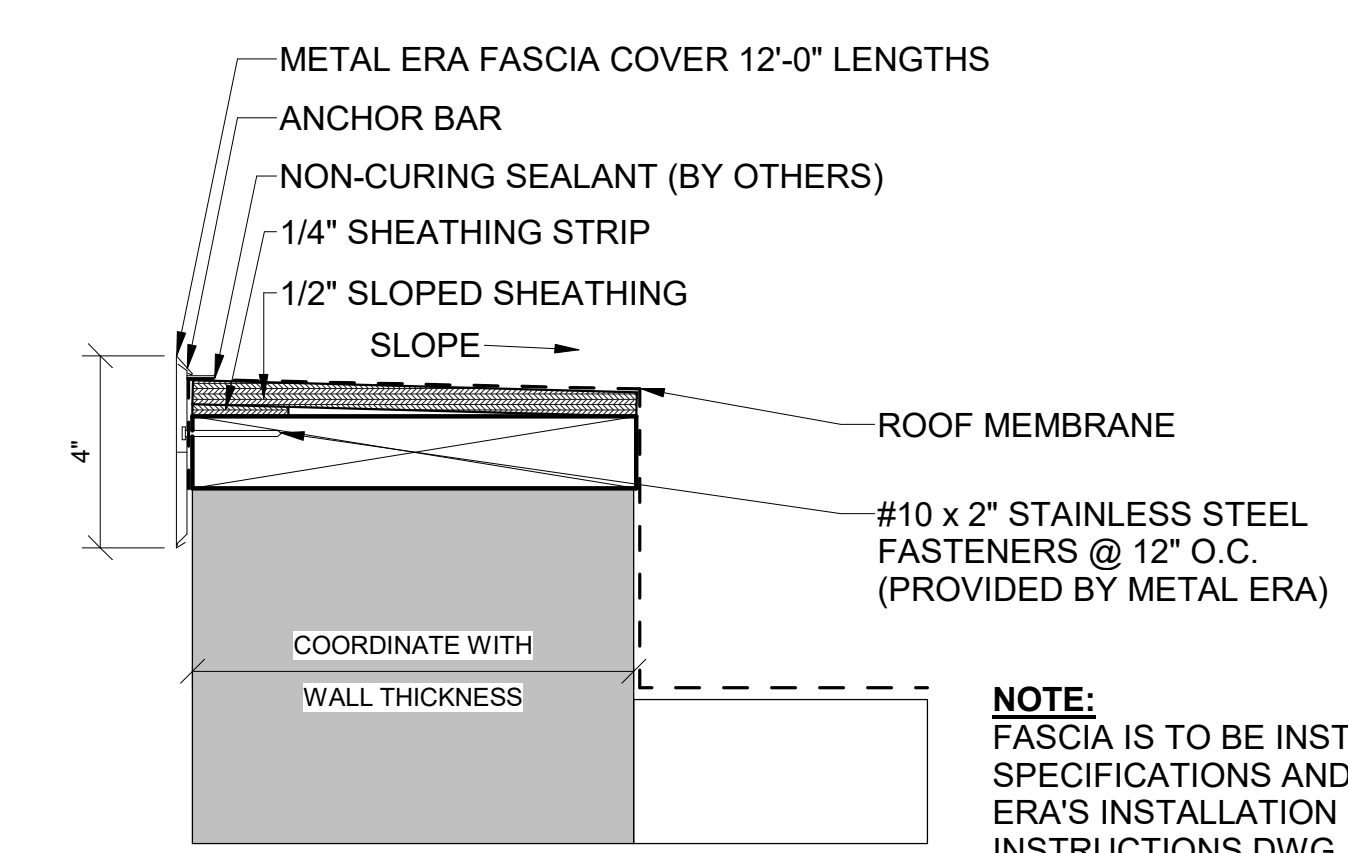

8 ES-1 PARAPET DETAIL  
3" = 1'-0"

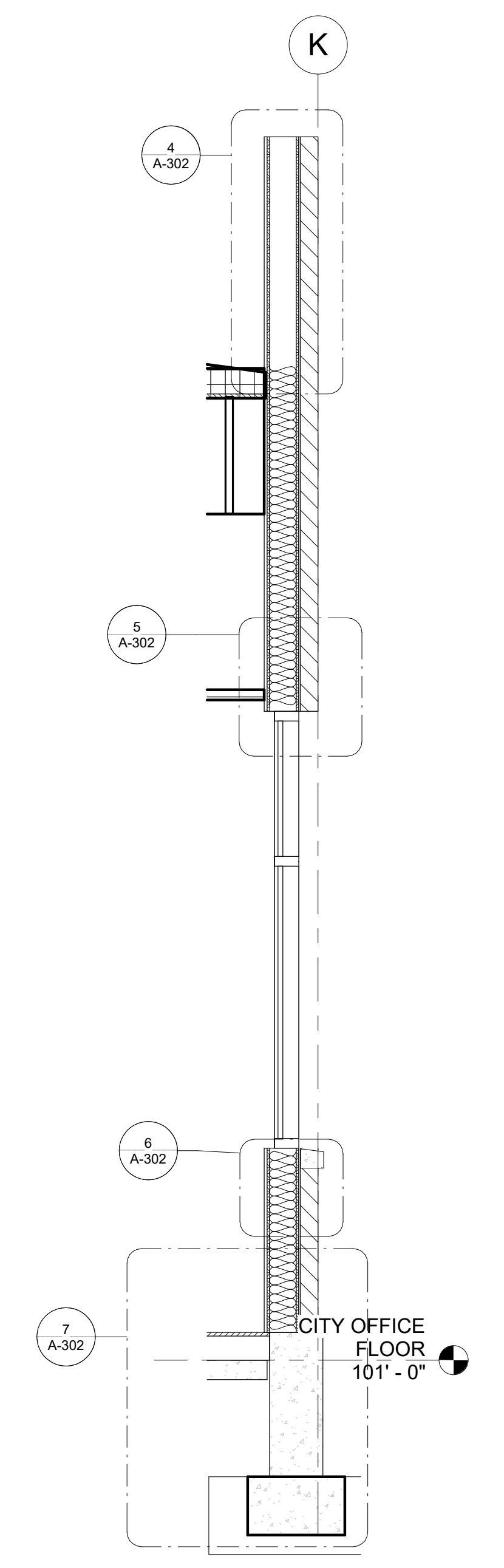

3 WALL SECTION  
1/2" = 1'-0"

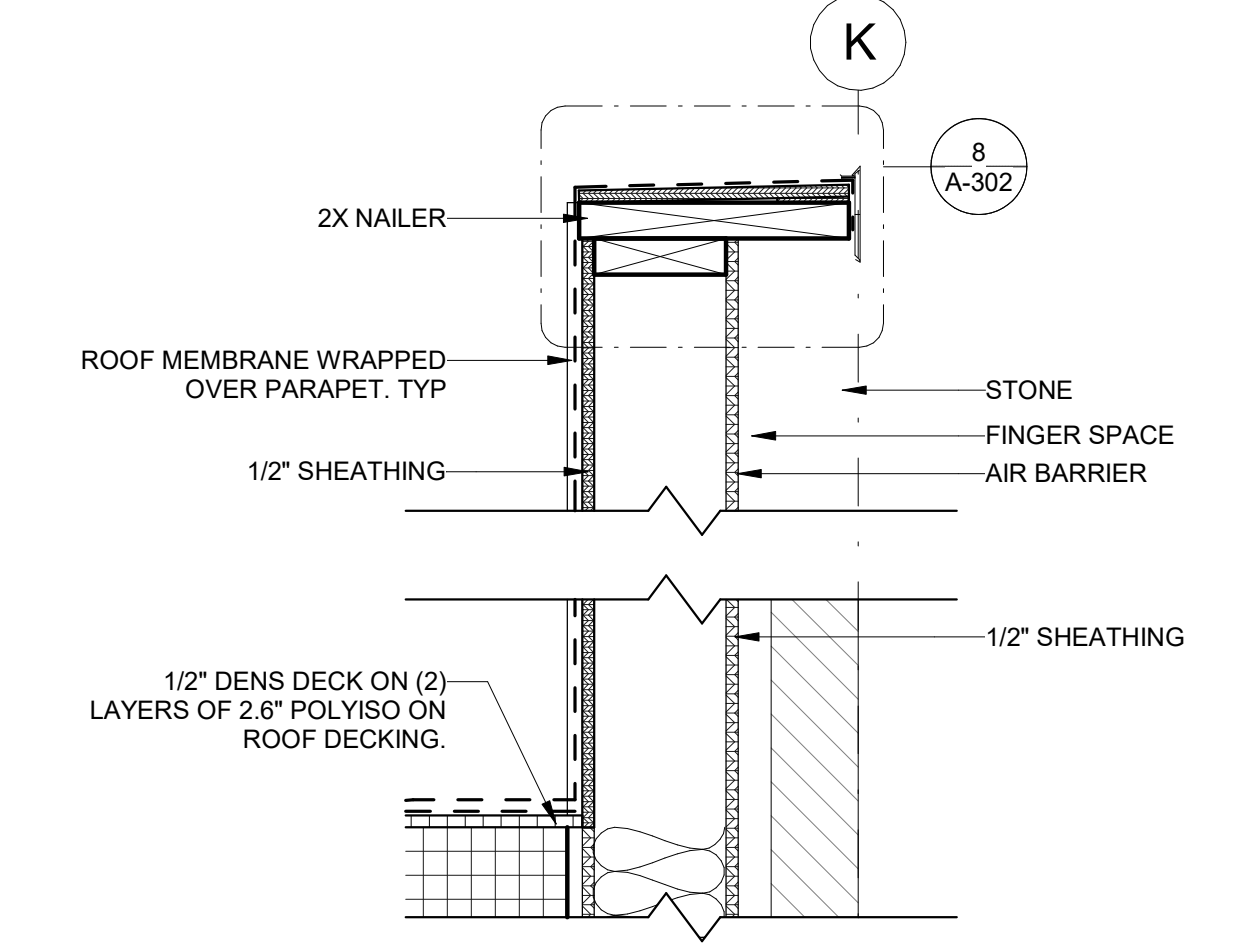

4 DETAIL  
1 1/2" = 1'-0"

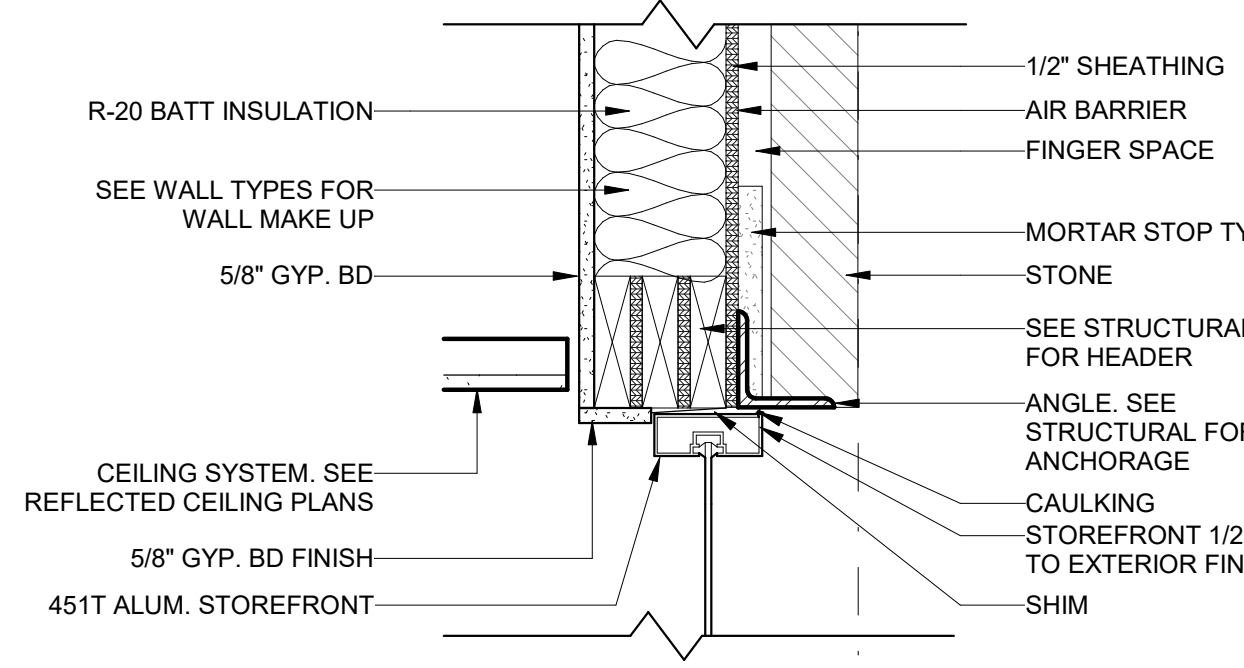

5 DETAIL  
1 1/2" = 1'-0"

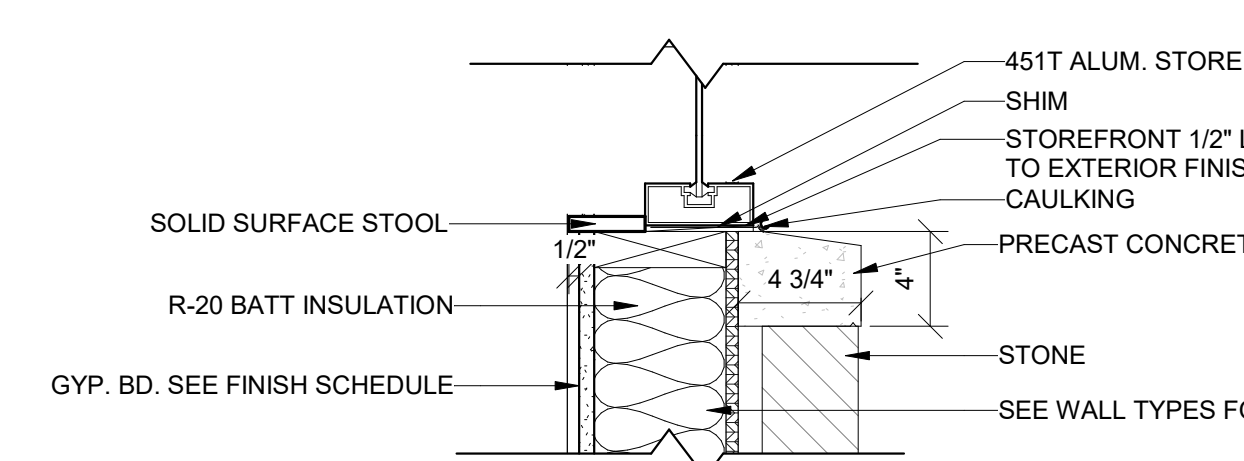

6 DETAIL  
1 1/2" = 1'-0"

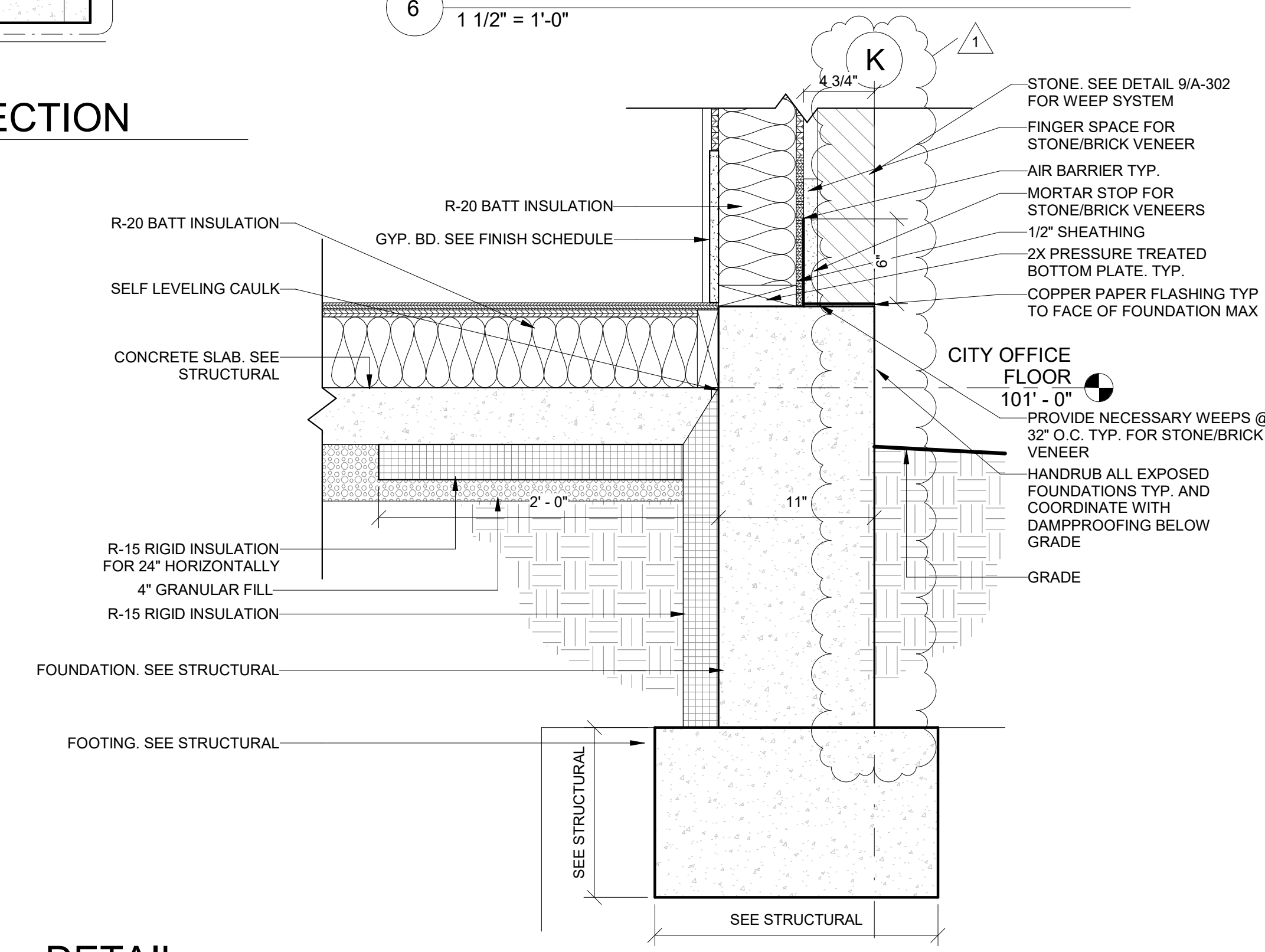

7 DETAIL  
1 1/2" = 1'-0"

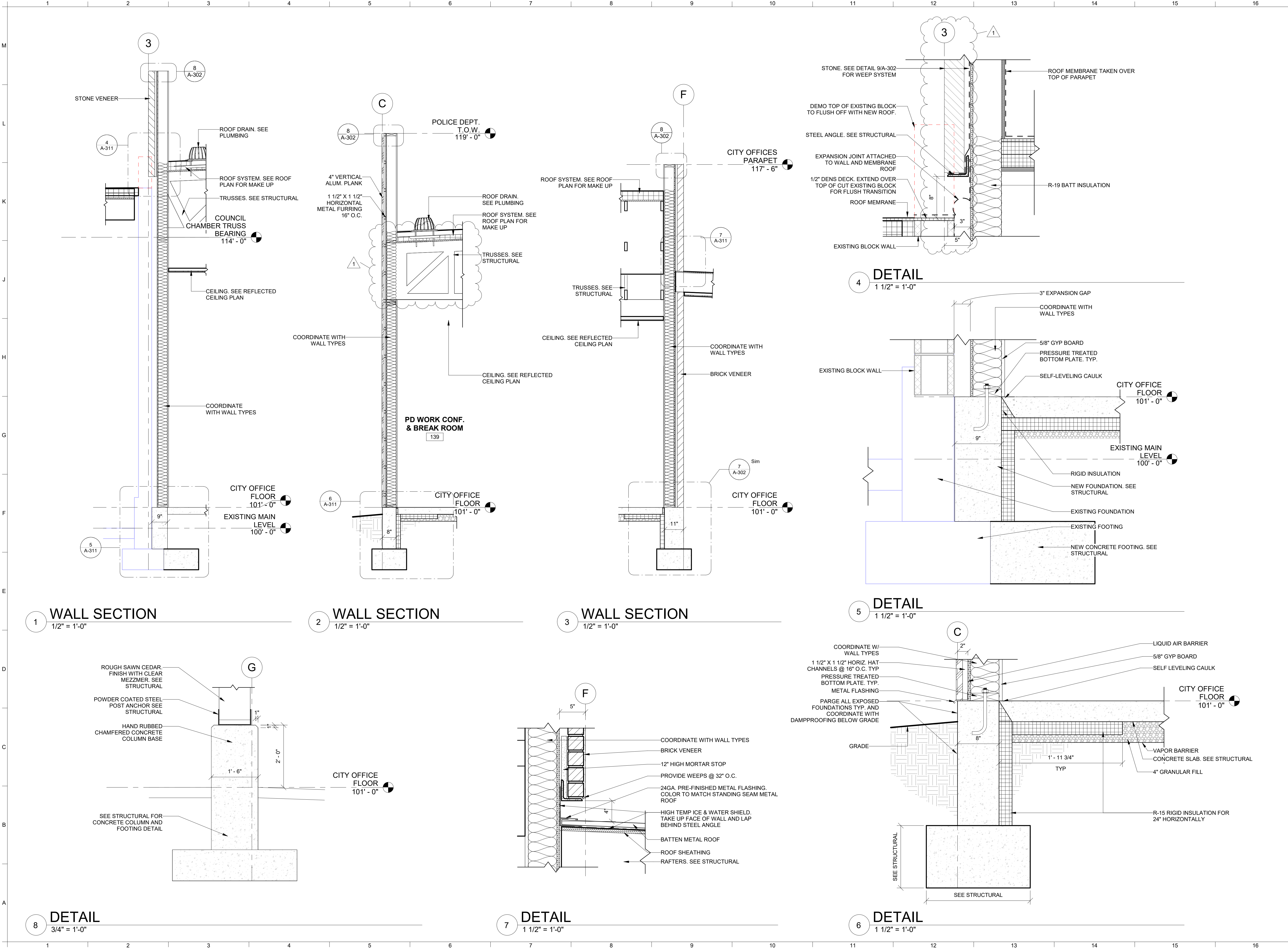

REVISIONS		
NO.	DATE	DESCRIPTION
1	05/22/2028	ADDENDUM NO.1

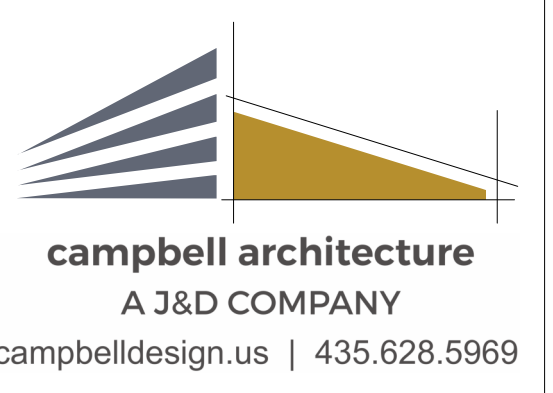
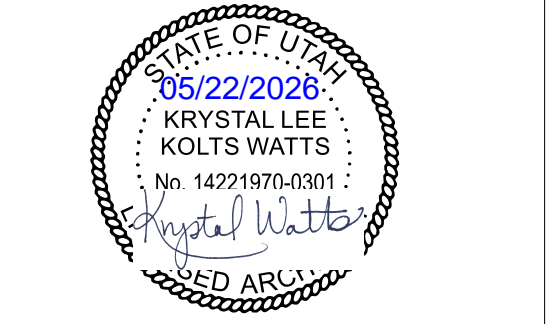

File Path: \\adsales\docs\2509-014 Wellington City Office\DWG\WELLINGTON CITY OFFICE.rvt  
Issue Date: 02/22/2028 1:50:19 PM

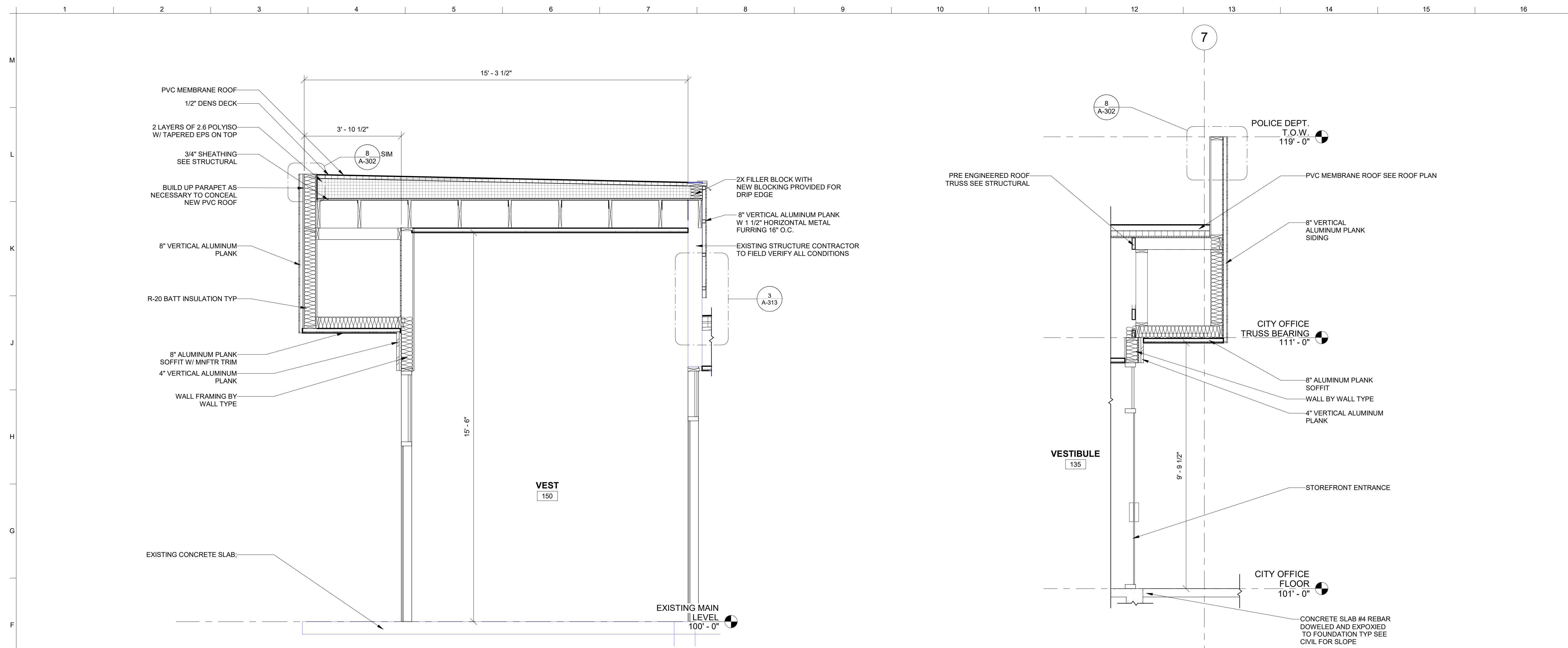

**1** EXISTING SOFFIT FD SECTION  
1/2" = 1'-0"

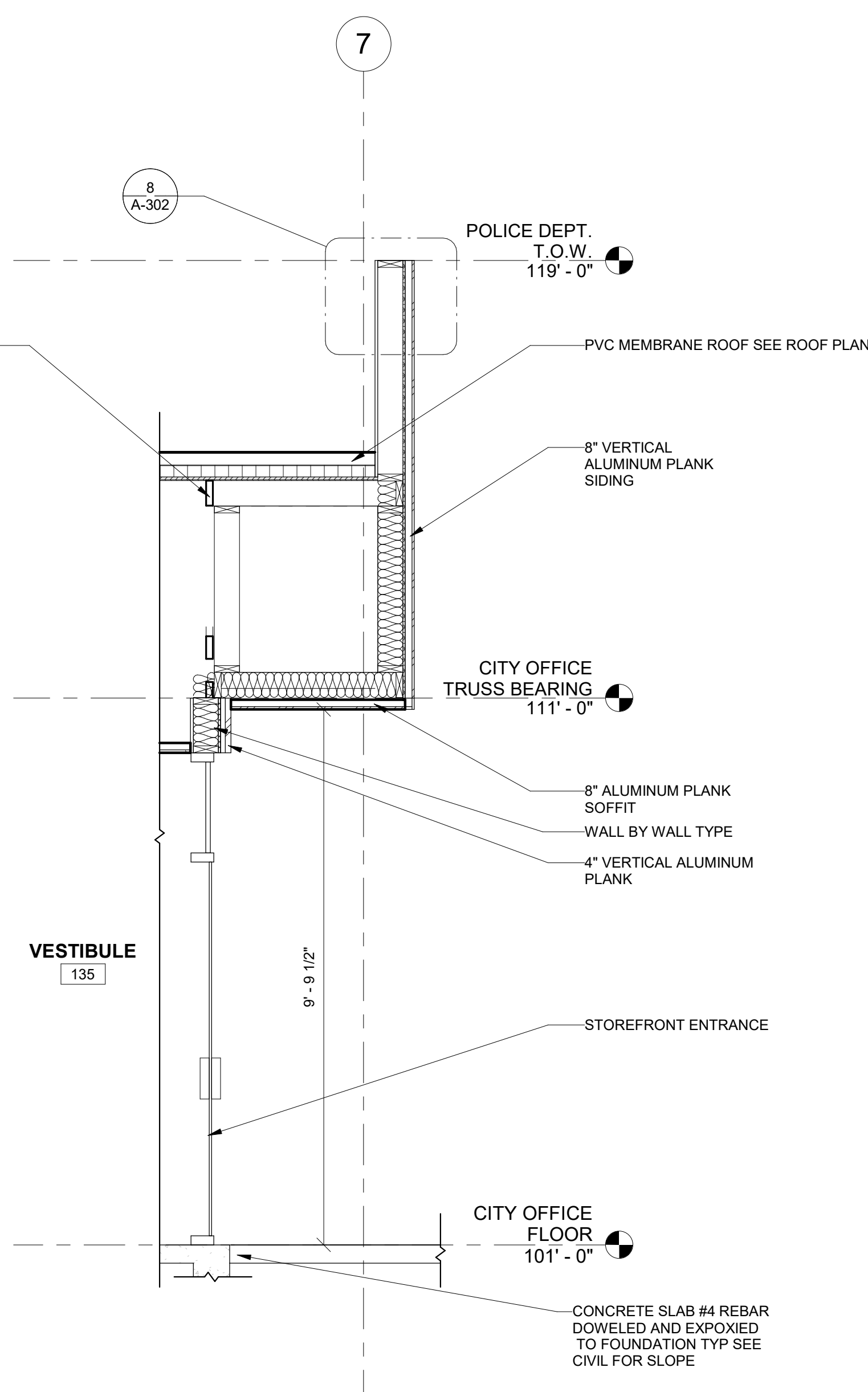

**2** SECTION  
1/2" = 1'-0"

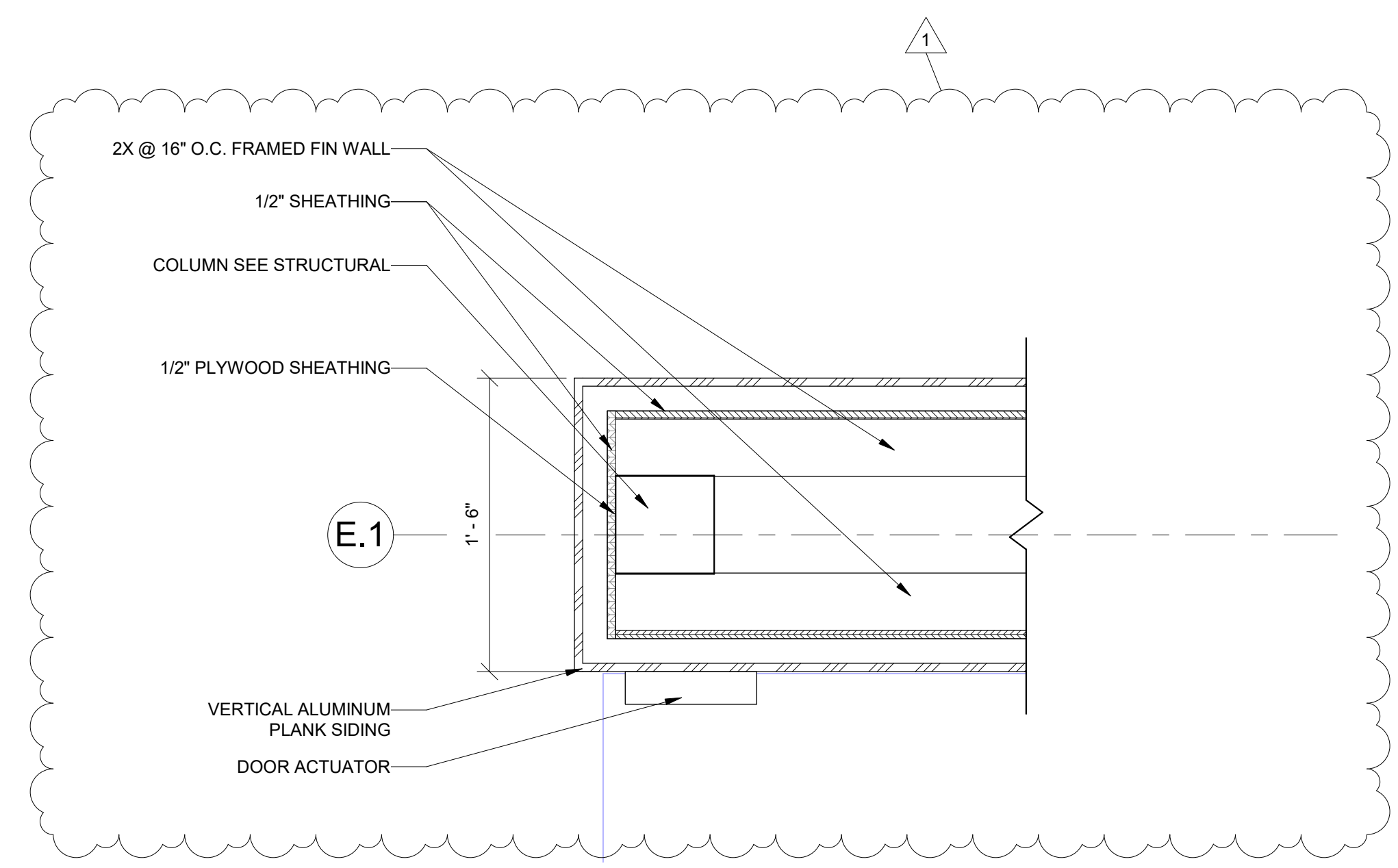

**4** FD COLUMN DETAIL  
1 1/2" = 1'-0"

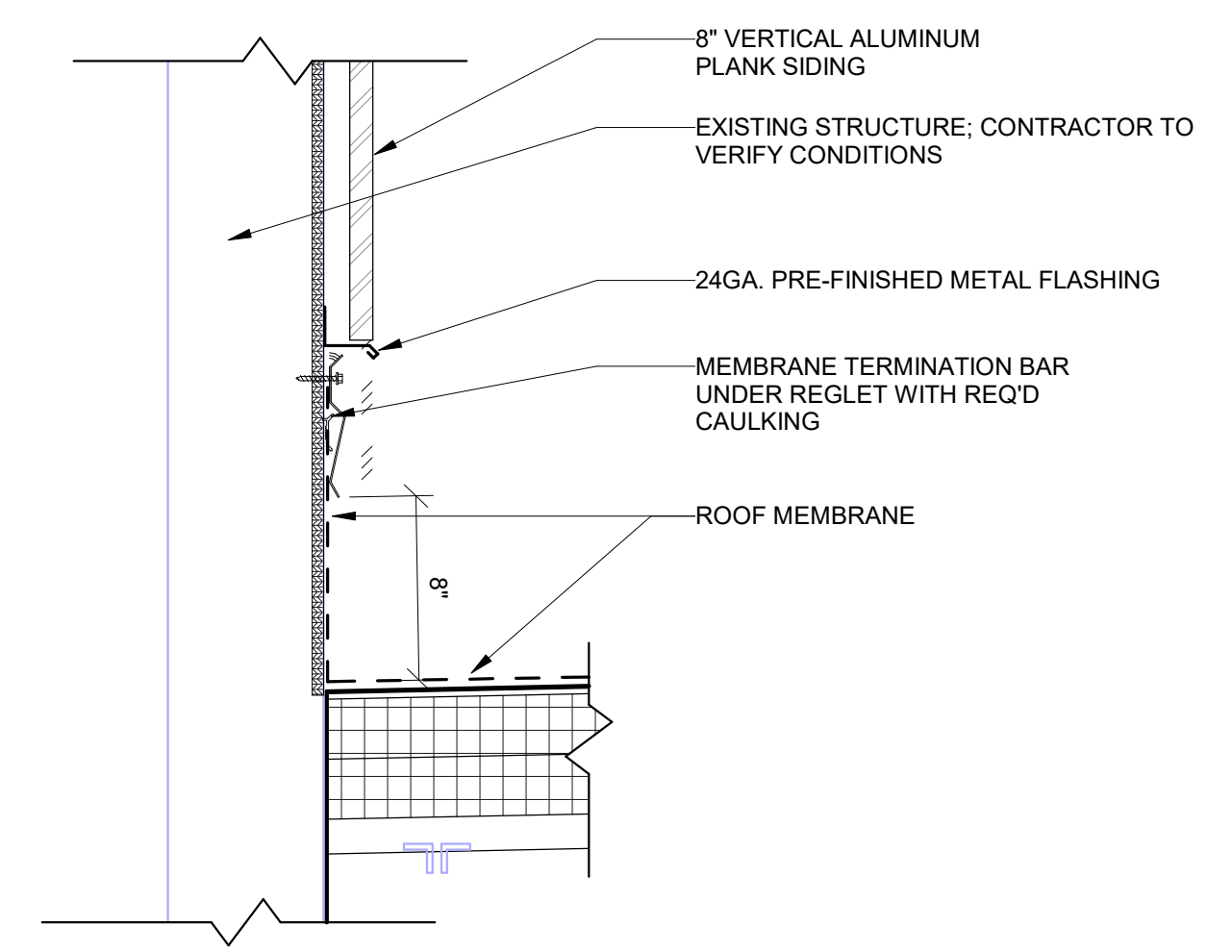

**3** FD SOFFIT TERMINATION BAR  
1 1/2" = 1'-0"

NO.	DATE	DESCRIPTION
1	05/22/28	ADDENDUM NO.1

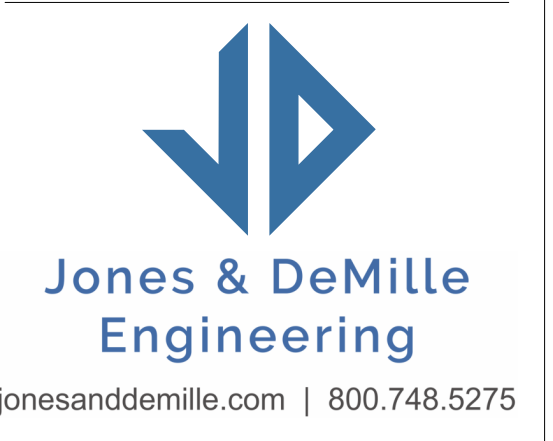
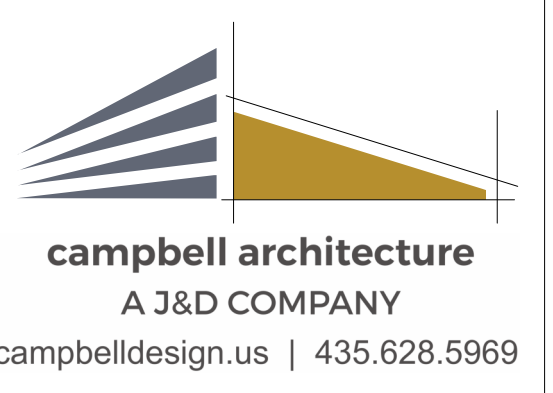
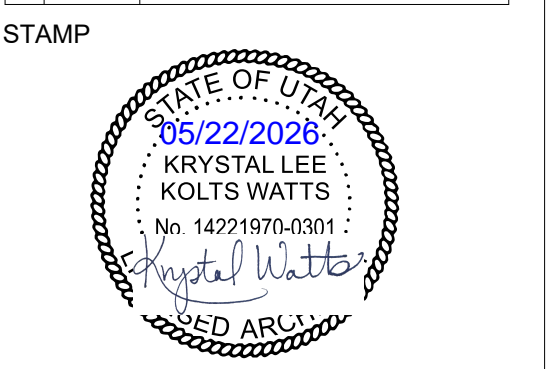

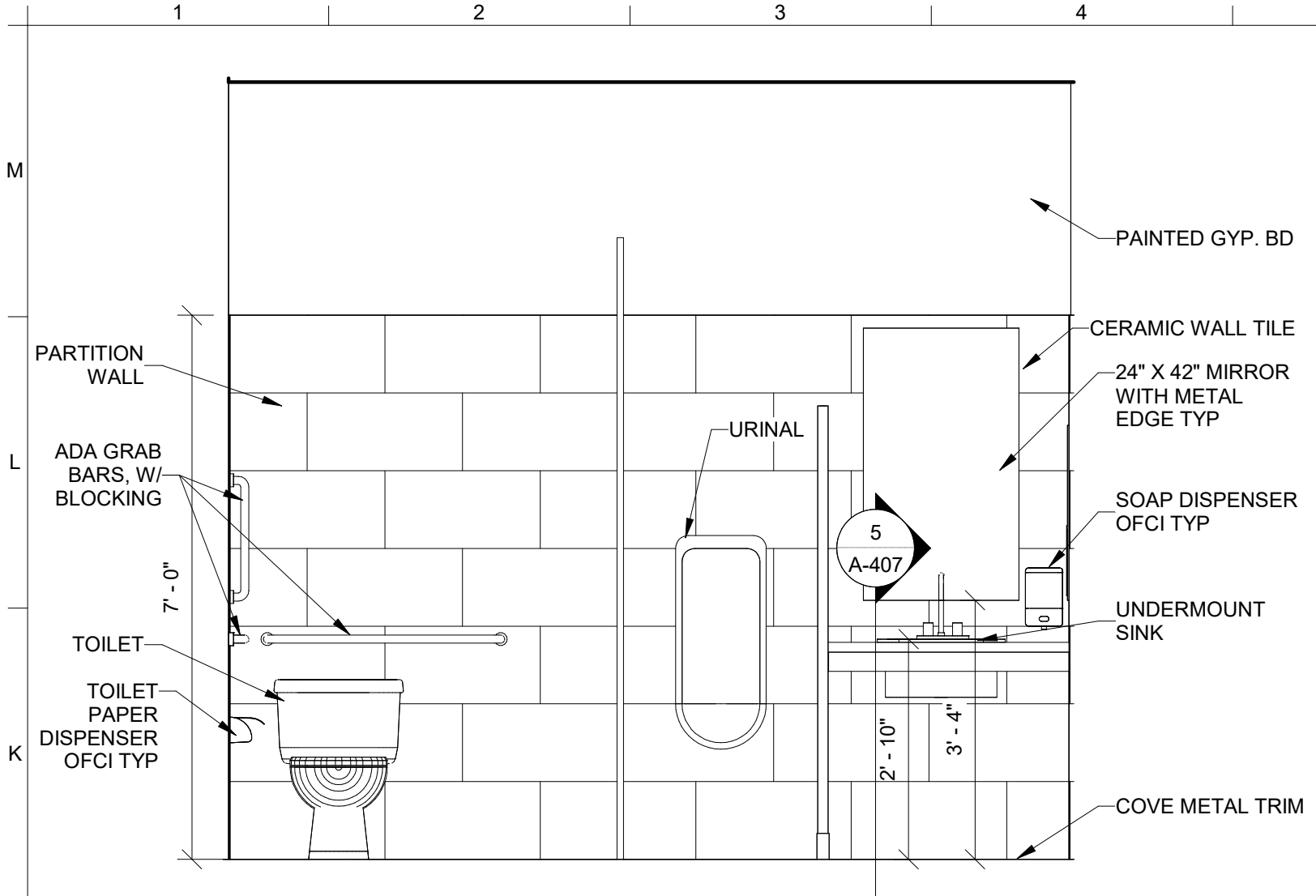

1 MENS RESTROOM 120  
 1/2" = 1'-0"

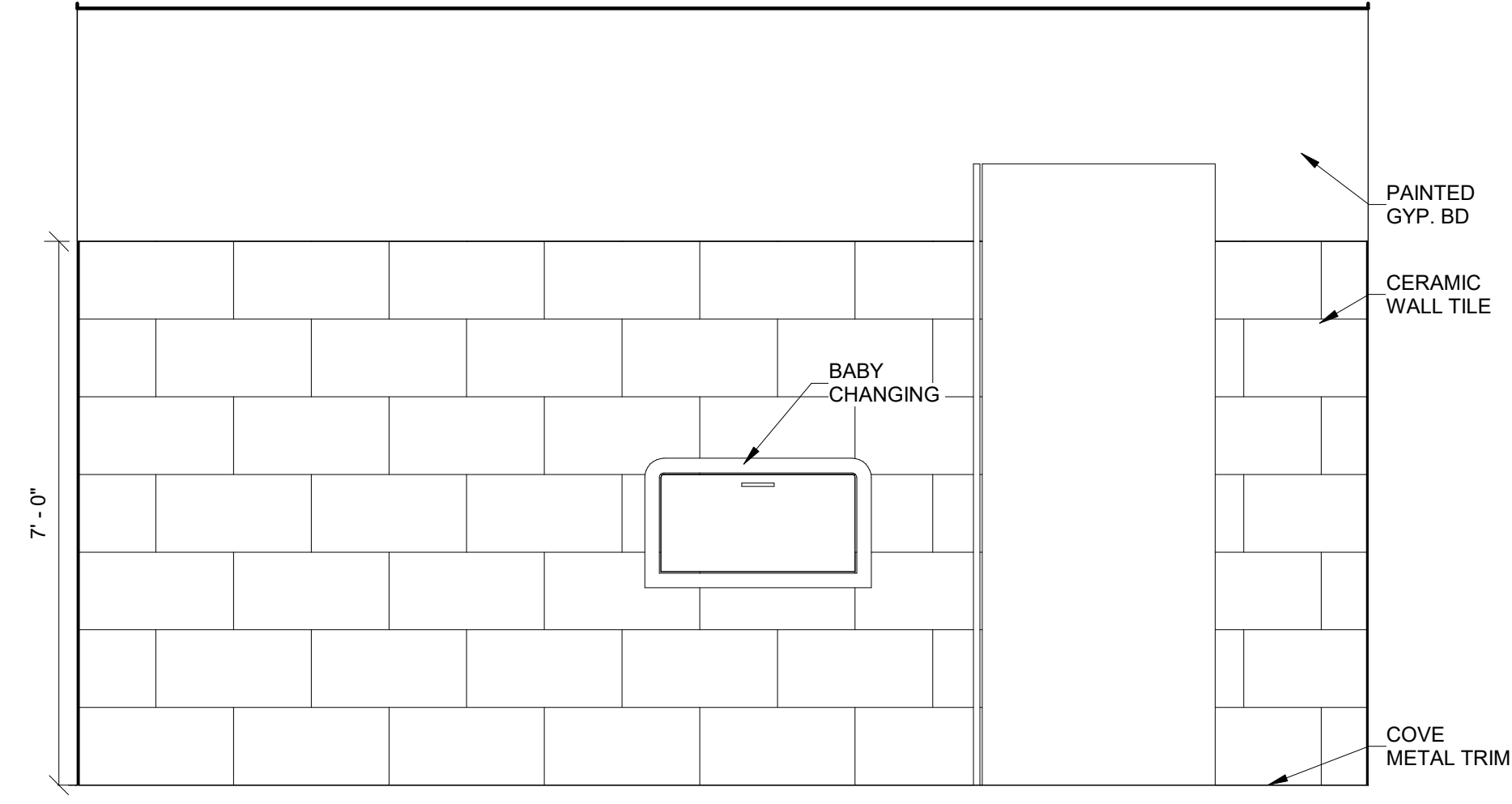

2 MENS RESTROOM 120  
 1/2" = 1'-0"

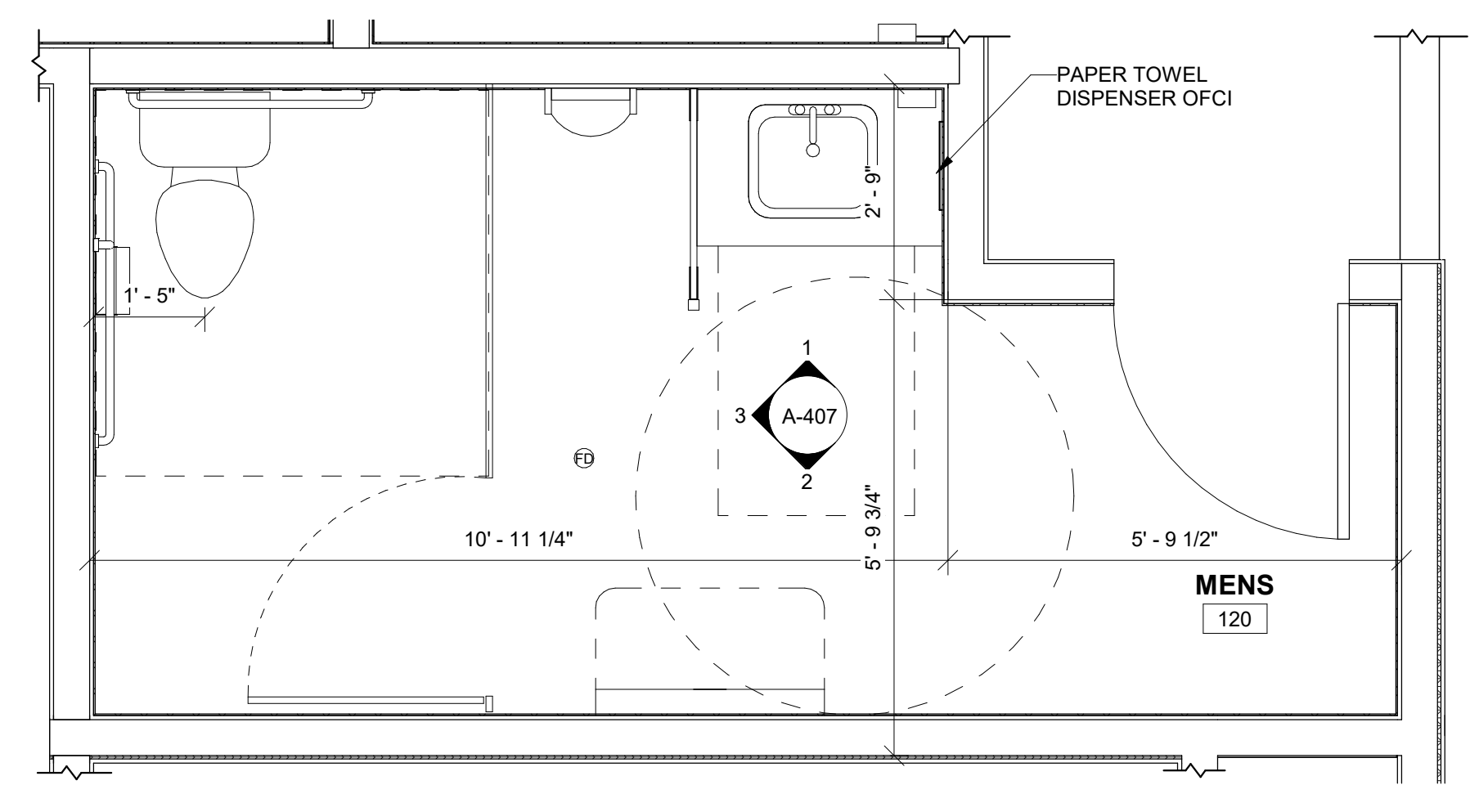

A ENLARGED PLANS MENS 120  
 1/2" = 1'-0"

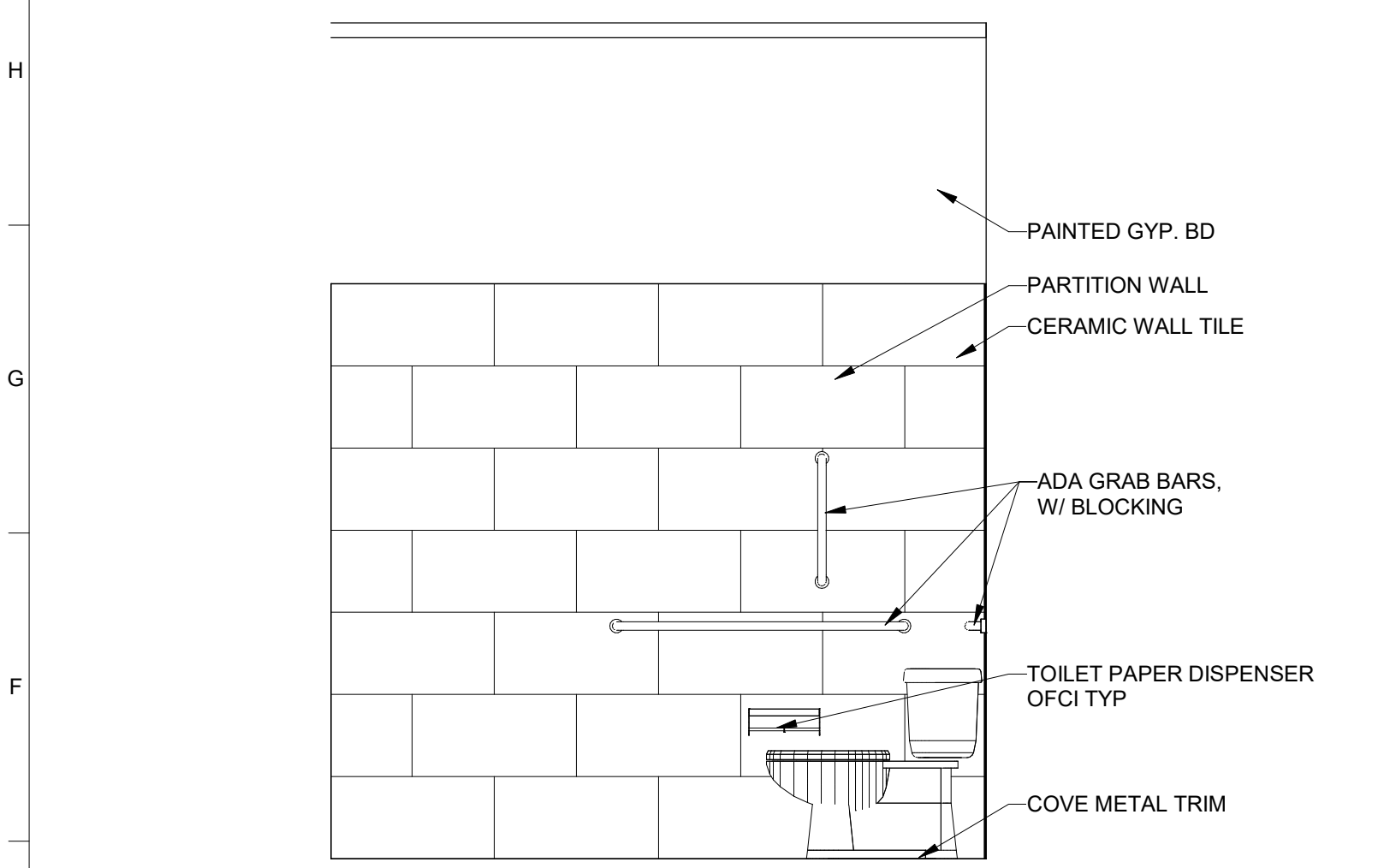

3 MENS RESTROOM 120  
 1/2" = 1'-0"

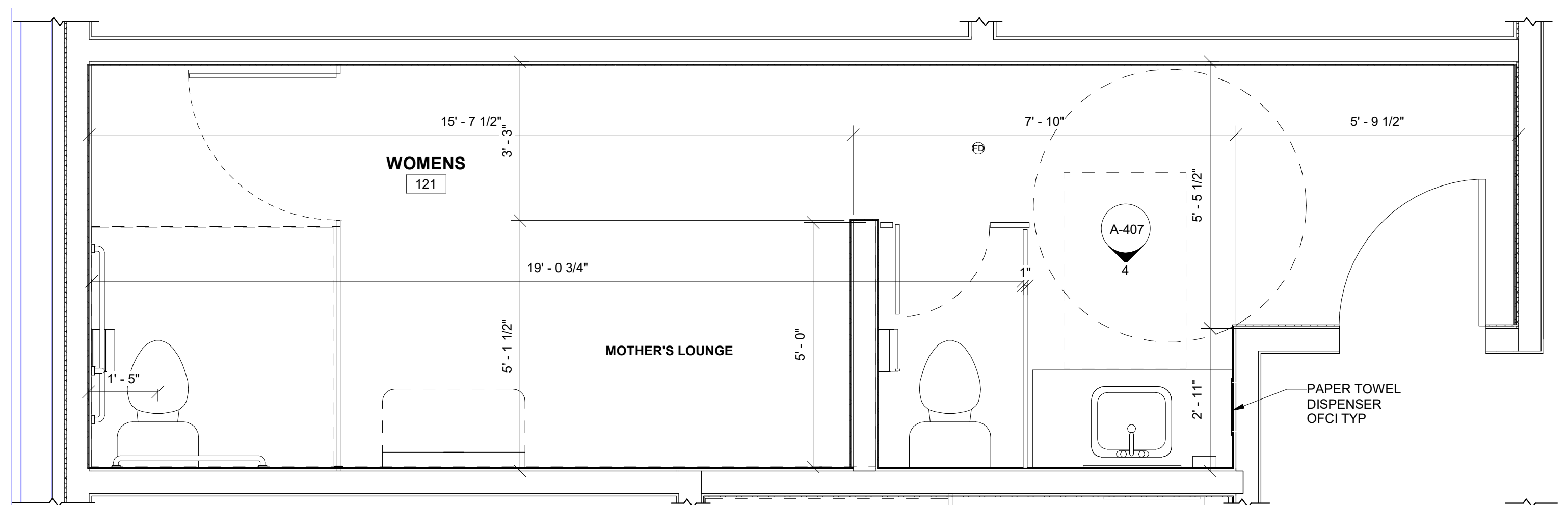

B ENLARGED PLANS CO WOMENS 121  
 1/2" = 1'-0"

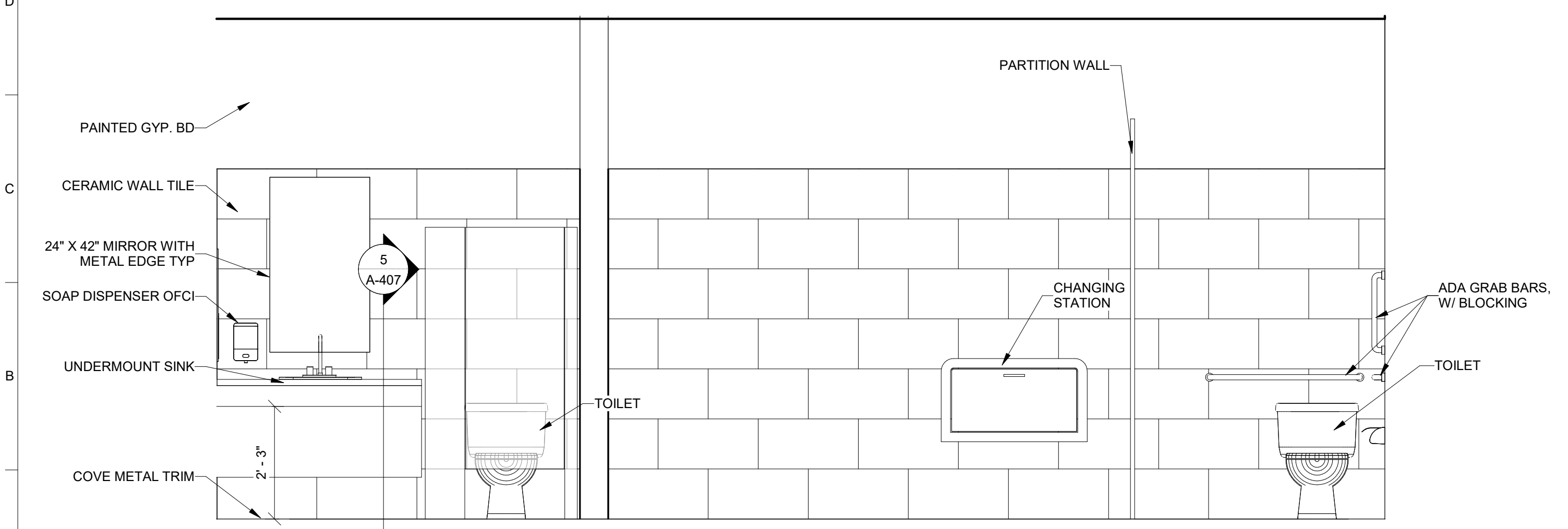

4 WOMENS RESTROOM 121  
 1/2" = 1'-0"

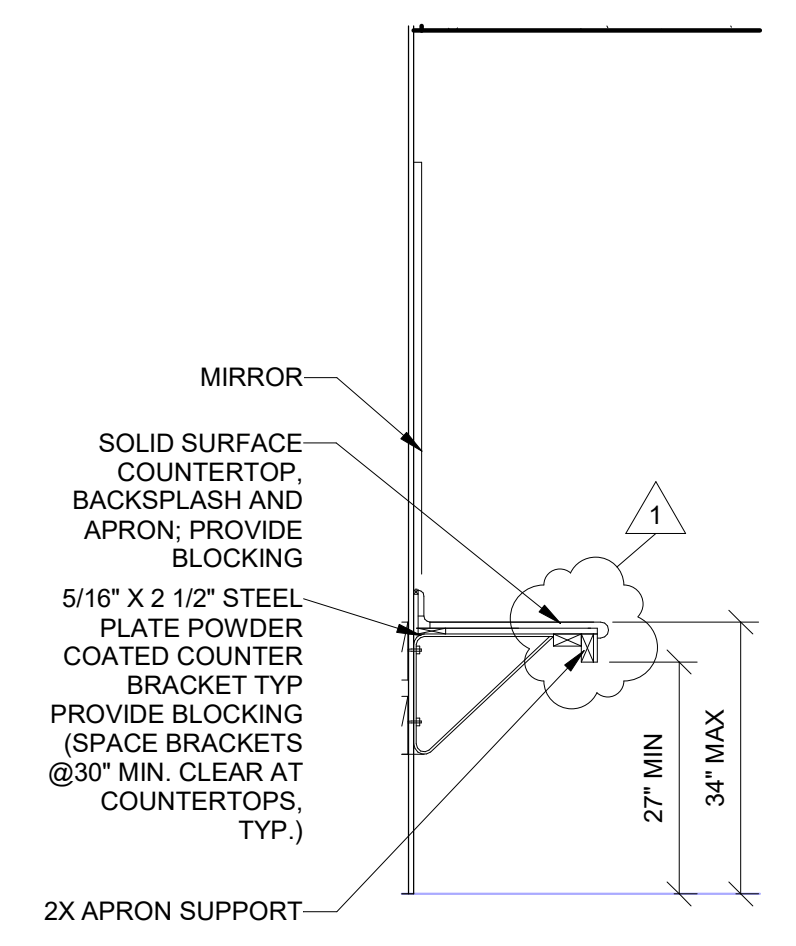

5 COUNTER SECTION  
 1/2" = 1'-0"

REVISIONS

NO.	DATE	DESCRIPTION
1	05/22/2028	ADDENDUM NO.1

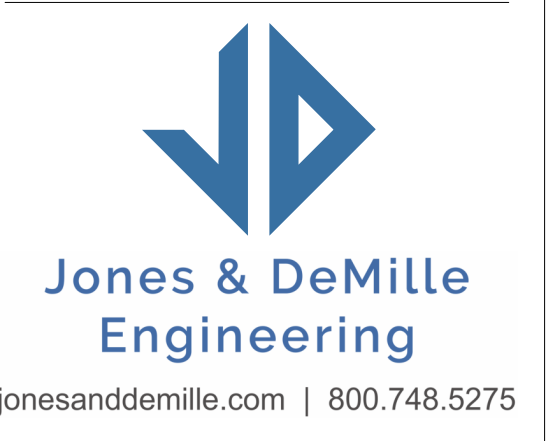
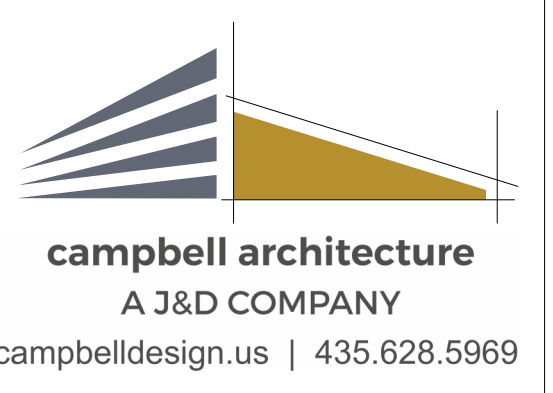
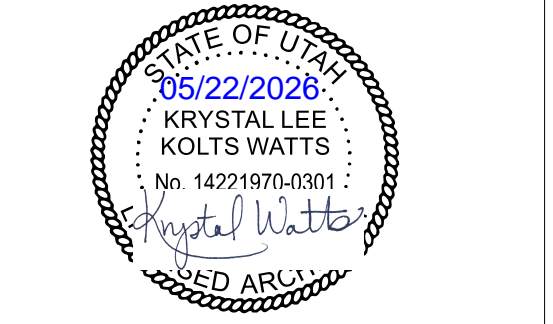

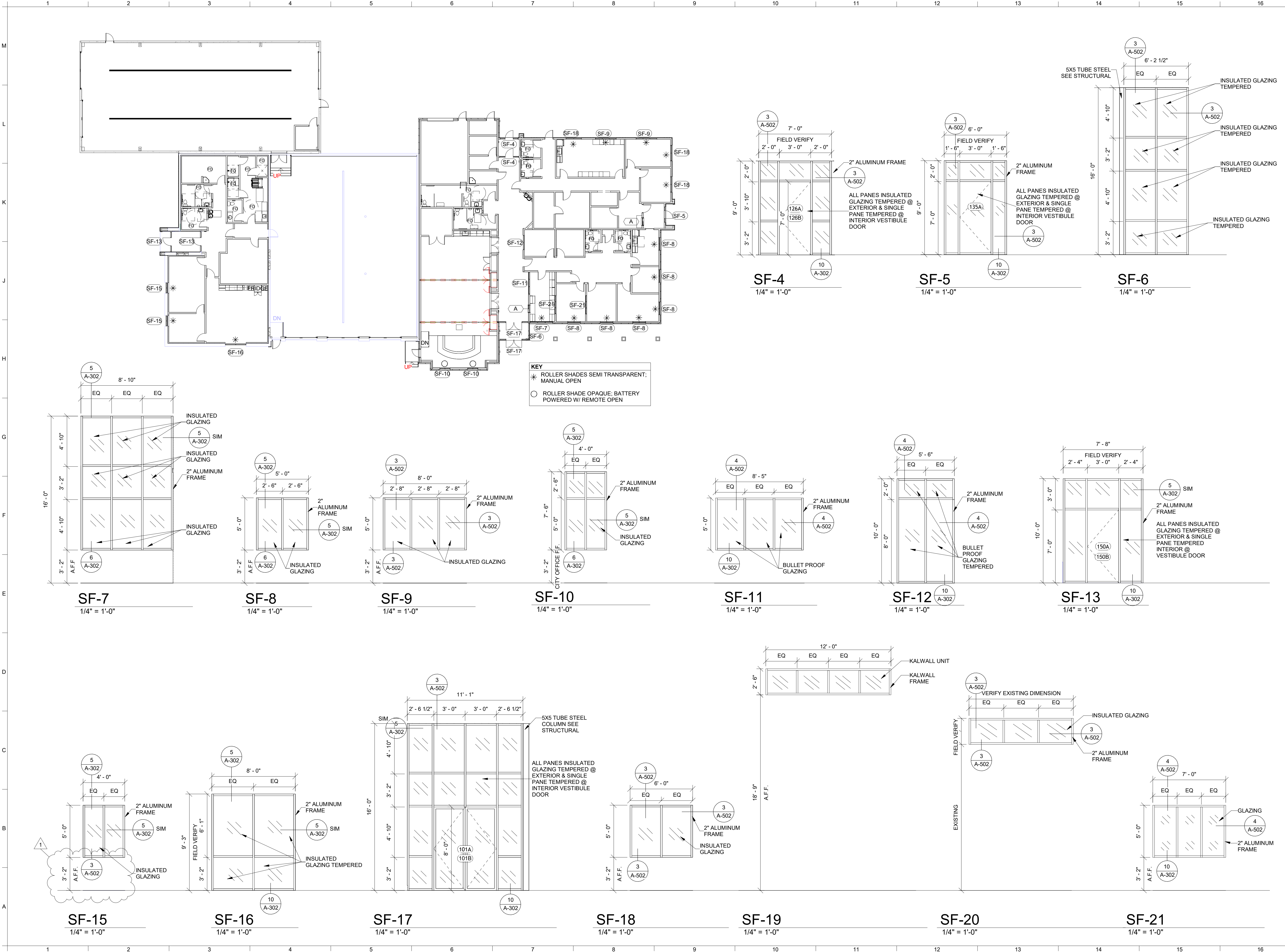

**KEY**  
 \* ROLLER SHADES SEMI TRANSPARENT; MANUAL OPEN  
 ○ ROLLER SHADE OPAQUE; BATTERY POWERED W/ REMOTE OPEN

NO.	DATE	DESCRIPTION
1	05/22/20	ADDENDUM NO.1

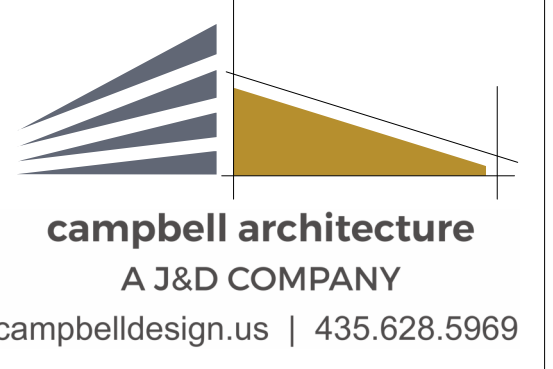
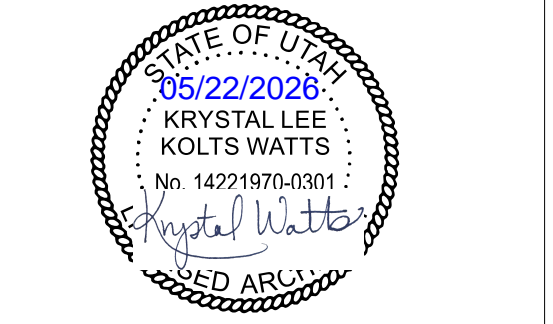

File Path: \\ussd01\cadd\2509-014 Wellington City Office\2509-014 Wellington City Office.rvt Issue Date: 02/22/2020 1:50:29 PM